

Owner's Manual

Arteon, CC

Edition 06/2022

United States version

Teil-Nr.: 3G8012723SM

Print status: 01.03.2022

English USA: 2022_06

V1, R1, USA, en_US

Vehicle-specific information can be entered below:

Vehicle Identification Number (VIN)																

Vehicle information	
Engine output (kW)	
Engine code	
Transmission code	
Paint number	

Recommended engine oil	
------------------------	--

PR number	Vehicle service type

Notes

Delivery inspection was performed on:	Date of delivery/first approval (whichever occurs first):
Volkswagen dealer stamp	Volkswagen dealer stamp



WARNING

Operating, servicing and maintaining a passenger vehicle or off-highway motor vehicle can expose you to chemicals including engine exhaust, carbon monoxide, phthalates, and lead, which are known to the State of California to cause cancer and birth defects or other reproductive harm. To minimize exposure, avoid breathing exhaust, do not idle the engine except as necessary, service your vehicle in a well-ventilated area and wear gloves or wash your hands frequently when servicing your vehicle. For more information go to www.P65Warnings.ca.gov/passenger-vehicle.

BTT-1671

Fig. 1

Volkswagen AG works constantly to improve all of its products. Due to ongoing vehicle development, changes in design, equipment, and technology are possible at any time. The information regarding equipment, appearance, performance, dimensions, weights, fuel consumption, standards, and functions of the vehicle is the information that was available at the time of the editorial deadline for this manual. Some of the equipment and functions may not be available until later or may be available only in certain countries. Contact your local authorized Volkswagen dealer or authorized Volkswagen Service Facility for more information.

The vehicle shown may be equipped with optional equipment for an additional price and is only offered in certain markets. An authorized Volkswagen dealer can inform you about differences in your particular country. Subject to change. No legal obligations or commitments may be derived from the information, illustrations, and descriptions in this manual.

No reprint, reproduction, or translation of this Manual is permitted, even in excerpts, without the express written consent of Volkswagen AG.

Volkswagen AG expressly reserves all rights under applicable copyright law. Subject to change.

© 2022 Volkswagen AG

We thank you for buying a Volkswagen vehicle

This Volkswagen vehicle is equipped with advanced technology incorporating a number of convenience features for you to enjoy in your daily driving.

Please carefully read and follow the information in this Owner's Manual. It will help you to become more familiar with your vehicle and to be able to recognize and avoid hazardous situations for you and others.

If you have questions about your vehicle or if you believe that the manual is not complete, please contact your authorized Volkswagen dealer or your authorized Volkswagen Service Facility. Authorized Volkswagen dealers and authorized Volkswagen Service Facilities always welcome your questions, suggestions, and constructive criticism.

We hope you enjoy driving your vehicle and we wish you safe and pleasant motoring.

WARNING

Please note the important safety information about using a child restraint system in the front passenger seat ⇒  [Introduction](#)

About this Owner's Manual

This Owner's Manual is valid for all models and versions of your Volkswagen model and model year. The Owner's Manual describes all equipment and models without indicating special equipment or model versions. This may include descriptions of equipment that your vehicle may not have or that may only be available in some countries. You can find details of your actual vehicle equipment in your sales documentation or by contacting an authorized Volkswagen dealer or authorized Volkswagen Service Facility. Volkswagen recommends contacting an authorized Volkswagen dealer or authorized Volkswagen Service Facility.

This Owner's Manual describes a passenger vehicle.

All information in this Owner's Manual was correct at the time of printing. Due to continuous vehicle development, there may be differences between your vehicle and the information in this Owner's Manual. No legal commitment can be derived from the information, illustrations, or descriptions in this manual.

Brief definitions are placed in front of some sections in a different color to summarize the topic in question. Detailed information about the systems and equipment along with their properties, conditions, and system limitations is included in the associated sections.

Due to legal and technical requirements, the vehicle may be provided with different Owner's Manual variants depending on the country.

Printed Owner's Manual

The printed Owner's Manual describes the range of functions of the vehicle at the time of release. Additions and amendments to the Owner's Manual may also be added in the form of supplements.

An alphabetically ordered keyword index as well as a list of abbreviations that explains technical abbreviations and designations are included to assist with orientation and understanding of the printed manual.

 **Make sure that the printed documents are in the vehicle if you wish to sell or lend the car. Volkswagen also recommends resetting the Infotainment system to its factory settings in order to delete all personal data.**

Explanations

The following section explains phrasings and terms found in the Owner's Manual to help understanding.

Directions

Directions (left, right, front, back) are in reference to the driving direction unless noted otherwise.

Units and speeds

The display in miles instead of kilometers or mph instead of km/h is determined by the versions of the instrument cluster and Infotainment system that are installed, which varies depending on the country where the vehicle is sold.

Illustrations

Illustrations are only for orientation and are simply used to provide a visual display of descriptions and instructions. The illustrations may differ from your vehicle.

This Owner's Manual was created for left-hand drive vehicles. For *vehicles with right-hand drive steering*, controls are sometimes arranged differently from what is shown in the illustrations or described in the text.

Form of address

To improve readability, plural pronouns are used here to refer to a singular subject of any gender. This applies to all genders equally. The use of abbreviations are for editorial purposes and do not contain any evaluation.

Terms used and their meanings:

Sunroof The term "power sunroof" is used as a synonym for all variants of the tilting and sliding panoramic sunroof depending on the vehicle equipment.









Authorized Volkswagen dealer or authorized Volkswagen Service Facility Authorized Volkswagen dealer or authorized Volkswagen Service Facility refers to workshops with instructed or trained personnel that specialize in servicing passenger vehicles. A qualified professional can be an authorized Volkswagen dealer or authorized Volkswagen Service Facility or an independent workshop.

Authorized Volkswagen dealer or authorized Volkswagen Service Facility Authorized Volkswagen dealer or authorized Volkswagen Service Facility refers to workshops that have a contractual relationship with Volkswagen. This contractual relationship means that they have access to more information as well as a direct line of communication to the manufacturer.

Contact an authorized Volkswagen dealer or authorized Volkswagen Service Facility In some situations, it is necessary for you to drive your vehicle to an authorized Volkswagen dealer or authorized Volkswagen Service Facility so that it can be checked.

Contact an authorized Volkswagen dealer or authorized Volkswagen Service Facility for assistance If it is no longer possible to continue driving your vehicle, it is necessary to have it checked directly where it is by a professional. A decision regarding whether the vehicle can continue to be driven following inspection or whether it needs to be towed must then be made depending on the circumstances.

Explanation of symbols

	Indicates a reference to a section within a chapter containing important information and safety warnings  that should always be heeded.
	The arrow indicates the end of a section.
	This symbol indicates situations where the vehicle must be stopped as quickly as possible.
TM	The symbol means "Trademark" and indicates a recognized but not (yet) officially registered trademark. However, the absence of this symbol does not constitute a waiver of any rights associated with intellectual property.
	This symbol indicates a registered trademark. However, the absence of this symbol does not constitute a waiver of any rights associated with intellectual property.
	Symbols of this type refer to warnings in the same section or on the specified page, pointing out possible risks that can cause accidents and personal injuries and how to help prevent them.
	
	
	Cross-reference to a warning of potential property damage, in the same section or on the specified page.

DANGER

DANGER indicates a hazardous situation which, if not avoided, will result in death or serious injury.

WARNING

WARNING indicates a hazardous situation which, if not avoided, could result in death or serious injury.

CAUTION

CAUTION indicates a hazardous situation which, if not avoided, could result in minor or moderate injury.

NOTICE

NOTICE is used to address practices not related to physical injury, but related to damage to the vehicle.

 Texts with this symbol contain information about the environment and how you can help to protect it.

 Texts with this symbol contain supplementary information.

Vehicle overviews

View from the front

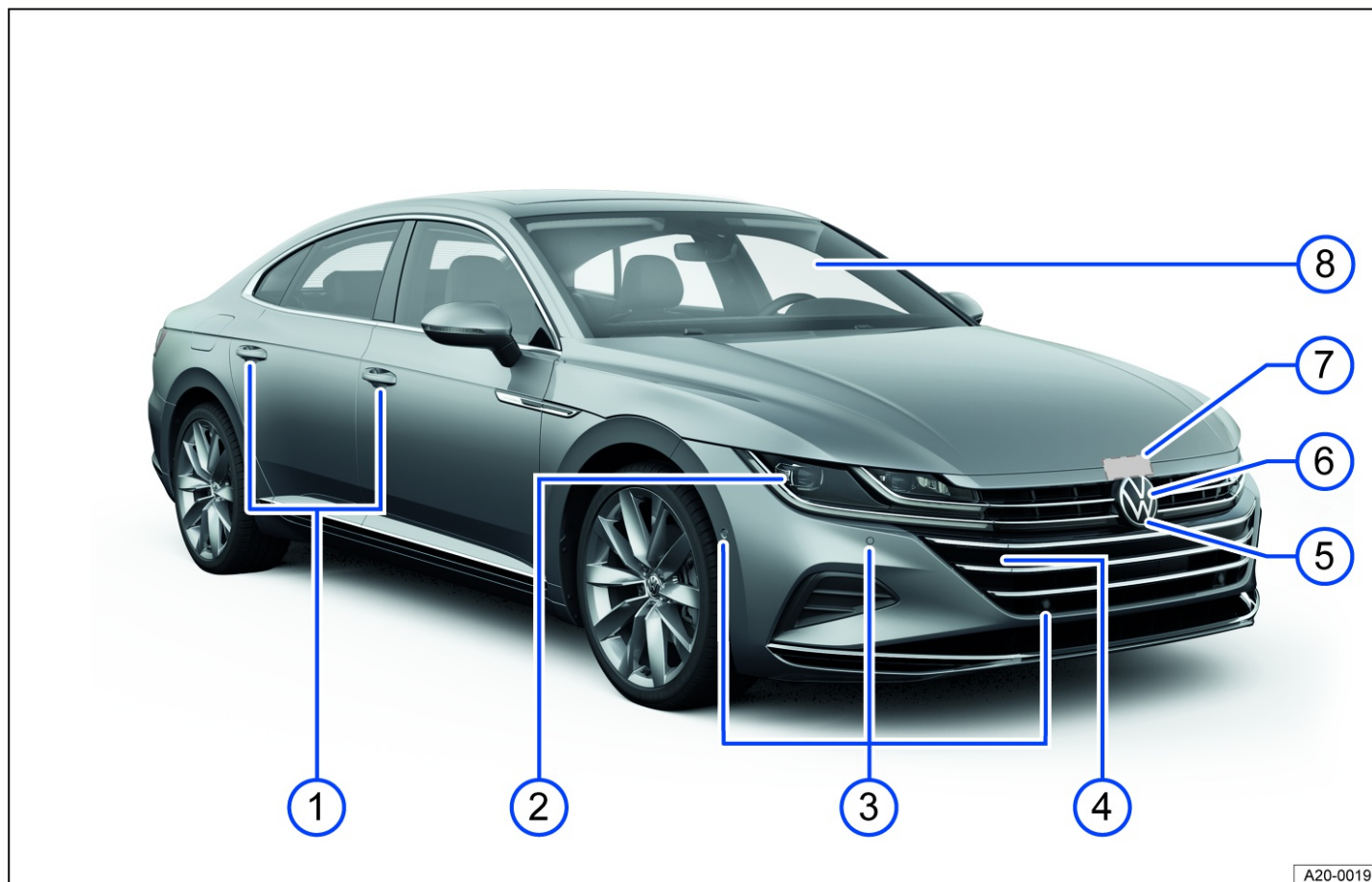

A20-0019

Fig. 2 Overview of vehicle from the front.

- ① Door handles ⇒ *Doors and central locking button*
- ② Headlights ⇒ *Exterior lighting*
- ③ Sensors for assistance systems ⇒ *Exterior care and cleaning*
- ④ Behind a cover: mount for towing eye ⇒ *Towing*
- ⑤ Camera for Area View ⇒ *Area View, ⇒ Exterior care and cleaning*
- ⑥ In the Volkswagen emblem: radar sensor for assistance systems ⇒ *Exterior care and cleaning*
- ⑦ Opening lever for the hood with the engine compartment underneath ⇒ *Opening and closing the hood*
- ⑧ Windshield
 - With VIN ⇒ *Technical data*
 - With windshield wipers ⇒ *Operating the windshield wiper lever*
 - With camera window for assistance systems ⇒ *Exterior care and cleaning*
 - With rain/light sensor in the interior rearview mirror area ⇒ *Rain/light sensor, ⇒ Exterior care and cleaning*

Rear view

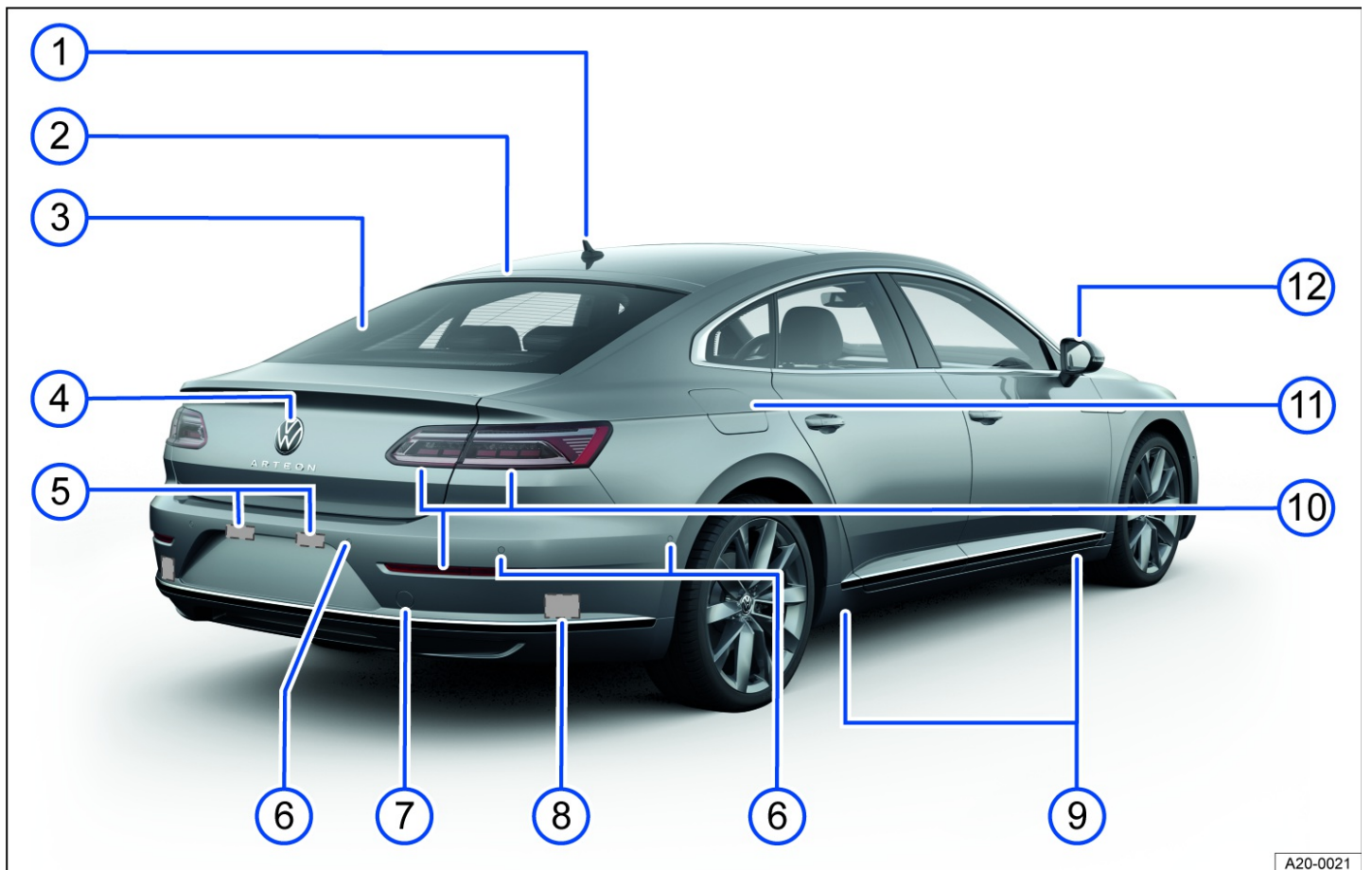

A20-0021

Fig. 3 Rear vehicle overview.

- ① Roof antenna ⇒ *Infotainment system and aerials*
- ② High-mounted brake light
- ③ Rear window
 - With rear window defroster ⇒ *Rear window defroster*
 - With window antenna ⇒ *Infotainment system and aerials*
- ④ Volkswagen emblem
 - for opening the trunk lid ⇒ *Trunk lid*
 - with camera for parking systems ⇒ *Rear View Camera*, ⇒ *Exterior care and cleaning*
- ⑤ Number plate light ⇒ *Exterior lighting*
- ⑥ Sensors for assistance systems ⇒ *Exterior care and cleaning*
- ⑦ Behind a cover: mount for towing eye ⇒ *Towing*
- ⑧ Behind the bumper: radar sensor for assistance systems ⇒ *Exterior care and cleaning*
- ⑨ Mounting points for the vehicle jack ⇒ *Wheel change*
- ⑩ Taillights and reflectors ⇒ *Exterior lighting*
- ⑪ Fuel filler flap ⇒ *Fuel types and refueling*
- ⑫ Outside mirrors ⇒ *Outside mirrors*
 - with Lane Change System (Side Assist) display ⇒  *Introduction*

Driver door



Fig. 4 Driver door: Controls.

- ① Door handle
- ② Central locking button to lock and unlock the vehicle ⇒ *Indicator light in the driver's door*
- ③ Central locking indicator light ⇒ *Central locking button*
- ④ Button to open the trunk lid 🚗 ⇒ *Trunk lid*
- ⑤ Storage compartment with cup holder
- ⑥ Storage compartment with storage option for a reflective vest ⇒ *Emergency equipment*
- ⑦ Door lights or reflectors
- ⑧ Button for deactivating the power window buttons in the rear doors 🚗 ⇒ *Opening and closing the windows*
- ⑨ Buttons for operating the power windows 🚗 ⇒ *Opening and closing the windows*
- ⑩ Knob for outside mirror positions and functions ⇒ *Outside mirrors*

Driver side

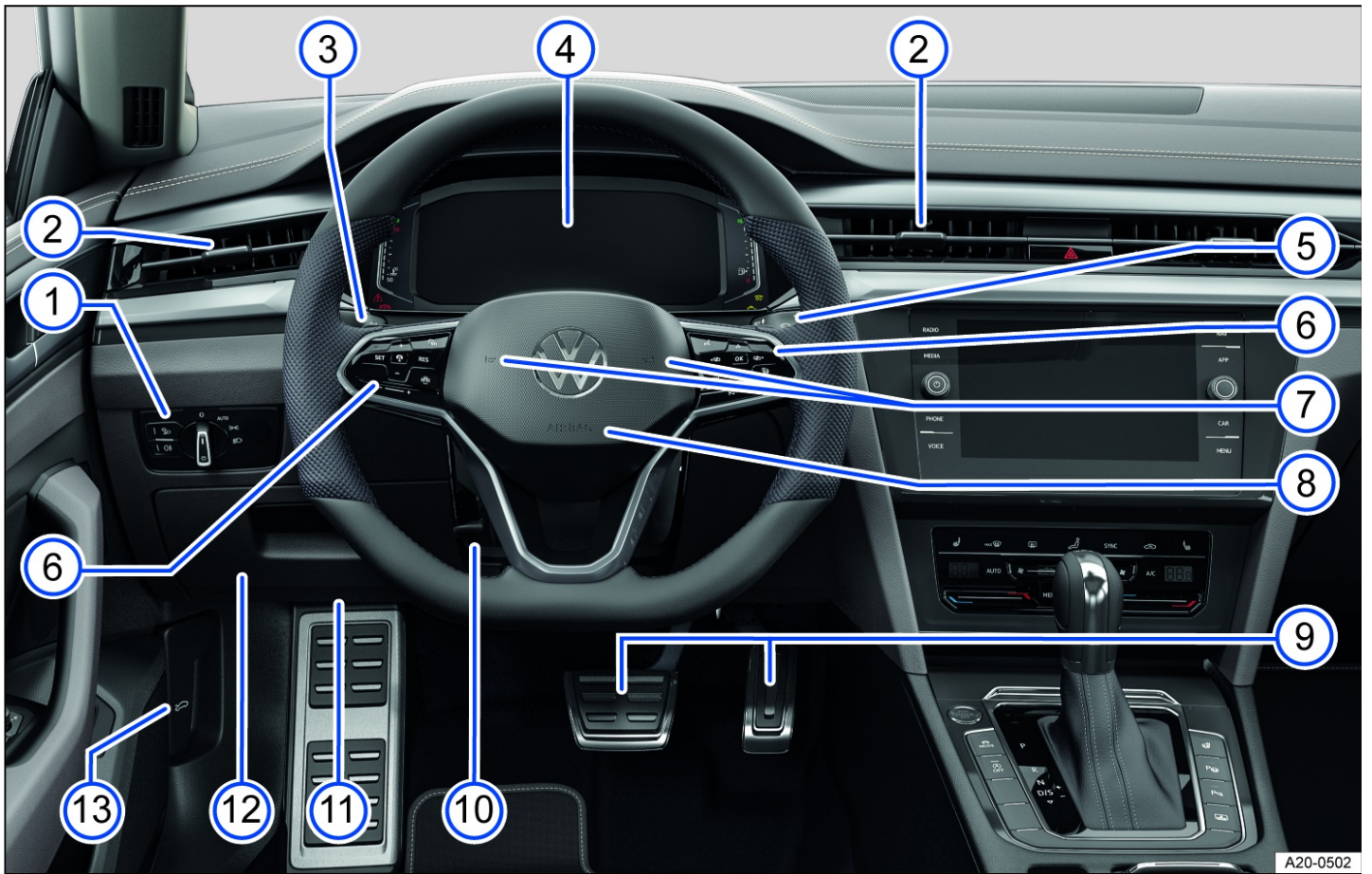

Fig. 5 Driver's side overview.

- ① Light switch ⇒ *Headlights*
- ② Vents ⇒ *Air distribution and blower speed*
- ③ Turn signal and high beam lever ⇒ *Switching the turn signals on and off, ⇒ Switching the high beam headlights on and off*
 - With switch and buttons for driver assistance systems ⇒ *Driver assistance systems*
- ④ Instrument cluster ⇒ *Overview of the Volkswagen Digital Cockpit Pro*
 - With warning and indicator lights ⇒ *Symbols in the instrument cluster*
- ⑤ Windshield wiper/washer lever ⇒ *Window wipers*
 - With buttons for menu operation ⇒ *Operating the Volkswagen Digital Cockpit Pro*
- ⑥ Multi-function steering wheel controls:
 - For driver assistance systems ⇒ *Driver assistance systems*
 - For menu selection ⇒ *Operating the Volkswagen Digital Cockpit Pro*
 - For steering wheel heating ⇒ *Steering wheel heating*
 - For accepting telephone calls **OK**
 - For audio, navigation ⇒ *Infotainment system, ⇒ Navigation*
 - For adjusting the volume **+**
 - For voice operation activation (may not function depending on the equipment) ⇒ *Voice control*
 - In order to switch between the current and previous menus **VIEW** ⇒ *Operating the Volkswagen Digital Cockpit Pro*
- ⑦ Horn
- ⑧ Installation location of driver's front airbag ⇒ *Airbag system*
- ⑨ Pedals ⇒ *Pedals*
- ⑩ Lever for adjusting the steering wheel position ⇒ *Steering wheel*
- ⑪ Knee airbag location ⇒ *Knee airbags*
- ⑫ Storage compartment

Center console

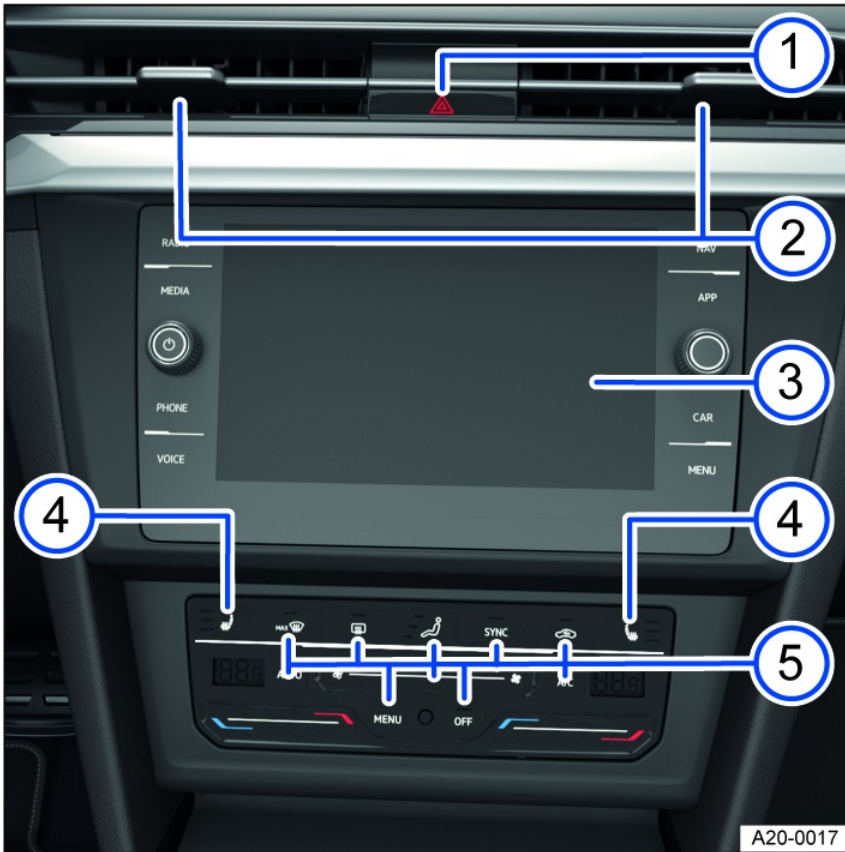



Fig. 6 Overview of the upper section of the center console.

- ① Button for switching the emergency flashers on or off  ⇒ *In case of an emergency*
- ② Vents ⇒ *Air distribution and blower speed*
- ③ Infotainment system ⇒ *First steps*
- ④ Buttons for seat heating and seat ventilation ⇒ *Seat heating and seat ventilation*
- ⑤ Controls for the climate control system ⇒ *Heating and air conditioning system*

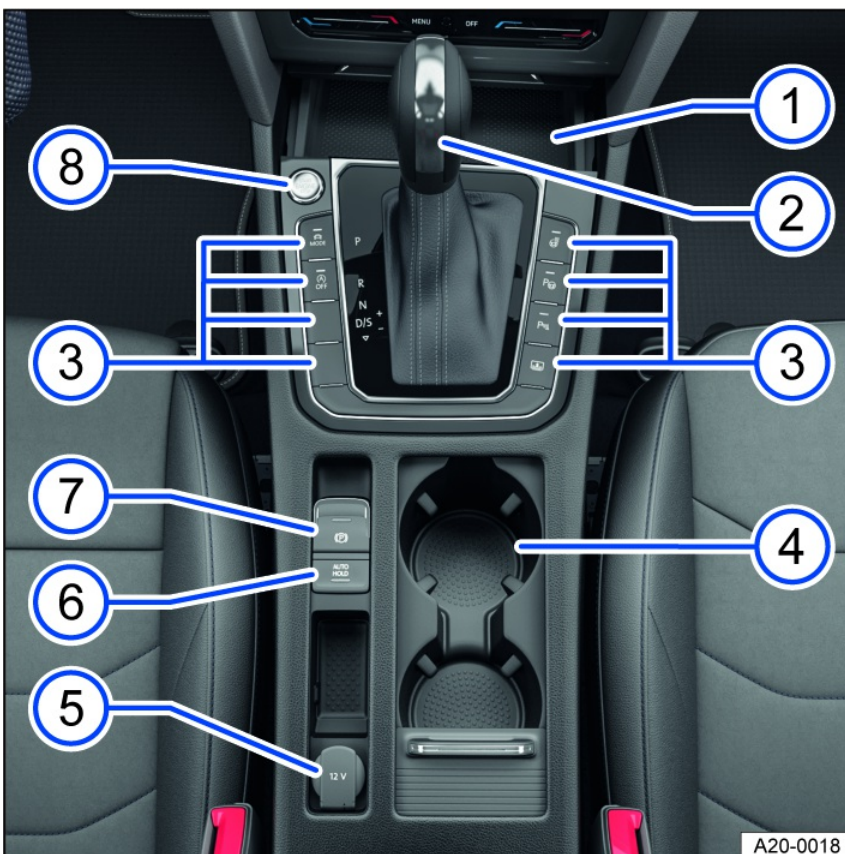

Fig. 7 Overview of the lower section of the center console.

- ① Storage compartment
 - With functionality for wireless charging in accordance with Qi standard ⇒ *Wireless charging function*
- ② Lever:
 - For DSG® automated transmission ⇒ *Automatic transmission*
- ③ Buttons:
 - For start/stop system ⇒ *Start/Stop system*
 - For assist systems for parking and maneuvering ⇒ *Parking and maneuvering*
 - for the Driving Mode Selection ⇒ *Driving Mode Selection*
 - For steering wheel heating ⇒ *Steering wheel heating*
- ④ Under a cover: Cup holder
- ⑤ 12 V socket ⇒ *Sockets*
- ⑥ Button for Auto Hold function ⇒ *Auto Hold*
- ⑦ Electronic parking brake ⇒ *Electronic parking brake*
- ⑧ Button to start and stop the engine (Keyless Access with push-button start) ⇒ *Starting and stopping the engine*

Passenger's side

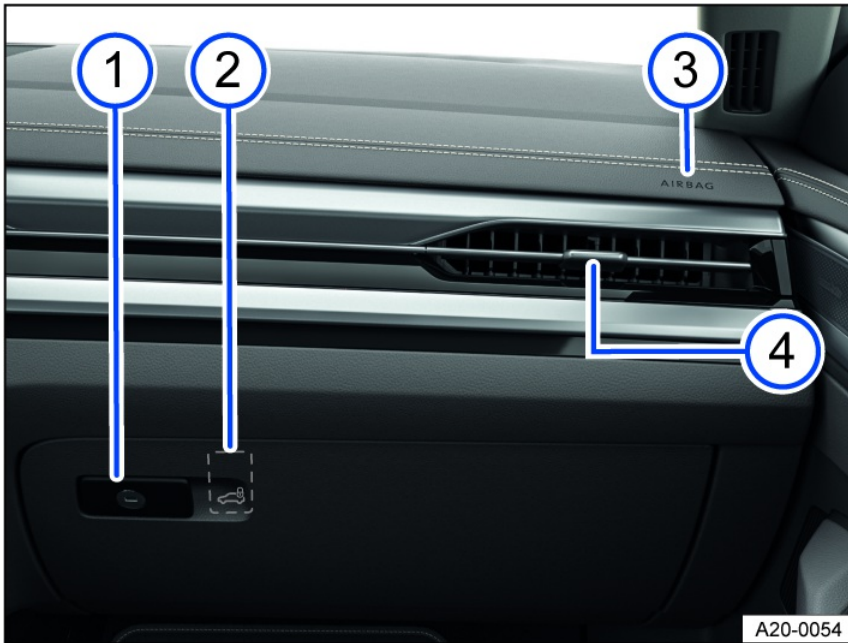

Fig. 8 Passenger's side: instrument panel overview

- ① Control lever for the glove compartment
- ② Button for the valet parking function (in the glove box) ⇒ *Emergency key (vehicle key without key bit)*
- ③ Installation location of the front passenger's airbag in the instrument panel ⇒ *Airbag system*
- ④ Vent ⇒ *Air distribution and blower speed*

Controls in the headliner

Symbol	Meaning
	Buttons for interior/reading lights ⇒ <i>Interior/reading lights, ambient lighting.</i>
	Sunroof switch ⇒ <i>Sunroof.</i>
	Buttons for Emergency Call, Information Call and Roadside Assistance Call ⇒ <i>Information Call, Roadside Assistance Call and Emergency Call Service.</i>

Driver information

Symbols in the instrument cluster





















The warning and indicator lights can turn on individually or in combination with each other and indicate warnings, malfunctions and certain functions. Some warning and indicator lights come on when you switch the ignition on and must turn off after some time.



















Indicator lights that turn on in the light switch are described in the “Lights” chapter ⇒ [Switching the lights on and off](#).





























⚠ WARNING





















Failure to respond to illuminated warning lights and messages may result in a vehicle breakdown, accidents and serious injuries or death.

- Never ignore illuminated warning lights and messages.
- Stop the vehicle as soon as it is safe to do so.

	 Do not continue driving! Central warning light ⇒ Priority 1 warning message
	Fasten safety belt ⇒ Fasten seat belts reminder and seat belt safety indicator
PARK	Electronic parking brake switched on ⇒ Electronic parking brake
	Holding force of the electronic parking brake too low ⇒ Holding force in the current situation is too low
BRAKE	 Do not continue driving! Brake system malfunction ⇒ Brake system malfunction
	 Do not continue driving! Electromechanical brake booster failed ⇒ Electromechanical brake servo failure
	 Do not continue driving! Brake fluid level too low ⇒ Brake fluid level
BRAKE WEAR	Check brake system ⇒ Brake pad wear indicator
	Take over steering and be ready to brake. ⇒  Introduction
	 Do not continue driving! Engine oil level too low ⇒ Engine oil level very low
	 Do not continue to drive! Engine oil pressure too low ⇒ Engine oil pressure too low
	 Do not continue to drive! Engine coolant system malfunction ⇒ Engine coolant
	 Do not continue driving! Steering malfunction ⇒ Steering malfunction
	Rear Traffic Alert has detected an obstacle to the rear ⇒ Rear Traffic Alert
	 Do not continue driving! 12 V energy supply malfunction ⇒ 12-volt power supply
	Collision warning ⇒ Warning levels and braking support

	Take over the steering immediately ⇒ <i>Take over the steering immediately</i>
	 Do not continue to drive! Transmission overheating ⇒ <i>Transmission overheating</i>
	Central warning light ⇒ <i>Priority 2 warning message</i>
	Airbag or safety belt pretensioner system deactivated with diagnostic equipment ⇒ <i>Airbag or safety belt pretensioner system deactivated with diagnostic equipment</i>
	Airbag system or safety belt pretensioner malfunction ⇒ <i>Airbag system or safety belt pretensioners malfunction</i>
OFF 	Front passenger's front airbag deactivated ⇒ <i>Front passenger's front airbag switched off</i>
	Emergency Call Service limited ⇒ <i>Emergency Call Service limited</i>
	Emergency Call Service malfunctioning ⇒ <i>Emergency Call Service malfunction</i>
	Electronic parking brake malfunction ⇒ <i>Electronic parking brake malfunction</i>
	Comes on: Electronic Stability Control (ESC) malfunction ⇒ <i>ESC malfunction</i>
	Flashes: Electronic Stability Control (ESC) or Anti-slip regulation (ASR) in operation ⇒ <i>Electronic Stability Control (ESC)</i>
	Electronic Stabilization Control (ESC) switched off ⇒ <i>ESC Off</i>
	Anti-Slip Regulation (ASR) switched off ⇒ <i>ASR</i>
ABS	Anti-Lock Braking System (ABS) malfunction ⇒ <i>ABS failure or malfunction</i>
	Engine oil system malfunction ⇒ <i>Engine oil system malfunction</i>
	Engine oil level too low ⇒ <i>Engine oil level too low</i>
	Engine oil level too high ⇒ <i>Engine oil level too high</i>
	Engine oil system malfunction ⇒ <i>Engine oil system malfunction</i>
	Tank almost empty ⇒ <i>Fuel tank almost empty</i>
	Travel Assist not available ⇒ <i>Comfort drive Travel Assist is not available or is not working as expected</i>
	Tank cap not closed ⇒ <i>Fuel tank cap open</i>
	Driving light failure ⇒ <i>Exterior lighting malfunction</i>
	Rain/light sensor malfunction ⇒ <i>Rain/light sensor malfunction</i> , ⇒ <i>Rain/light sensor malfunction</i>
	Windshield wiper malfunction ⇒ <i>Windshield wiper malfunction</i>
	Washer fluid level too low ⇒ <i>Washer fluid level too low</i>

	Steering malfunction ⇒ Steering malfunction
	 Do not continue to drive!
	Tire pressure low ⇒ Tire pressure low
	 Do not continue to drive!
	Tire pressure monitoring system malfunction ⇒ Tire pressure monitoring system malfunction
	Front Assist is switched off ⇒ Using Front Assist
	Autonomous Emergency Braking starts ⇒ Front Assist Starts
	Cruise control system malfunction ⇒ Cruise control system malfunction
	Speed warning ⇒ Driving data menu
	Adaptive cruise control (ACC) not available ⇒ ACC is not available
	Semi-automatic vehicle control in a medical emergency (Emergency Assist) is functioning ⇒ Driving with Emergency Assist
	Lane Assist in control ⇒ Driving with Lane Assist
	Side Assist malfunction ⇒ Lane change system malfunctioning
	Rear Traffic Alert brakes ⇒ Rear Traffic Alert
EPC	Engine control malfunction ⇒ Engine control malfunction
	Exhaust system malfunction ⇒ Exhaust-related malfunction
	Particulate filter clogged with soot ⇒ Particulate filter clogged with soot
	Engine RPM limited ⇒ Engine speed limited
	12-volt power supply malfunction ⇒ 12-volt power supply
	Transmission malfunction ⇒ Transmission overheating
	Adaptive chassis control (DCC) malfunction ⇒ Adaptive chassis control malfunction
	Vehicle key not in vehicle ⇒ Valid vehicle key cannot be detected
	Press the brake pedal. ⇒ The engine is not starting
	Turn signals ⇒ Turn signal indicator light
	Trailer turn signal ⇒ Trailer turn signal indicator light
	Cruise control switched on, regulation active ⇒  Introduction
	Lane Assist active ⇒ Driving with Lane Assist
	Comfort drive Travel Assist active ⇒  Introduction

	Adaptive Cruise Control (ACC) regulates, no vehicle driving ahead is detected ⇒ Switching ACC on and off
	Adaptive Cruise Control (ACC) regulates, vehicle driving ahead is detected ⇒ Switching ACC on and off
	High beams or headlight flasher ⇒ Switching the high beam headlights on and off
	Outside temperature is below +39 °F (+4 °C) ⇒ Volkswagen Digital Cockpit Pro Information Displays
	Start/Stop system active ⇒ Start-stop system
	Start/Stop system not available ⇒ Start-stop system
	Economical driving condition ⇒ Volkswagen Digital Cockpit Pro Information Displays
	Service due ⇒ Service interval display
	Travel Assist active, Adaptive Cruise Control active and adaptive lane guidance inactive ⇒ Introduction
	High beam control active ⇒ Switching on Light Assist
	Take over the steering ⇒ Take over the steering
	Autonomous Emergency Braking starts ⇒ Front Assist Starts
	Distance warning ⇒ Warning levels and braking support
	Eco driving mode ⇒ Driving mode properties
	Comfort driving mode ⇒ Driving mode properties
	Normal driving mode ⇒ Driving mode properties
	Individual driving mode ⇒ Driving mode properties
	Sport driving mode ⇒ Driving mode properties
	Mobile phone connected via Bluetooth® ⇒ Volkswagen Digital Cockpit Pro Information Displays
	Mobile phone battery charge level ⇒ Volkswagen Digital Cockpit Pro Information Displays
	Note about information in the Owner's Manual ⇒ Note about information in the Owner's Manual

Warning and information texts

The status of some functions inside the vehicle and vehicle components are checked when the ignition is switched on or while driving. Malfunctions are indicated by red and yellow warning symbols in the instrument cluster display and may also be signaled audibly in some cases. The appearance of texts and symbols may vary depending on the instrument cluster version.

Any malfunctions currently occurring can also be manually called up. To do this, open the Vehicle status or Vehicle menu. ⇒ [Vehicle settings menu](#)

Priority 1 warning message

The red central warning light flashes or comes on, in some cases together with warning tones or additional symbols.  **Do not continue driving!** There is a hazard. Check the malfunction. Contact an authorized Volkswagen dealer or authorized Volkswagen Service Facility immediately for assistance.

Priority 2 warning message

The yellow central warning light flashes or comes on, in some cases together with warning tones or additional symbols. Malfunctions or insufficient operating fluids can cause vehicle damage and vehicle malfunctions. Check the malfunction as soon as possible. Immediately contact an authorized Volkswagen dealer or authorized Volkswagen Service Facility to have the system checked. Volkswagen recommends contacting an authorized Volkswagen dealer or authorized Volkswagen Service Facility.

Note about information in the Owner's Manual

You can find more information about the existing warning message in the Owner's Manual.

Informational text

Information about various processes in the vehicle.

 **If there are multiple warning messages, the symbols will appear consecutively for several seconds. The symbols will appear until the malfunction is corrected.**

 **If warning messages about malfunctions appear when the ignition is switched on, settings or information displays may not appear as described. If the malfunction persists, contact a suitably qualified professional. Volkswagen recommends contacting an authorized Volkswagen dealer or authorized Volkswagen Service Facility.**

Introduction to the instrument cluster

The vehicle is equipped with a Volkswagen Digital Cockpit. The instrument cluster shows essential information, such as speed.

In addition, the following functions, among others, are available depending on the equipment:

- Various menus, such as for the driver assistance systems.
- Status displays for the driver assistance systems.
- Display messages.
- Warning and indicator lights.
- Information about economy and range.

Content can be individually adapted and settings can be changed in the menus.

WARNING

If the driver is distracted while driving, accidents and serious injuries can occur.

- Never operate the instrument cluster while driving.
- Only adjust any settings in the instrument cluster or Infotainment system when the vehicle is stationary.

WARNING

If there is a serious fault in the instrument cluster, the display may be turned off. The warning light  may also come on here.

- Safely stop the vehicle.
- See an authorized Volkswagen dealer or authorized Volkswagen Service Facility for assistance.

 **After starting the engine when the 12 V vehicle battery is severely drained or when it has been replaced or jump-started, the system settings, e.g. personal convenience settings and programming, and user profiles may be changed or erased. Check and correct the settings after the 12 V vehicle battery is sufficiently recharged.**

Volkswagen Digital Cockpit Pro

Overview of the Volkswagen Digital Cockpit Pro

The Volkswagen Digital Cockpit Pro is a digital instrument cluster with a high-resolution TFT color display. By selecting different information profiles, other displays can be shown in addition to the standard dials, such as the tachometer. The term Volkswagen Digital Cockpit Pro is used to refer to the "Pro digital instrument cluster" in the following.

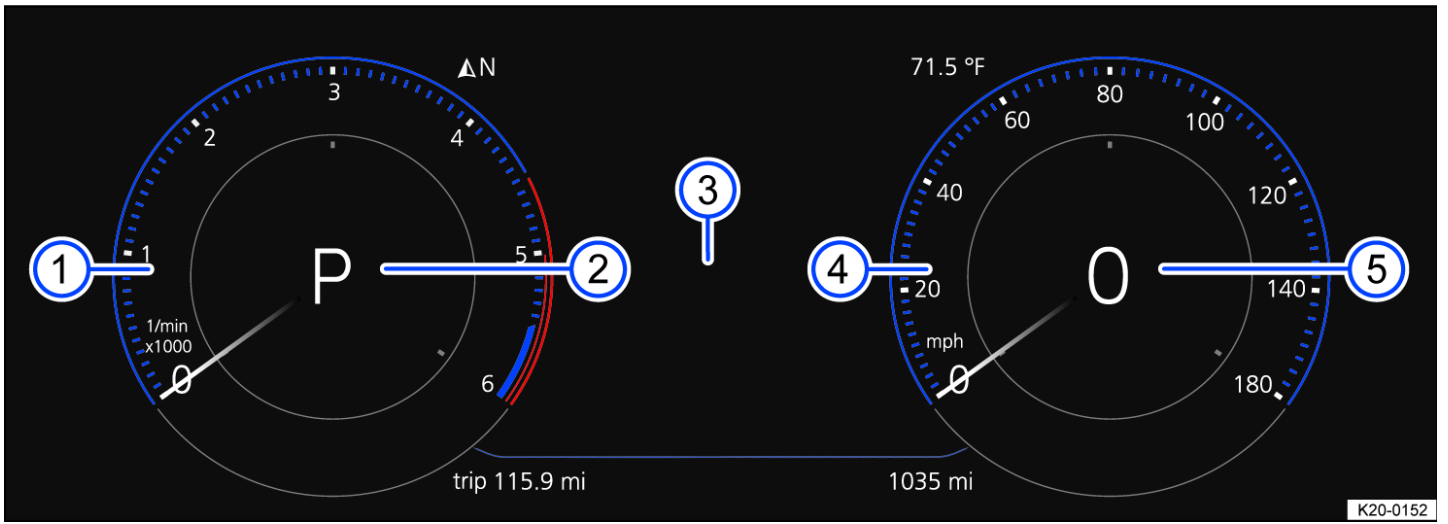

Fig. 9 Volkswagen Digital Cockpit Pro in the instrument panel (general example).

- ① Tachometer (RPM of the running engine).
- ② Currently engaged gear or selector lever level ⇒ *Driving*.
- ③ Displays ⇒ *Operating the Volkswagen Digital Cockpit Pro*.
- ④ Speedometer.
- ⑤ Digital speed display.

Operating the Volkswagen Digital Cockpit Pro



Fig. 10 Right side of the multi-function steering wheel: Operating the Volkswagen Digital Cockpit Pro (variant 1).





Fig. 11 Right side of the multi-function steering wheel: Operating the Volkswagen Digital Cockpit Pro (variant 2).

Vehicles with multi-function steering wheel: Menus cannot be accessed when a priority 1 warning message is displayed → page , *Warning and information texts*. You can confirm and hide some messages using the **OK** button on the multi-function steering wheel [fig. 10](#), [fig. 11](#).



Selecting a menu or information display

Vehicles with multi-function steering wheel:

1. Switch the ignition on.
2. If a message or vehicle icon is displayed, press the **OK** button, repeatedly if necessary.
3. To display a menu and to scroll through the menu, press the  or  button.
4. To open the displayed menu or information display, press the **OK** button or wait until the menu or the information display opens automatically after several seconds.

Applying settings in the menus

Vehicles with multi-function steering wheel:

1. Press the  or  arrow button in the displayed menu until the preferred menu item is highlighted.

The item is marked with a frame around it.

2. Press the **OK** button to apply the desired changes.

A check mark indicates that the respective function is switched on.

3. To return to the menu selection, press the  or  button.

VIEW button on multi-function steering wheel

You can use the **VIEW** button to switch between the classic display of dials, the large platform without information profiles, and the enhanced view with highlighted information profiles. The classic display shows the large dials on the right and left side, and the selected information profile is displayed in the center.

1. Press and hold the **VIEW** button to select from the preset information profiles in the list:

Classic View without information profiles.

Automatic The information profiles adjust to the selected driving mode. Only for vehicles with Driving Mode Selection.

Preset 1 Individual selection of information profiles

Preset 2 Individual selection of information profiles

Preset 3 Only on vehicles with standard factory-installed navigation system.

Navigation map in the Volkswagen Digital Cockpit Pro

Depending on the vehicle equipment, the Volkswagen Digital Cockpit Pro may display a detailed navigation map.

The navigation map can be displayed in three sizes. With the larger map view, the navigation map is shown across the entire display. To select the desired map size, proceed as follows:

1. Select menu item Navigation.
2. Press the **VIEW** button on the multi-function steering wheel to switch between the map sizes.
3. Press the **▲** or **▼** arrow buttons on the multi-function steering wheel to zoom in or out.
4. When zooming manually, press the **OK** button on the multi-function steering wheel to switch to auto-zoom.

Depending on the equipment, navigation will be shown on two screens or only on one screen. The navigation map may appear in the Volkswagen Digital Cockpit Pro and in the Infotainment system or just in the Infotainment system. If the navigation map is shown in the Infotainment system, only navigation arrows are shown the Volkswagen Digital Cockpit.

If warning messages about malfunctions appear when the ignition is switched on, settings or information displays may not appear as described. If the malfunction persists, contact a suitably qualified professional. Volkswagen recommends contacting an authorized Volkswagen dealer or authorized Volkswagen Service Facility.

WARNING

If the driver is distracted while driving, accidents and serious injuries can occur.

- Never operate the Volkswagen Digital Cockpit Pro while driving.
- Only adjust any settings in the Volkswagen Digital Cockpit Pro or Infotainment system when the vehicle is stationary.

Volkswagen Digital Cockpit Pro Information Displays

Information profiles

Using the Volkswagen Digital Cockpit menu item in the Infotainment system vehicle settings, you can select different, topic-specific information profiles ⇒ [Vehicle settings menu](#). Depending on the selected information profile, the Volkswagen Digital Cockpit Pro may show additional information in the center of the dials or the dials may be hidden and the additional information shown across the entire display. The following information profiles can be selected:

- Audio. Digital display of the current audio playback
- Comfort drive Travel Assist. Visual display of various driver assistance systems ⇒ [Driver assistance systems](#).
- Distance Display of the distance driven.
- Gear indicator Display of the current gear or the selected gear.
- Speed Display of the speed.
- Navigation Graphic display of arrow navigation
- Range. Display of the range.
- Consumption Graphic display of the current consumption and the digital display of the average consumption
- Traffic sign recognition Display of detected traffic signs.
- Destination arrival information. Display of remaining driving time, the distance to the destination, and the estimated arrival time.

Depending on the equipment, the number and scope of the information profiles that can be selected may vary.

Possible displays in the Volkswagen Digital Cockpit Pro

Depending on the vehicle equipment, different information may be shown in the Volkswagen Digital Cockpit Pro:

- Outside temperature display.
- Detected road sign from the traffic sign recognition.
- Driver assistance systems.
- Driving data menu and menus for various settings.
- Speed warnings.
- Speed warning for winter tires.
- Open doors, hood and trunk lid.
- Infotainment system and navigation information.
- Odometer displays.

- Compass display.
- Radiator fan run-on.
- Engine code ().
- Service interval display.
- Status display for the start-stop system ⇒ [Start/Stop system](#).
- Phone information.
- Time.
- Selector lever position.
- Warning and information texts.
- Warning and indicator lights ⇒ [Symbols in the instrument cluster](#).
- Depending on the vehicle equipment: Fuel-efficient driving . Status display for Active Cylinder Management (ACT) ⇒ [Eco tips](#).

Outside temperature display

When outside temperatures are colder than approximately +4°C (+39°F), a snowflake symbol also appears on the outside temperature display ❄️. This symbol remains on until the outside temperature rises above +43 °F (+6 °C).

In the following situations, the temperature displayed may be higher than the actual outside temperature due to heat radiating from the engine:

- When the vehicle is stationary
- When the driving speed is very low

The measurement range is from -45 °C (-49 °F) to +169 °F (+76 °C)

WARNING

Streets and bridges may be icy when outside temperatures are above the freezing point.

The ❄️ snowflake symbol indicates a possible risk of black ice.

Black ice may also be present when outside temperatures are above +39 °F (+4 °C) when the ❄️ snowflake symbol is not displayed.

- Never rely solely on the outside temperature display.

Open doors, hood and trunk lid

If, after unlocking the vehicle and while driving, any doors and/or the hood or trunk lid are open, this is displayed in the Volkswagen Digital Cockpit and an audible signal may also sound.

Speed warning for winter tires

If the set maximum speed is exceeded, this will be shown in the digital instrument cluster.

Settings for the speed warning can be adjusted in the vehicle settings in the Infotainment system ⇒ [Winter tires](#).

Compass display

When the ignition is switched on, the instrument cluster display shows an abbreviation to indicate the direction the vehicle is currently traveling, for example “NW” for northwest.

If the Infotainment system is switched on and route guidance is not active, the graphic display of a compass is also available.

Odometer displays

The odometer registers the total distance that the vehicle has driven.

The trip odometer shows the miles that were driven since the trip odometer was last reset.

1. Reset the odometer via the Infotainment system or the service menu ⇒ [Service menu](#).

Radiator fan run-on

This indicator appears after the ignition has been switched off, if the radiator fan continues to run.

The radiator fan may continue running due to:

- Exhaust gas post-treatment, through particulate filter regeneration, for example.
- Active brake cooling after descent.
- Dissipation of engine heat after high load, e.g. trailer mode.

Engine code

1. Open the service menu ⇒ [Service menu](#).

2. Select the Engine code menu item.

Phone information

If a cell phone is connected via Bluetooth, the Bluetooth symbol  will be displayed in the Volkswagen Digital Cockpit.

The  symbol also indicates the charge level of the mobile device.

Selector lever position

The selector lever position that is engaged is shown on the left side of the selector lever and in the Volkswagen Digital Cockpit.

If necessary, the respective gear is displayed in the Volkswagen Digital Cockpit when in the D/S selector lever position and when in tiptronic mode \Rightarrow *Automatic transmission: selecting the selector lever position.*

Fuel-efficient driving

If the vehicle is driving in a fuel-efficient manner, this will be indicated in the Volkswagen Digital Cockpit while driving .

 Suitably qualified professionals can program or modify additional functions depending on the vehicle equipment. Volkswagen recommends contacting an authorized Volkswagen dealer or authorized Volkswagen Service Facility.

 There are different instrument clusters; therefore the versions and appearances of the displays may vary. Malfunctions will only be indicated by indicator lights if the display does not have warning or information texts.

 Some displays in the Volkswagen Digital Cockpit may be hidden due to events that occur suddenly, e.g. incoming phone calls.

 Depending on the equipment, some settings and displays may also appear in the Infotainment system.

Tachometer

The start of the red area on the tachometer indicates the maximum permissible engine speed for all gears when the engine is run in and at operating temperature.

Before reaching the red area, shift to the next highest gear, select the selector lever position D/S or take your foot off the accelerator pedal.

NOTICE

- Avoid high engine speeds, full acceleration and heavy engine loads when the engine is cold.
- To prevent engine damage, the tachometer indicator may only be in the red area of the scale briefly.

 Shifting up early helps save fuel and reduce operating noises.

Fuel gauge

Digital fuel gauge

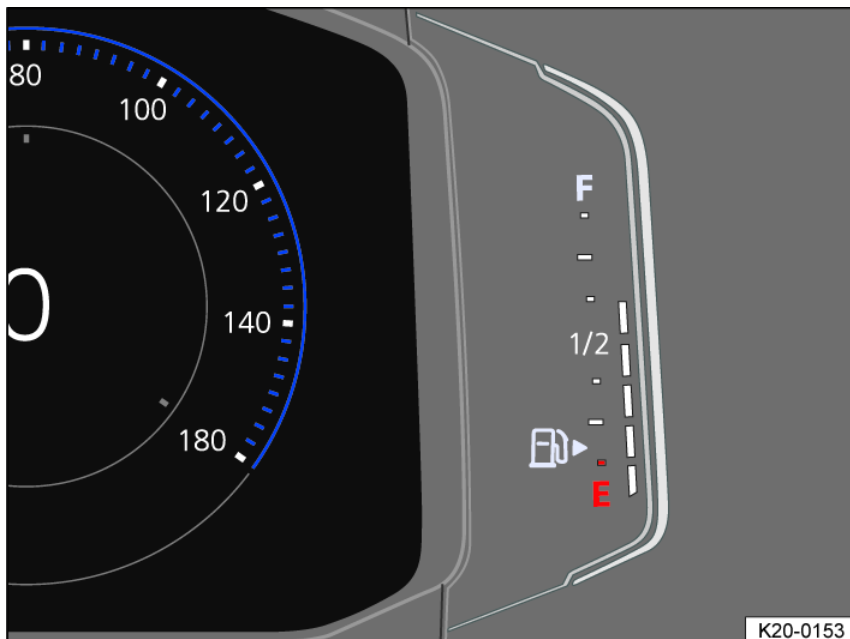

Fig. 12 Fuel gauge on the Volkswagen Digital Cockpit Pro (general example).

WARNING

Driving with low fuel level that is too low can lead to a vehicle breakdown in traffic, accidents, and serious injuries.

- If the fuel level is too low, this can result in irregular fuel supply to the engine, particularly when going uphill or downhill.
- The steering, all driver assistance systems and brake support systems will not work if the engine is “sputtering” or cuts out due to fuel shortage or irregular fuel supply.
- To prevent vehicle breakdown due to low fuel, always refill the fuel tank once it reaches a fill level of 1/4.

NOTICE

Never drive with a completely empty fuel tank. Irregular fuel supply can result in misfiring and unburnt fuel entering the exhaust system.

 The small arrow next to the fuel pump symbol on the fuel gauge indicates which side of the vehicle the fuel filler flap is on.

Troubleshooting

Fuel tank almost empty

The yellow indicator light turns on. The reserve supply (red marking) is being used.

1. Refuel at the next opportunity.

Fuel tank cap open

The yellow indicator light turns on.

1. Close the fuel tank cap.

Engine coolant temperature gauge

Digital coolant temperature gauge

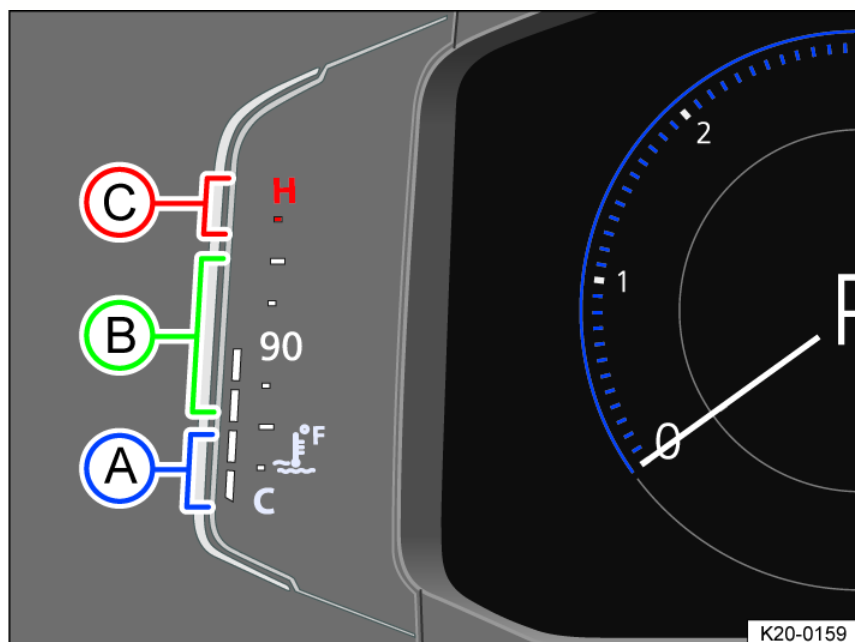



Fig. 13 Coolant temperature gauge in the Volkswagen Digital Cockpit Pro (general example).

- A** Cold range. The engine is not at operating temperature yet. Avoid high engine RPMs and heavy engine load when the engine is not at operating temperature.
- B** Normal range.
- C** Warning range. The needle may move into the warning range when engine load is heavy, especially when outside temperatures are high.



If the  warning light flashes, the coolant temperature is too high or the coolant level is too low ⇒ [Troubleshooting](#).

Driving data menu

The driving data menu shows driving and consumption data. Depending on the vehicle equipment, various driving data can be displayed. The displayed driving data is dependent on the current driving style, the vehicle status, e.g. particle filter regeneration, and the current driving situation, e.g. city traffic. The driving data is determined as an average value over sections of different distances and the currently displayed value may therefore differ from the actual average value.

Switching between the displays

Vehicles with multi-function steering wheel:

1. Press the  or  button on the multi-function steering wheel.

Switching memories

Vehicles with multi-function steering wheel:

1. Press the  button on the multi-function steering wheel.

Since start memory

If the trip is interrupted for more than two hours, the memory is erased.

Since refuel memory

Display and memory of the collective driving and consumption data. The memory is erased when the vehicle is refueled.

Extended period memory

The memory collects the driving data up to 19 hours and 59 minutes or 99 hours and 59 minutes driving time or 1999.9 km (miles) or 9999.9 km (miles) distance driven. If one of these maximum thresholds is met, the memory is erased. The maximum thresholds may vary depending on the version of the instrument cluster.





Erasing the driving data memory

Vehicles with multi-function steering wheel:

1. Select the memory to be erased.
2. Press the  button on the multi-function steering wheel.

Setting a speed warning

Vehicles with multi-function steering wheel:

1. Select the Warning at --- km/h or Warning at --- mph display.
2. Press the  button on the multi-function steering wheel to save the current speed and to activate the warning.
3. Set the speed on the multi-function steering wheel within approximately five seconds by pressing the  and  arrow buttons. Then press the  button or wait several seconds.

The speed will then be saved and the warning will be activated.

4. Press the  button again to deactivate.

The stored speed is erased.

The warning can be set for speeds between 18 mph (30 km/h) and 155 mph (250 km/h).

Depending on the country, a single warning tone sounds at speeds of over approximately 80 km/h (approximately 50 mph), and from approximately 120 km/h (approximately 75 mph), a continuous warning tone sounds. The  indicator light will also be displayed in the instrument cluster display. This warning is required by law and cannot be altered.

Driving Data in the Infotainment system

Driving Data can be displayed in the Infotainment system, in addition to being displayed in the instrument cluster.

Selecting Displays

You can select the driving data you would like to display using the vehicle settings in the Infotainment system ⇒ [Vehicle settings menu](#).

Consumption

The average fuel consumption is displayed after approximately 300 m (984 ft).

Range

This indicates the approximate distance in km (miles) the vehicle can travel under the same driving conditions.

Speed

The average speed is displayed after approximately 100 m (approximately 328 ft).

WARNING

If the driver is distracted while driving, accidents and serious injuries can occur.

- Never operate the instrument cluster while driving.
- Only adjust any settings in the instrument cluster or Infotainment system when the vehicle is stationary.

Service

Service menu

Depending on the equipment, settings can be applied in the service menu.

Opening the Service Menu

1. Select the Range information profile in the instrument cluster.

2. Press and hold the **OK** button on the multifunction steering wheel for approximately four seconds.
3. Navigate in the menu using the buttons on the multi-function steering wheel.

Resetting the service interval display

1. Select Service menu.
2. Follow the instructions in the instrument cluster display.

Resetting the oil change service

1. Select Reset oil change service menu.
2. Follow the instructions in the instrument cluster display.

Resetting the trip odometer

1. Select Reset trip menu.
2. Follow the instructions in the instrument cluster display.

Displaying the engine code

1. Select Engine code menu.

The engine code is shown on the instrument cluster display.

Setting the time

1. Select Time menu.
2. Set the time with the **Δ** and **▽** arrow buttons.

Displaying copyright information

1. Select the Copyright menu to access the copyright information.

Service interval display

Displays about service events appear in the instrument cluster display and in the Infotainment system. There are different versions of the instrument cluster and Infotainment system; therefore, the appearances of the displays may vary.

Service appointments at Volkswagen are divided into oil change services and inspections. The service interval display informs the driver about the next service appointment which includes an engine oil change and about the next inspection.

The service intervals are specified for vehicles with the fixed oil change service interval.

Intervals are determined individually on vehicles with the flexible oil change service interval. Oil change services only need to be performed if the vehicle requires it. The specific operating conditions and the personal driving style are also taken into consideration. The service early warning message is first displayed 30 days prior to the calculated oil change service due date. The displayed remaining distance to be traveled is always rounded to 100 km (miles) and the remaining time is rounded to whole days.

Service notification

If an oil change service or an inspection service is due in the near future, a service notification will be displayed when the ignition is switched on.

The specified mileage or time is the distance or time until the next service can be completed.

Service event

When an oil change service or an inspection service is due, a chime will sound when switching on the ignition and you can then see a wrench symbol  for a few seconds in the instrument cluster display together with one of the following displays:

- Inspection now!
- Oil change now!
- Oil change service and inspection now!

Checking a service due date in the Infotainment system

When the ignition is on, the engine is off, and the vehicle is stationary, the current service due date can be viewed at any time:

1. Depending on the vehicle equipment, press the **MENU** button or function key and select the Vehicle menu in the Infotainment system.
Or: depending on the vehicle equipment, press the **CAR** button or function key.
2. Depending on how your vehicle is equipped, select the Settings menu.
3. Select the Service menu item to display the service information.

Checking a Service Due Date in the Volkswagen Digital Cockpit Pro

When the ignition is on, the engine is off, and the vehicle is stationary, the current service due date can be viewed at any time:

1. Open the service menu ⇒ *Service menu*.

Resetting the service interval display

If the service interval display was not reset after the oil change service or inspection service, the display can be reset as follows:

Vehicles with a digital instrument cluster: The service interval display can only be reset through the service menu ⇒ *Service menu*.

Do not reset the service interval display between service intervals or incorrect information will be displayed.

If the oil change service interval was manually reset, the service interval display then also switches to a fixed service interval, even on vehicles with the flexible oil change service interval.

 The service message disappears automatically after a few seconds when the engine is running or when the **OK** button on the multi-function steering wheel is pressed.

 If the 12 V vehicle battery in a vehicle with the flexible service interval has been disconnected for an extended period, the time for the next oil change service cannot be calculated. Therefore, the service interval displays may show incorrect calculations. If this is the case, follow the maximum permissible maintenance intervals.

Time

Setting the time in the Infotainment system

1. Depending on the design, press the **MENU** button or function key and open the Vehicle menu.

Or: depending on the vehicle equipment, press the **CAR** button or function key.

2. Depending on how your vehicle is equipped, open the Settings menu.

3. Select the Time and date menu item to set the time.

Setting the Time in the Volkswagen Digital Cockpit Pro

1. Select the Range information profile.

2. Press and hold the **OK** button on the multi-function steering wheel until the service menu is available in the instrument cluster display ⇒ *Service menu*.

3. Select Time menu.

4. Set the correct time using the **Δ** or **∇** arrow buttons.

Sport displays

Lap timer in the instrument cluster

The lap timer offers the option to measure and save the individual lap times on a race course manually in the vehicle as well as compare these times to the best times previously recorded.

Depending on the equipment, the lap timer can be displayed in the instrument cluster.

The following main menus can be displayed:

- Lap timer.
- Lap (with current lap specification).
- Statistics.

Switching between menus

1. Press the **Δ** or **∇** button on the multi-function steering wheel.

For example, the following list will show the layout of the menus in the instrument cluster display. The actual scope of the menus and the names of individual menu items depend on the instrument cluster version and the vehicle electronics.

Menu displays and functions

Lap timer menu:

Start The time measurement of a lap is started.

Since start The time measurement begins when the vehicle begins to drive. If it is already moving, the time measurement starts when the vehicle comes to a stop in the meantime.

Statistics An overview of the laps previously recorded is displayed.

Lap menu:

Stop The active time measurement is paused. The lap is not finished.

Resume The paused time measurement is resumed.

Split time A split time is displayed for approximately five seconds. The active time measurement continues to run simultaneously.

New lap The time of the current lap is stopped and a new lap is started. The time for the finished lap is transferred to the statistics.

Cancel lap The time measurement is stopped and discarded. The current lap will not be recorded in the statistics.

End The time measurement is finished. The lap will be recorded in the statistics.

Statistics menu:

Back The display switches back to the previous menu.

Reset All saved statistics data is reset.

The previously driven lap times are displayed in the Statistics menu. If the maximum lap number of 99 laps or the maximum total duration of 99 hours, 59 minutes and 59 seconds is reached, a new time measurement can be started before the statistics are reset.

⚠ WARNING

Driver distraction can cause accidents and injuries.

- Only adjust lap timer presets and open the statistics when the vehicle is stationary.
- Only operate the lap timer while driving if the driving situation is easy to control and monitor.

Infotainment system lap timer

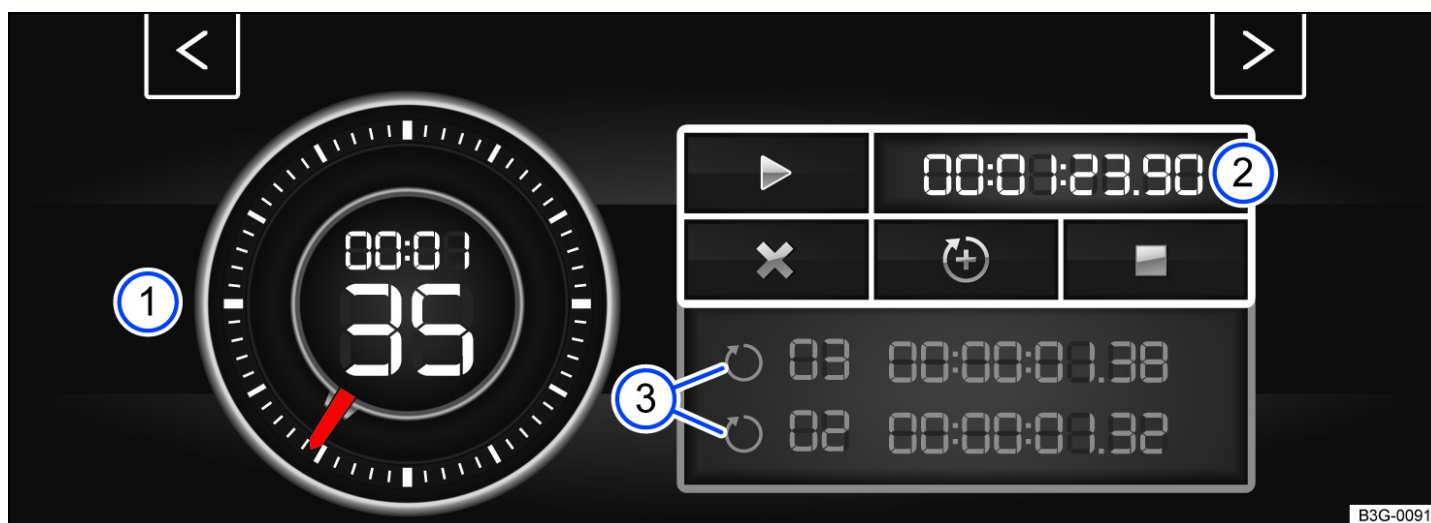

Fig. 14 On the Infotainment system screen: lap timer with stopwatch, function key, and lap times.

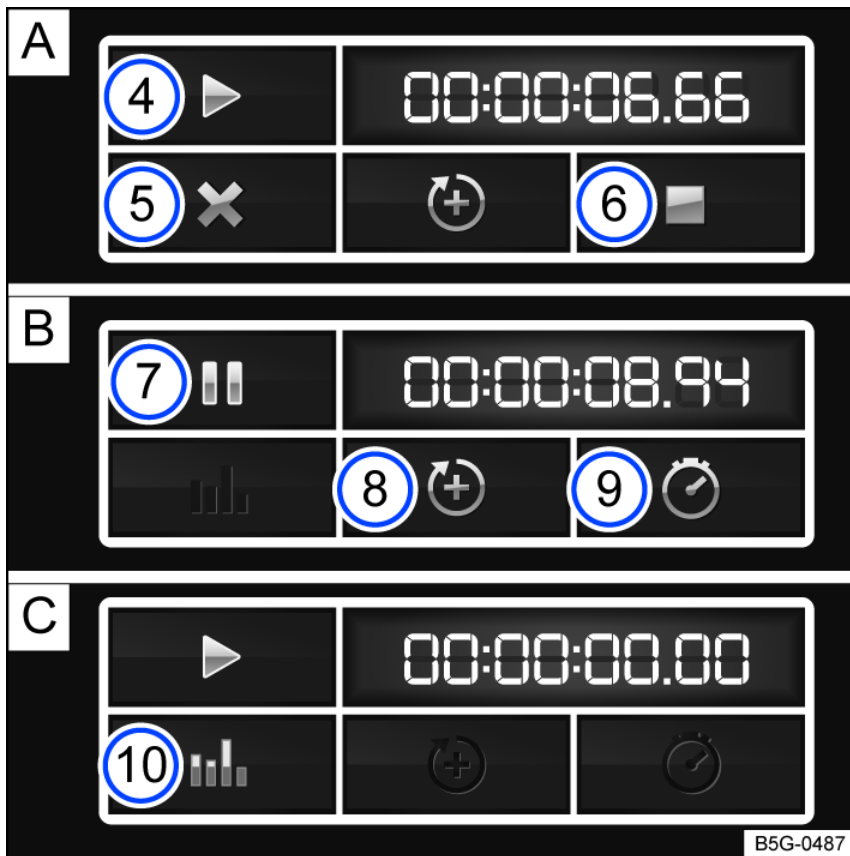

Fig. 15 Function key on the Infotainment system screen: time measurement when the lap is **A** stopped, **B** running, and **C** finished.

- ① Stopwatch
- ② Function key with current lap time
- ③ Saved lap times
- ④ Start or resume time measurement; this is only possible when the ignition is switched on. Tap Start to begin the time measurement. The time measurement starts automatically once the vehicle moves forward. If the data has been reset in the statistics, a new first round can be started.
- ⑤ Cancel the current lap. The lap time is deleted. --:--:-- is displayed in the statistics.
- ⑥ End the time measurement.
- ⑦ Stop the time measurement or cancel the current lap when the time measurement is running.
- ⑧ Start new lap. The last lap time is saved and a new lap time starts. The total time of the laps is displayed in the statistics.
- ⑨ Display the split time. The stopwatch stops for several seconds and the split time is displayed.
- ⑩ Display the statistics after ending or canceling the time measurement: number of laps, total time, fastest and slowest lap, average lap time of all laps, all lap times). Tap Reset to reset the statistics.

i A maximum of 99 laps and a maximum duration of 99 hours, 59 minutes and 59 seconds can be recorded. If one of these limits is reached, data in the statistics must be deleted before starting another time measurement.

Opening the lap timer

1. Depending on vehicle equipment, press the **(MENU)** button or function key.
 - Or: press the **(CAR)** button or function key.
 - Or: tap the **(⚙️)** function key.
2. Tap the **(Vehicle)** function key.
 - Or: tap **(Auto)** function key.
3. Tap the **(Selection)** function key.
4. Tap the **(Sport)** function key.

The performance monitor will be displayed.
5. Tap one of the arrow buttons in the performance monitor to switch to the lap timer.

You can switch between the lap timer and performance monitor using the arrow buttons.

Measuring lap times

The stopwatch measures the lap time in two areas:

The red needle and the number in the center indicate the running time in seconds, and the smaller display in the inner area shows minutes and hours.

The display on the right side shows the current lap time with an accuracy of 1/100 of a second. If no laps with split times have been saved yet in the lap timer, then there is no difference between the stopwatch and the lap time.

⚠ WARNING

Driver distraction can cause accidents and injuries.

- Only adjust lap timer presets and open the statistics when the vehicle is stationary.
- Only operate the lap timer while driving if the driving situation is easy to control and monitor.

Performance monitor

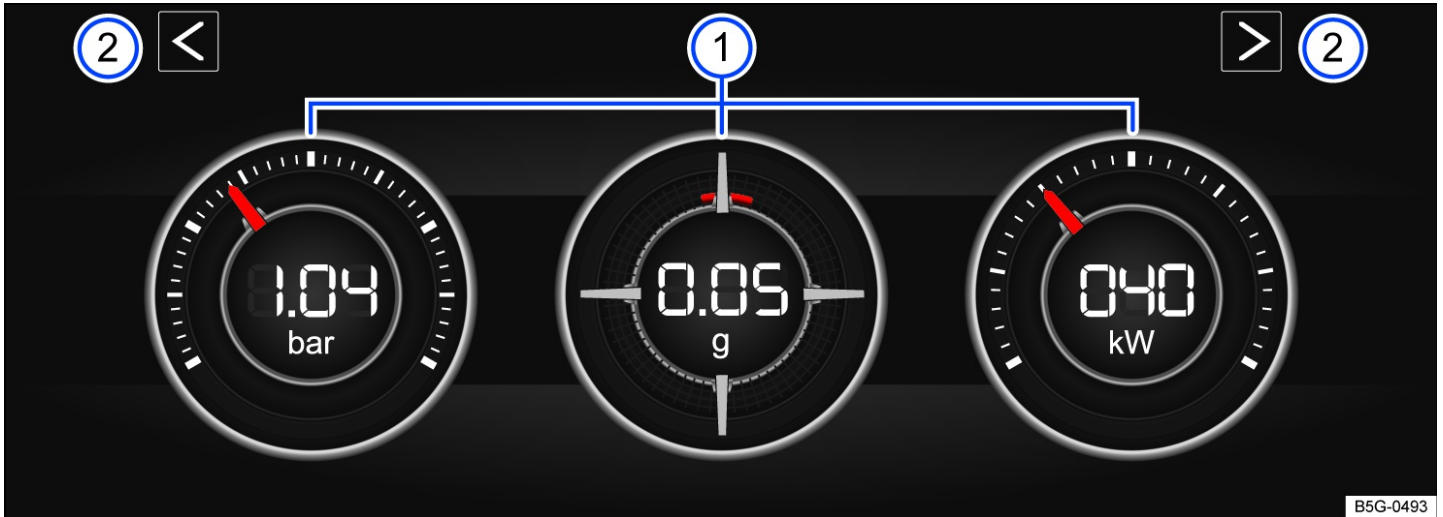

Fig. 16 On the Infotainment system screen: performance monitor.

- ① Displays
- ② Arrow buttons to switch to the lap timer

The performance monitor is a display for sporty driving. The digital instruments show values in real time for engine power, temperature, and acceleration that are determined by sensors in the vehicle. This gives the driver an overview of the driving dynamics.

Opening the performance monitor

1. Depending on the version, press the **MENU** button or function key in the Infotainment system.
2. Tap the **(Vehicle)** function key.
3. Tap the **(Selection)** function key.
4. Tap the **(Sport)** function key.

If you want to switch between the performance monitor and the lap timer, tap one of the left or right arrow buttons above the instruments [fig. 16 ②](#).

Selecting instruments and adjusting units

The display can show a maximum of three instruments at the same time. Every instrument can be selected for any display area [fig. 16 ①](#) (left, center, right).



1. To switch between instruments, swipe up over the display.

The instrument that is currently selected will disappear and a new instrument will appear.

The units on some instruments can be adjusted in the Infotainment system ⇒ [Vehicle settings menu](#).

The following instruments can be displayed:

- **Boost pressure indicator:** the boost pressure indicator [fig. 16 ①](#) (left) displays the boost pressure between the turbocharger and the engine in bar. The farther to the right that the needle on the scale is, the more engine power is being used.
- **Accelerometer (g-meter):** the accelerometer (g-meter) [fig. 16 ①](#) (center) displays the acceleration value in the center area in g. The red marking in the tab area shows the intensity of the acceleration and the direction of the force. The force in effect is contrary to the physical laws. For example, if you drive to the left, the red marking will move in the right area of the instrument and vice versa. When accelerating, the red marking will move downward. When braking, the red marking will move upward. The intensity of acceleration is indicated by the position of the red marking from the inside to the outside. If you accelerate faster, the red marking will disappear from the center area.

- **Power gauge:** the power gauge [fig. 16](#)  (right) shows the engine power that is being currently used as a digital value displayed on the surrounding scale in kW.
- **Engine coolant temperature gauge:** when engine load is heavy and outside temperatures are high, the gauge may move farther to the right. This is not a cause for concern as long as the  indicator light in the instrument cluster display is off or blinking ⇒ [Checking and filling engine coolant](#).
- **Oil temperature gauge:** the needle stays in the center area under normal driving conditions. If the pointer is in the left, lower area, the engine operating temperature has not yet been reached. If the engine operating temperature has not been reached yet, avoid excessive high speeds and acceleration. Engine coolant temperature gauge: when engine load is heavy and outside temperatures are high, the gauge may move farther to the right. This is not a cause for concern as long as the  indicator light in the instrument cluster display is off or blinking ⇒ [Troubleshooting](#).

Adjusting the display areas to the driving situation

You can select the three instruments that best fit your individual driving style and the driving situation.

WARNING

Driver distraction can cause accidents and injuries. Operating the Infotainment system can distract you from traffic.

- Always drive attentively and responsibly.

NOTICE





Avoid high engine speeds, full acceleration, and heavy engine loads after starting the engine when it is cold.

 Because of the methods that are used to determine power in the vehicle, the displayed values may not be completely precise.

Vehicle settings menu

You can switch individual functions and systems on and off and adjust settings in the vehicle settings menu in the Infotainment system.

Opening the Vehicle settings Menu

1. Switch the ignition on.
2. If necessary, switch on the Infotainment system.
3. Depending on the equipment, press the  button or function key and select the Vehicle menu.
 - Or: depending on the design, press the  button or function key and select the Settings menu.
 - Or: Tap the  function key and select the Car menu.
4. To open other menus in the Vehicle settings menu or to adjust settings to the menu items, tap the  function key and select the relevant function keys.
5. Tap the  function key to return to the previous menu.

A check mark  indicates that the respective function is switched on.

System settings and vehicle information display

- Vehicle settings (setup)
- Depending on the vehicle equipment: Think Blue. Trainer.
- Depending on vehicle equipment: Performance monitor ⇒ [Performance monitor](#).
- Depending on vehicle equipment: Lap timer ⇒ [Infotainment system lap timer](#).
- Volkswagen Digital Cockpit (Pro) ⇒ [Volkswagen Digital Cockpit Pro](#), ⇒ [Volkswagen Digital Cockpit Pro Information Displays](#).
- Active media.
- Driving Data.
- Vehicle status.
- Radio station selection.

 After starting the engine when the 12 V vehicle battery is severely drained or has been replaced or jump-started, system settings, e.g. personal convenience settings and programming, may be adjusted or deleted. Check and correct the settings after the 12 V vehicle battery is sufficiently recharged.

WARNING

Driver distraction can cause accidents and injuries. Operating the Infotainment system can distract you from traffic.

- Always drive attentively and responsibly.

Dynamic Road Sign Display

Introduction

The Dynamic Road Sign Display detects standard road signs using a camera in the interior rearview mirror base and informs the driver of detected speed limits and passing restrictions. Within the system limits, the system also displays an additional sign to indicate special restrictions. The system may also continue to display the valid speed limit on roads without signs.

The traffic signs recorded by the Dynamic Road Sign Display are shown in the display of the Volkswagen Digital Cockpit. Depending on the Infotainment system installed in the vehicle, the road signs may also be displayed there.

Dynamic Road Sign Display is always active when the ignition is started.

Road sign display

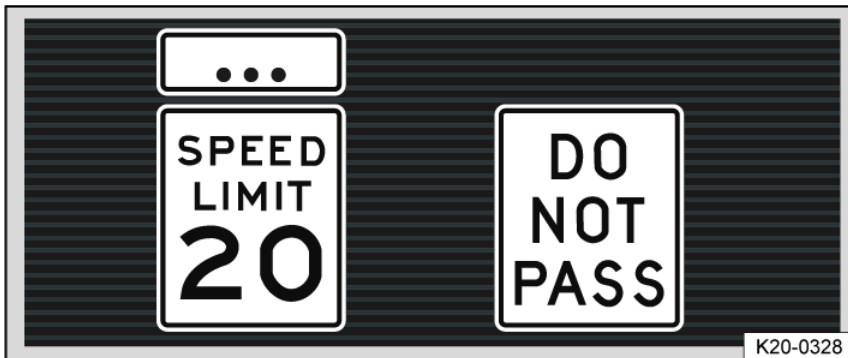

Fig. 17 In the instrument cluster display: Example of detected speed limits.

After checking and evaluating the information from the camera, the Infotainment system, and the current vehicle data, the Dynamic Road Sign Display function displays up to two valid traffic signs and a generic additional sign *fig. 17*:

1st position: The traffic sign that currently applies is shown on the left side of the display, for example a speed limit of 20 mph (35 km/h).

2nd position: Another road sign can be displayed in the second position, such as a passing restriction.

Additional signs: A recognized additional sign is displayed above the applicable traffic sign. Depending on the system, a generic additional sign is displayed instead of the actually recognized additional sign. The applicable traffic sign in the display of the instrument cluster is supplemented by the generic additional sign.

WARNING

The intelligent technology of the Dynamic Road Sign Display cannot overcome the natural laws of physics, and it can only operate within the limits of the system. Do not allow the increased convenience provided by the Dynamic Road Sign Display to tempt you into taking risks. The system cannot replace the driver's attention.

- Always adapt your speed and driving style to the visibility, weather, road and traffic conditions.
- Poor visibility, darkness, snowfall, rain, and fog may prevent road signs from being display or may cause them to be displayed incorrectly by the system.
- If the camera lens is dirty, obstructed, or damaged, the Dynamic Road Sign Display function may be limited.

WARNING

Driving recommendations and road signs displayed in the Dynamic Road Sign Display may differ from the actual traffic situation.

- Not all road signs can be detected and displayed correctly by the system.
- Traffic signs on the roads and traffic regulations must always take precedence over driving recommendations and displays from the Dynamic Road Sign Display function.

Limits of the Dynamic Road Sign Display

Please read the introductory information and heed the Warnings and Notice ⇒ *Introduction*.

Error messages

No road signs available. The system is in the initialization phase.

Or: the vehicle has not detected any road signs.

Error: Dynamic Road Sign Display. System malfunction. If the malfunction persists, contact a suitably qualified professional. Volkswagen recommends contacting an authorized Volkswagen dealer or authorized Volkswagen Service Facility.

Speed Alert currently not available. The speed alert from the Dynamic Road Sign Display is malfunctioning. If the malfunction persists, contact a suitably qualified professional. Volkswagen recommends contacting an authorized Volkswagen dealer or authorized Volkswagen Service Facility.

Dynamic Road Sign Display: Clean windshield! The windshield is dirty in the area around the camera or weather conditions are interfering with the camera view. Clean the windshield.

Dynamic Road Sign Display is currently limited. Data is not being transmitted by the Infotainment system. Check that valid map data is loaded in the Infotainment system.

Or: the vehicle is located in an area that is not detected on the map stored in the Infotainment system.

No data available. The Dynamic Road Sign Display function is not supported in the country where the vehicle is currently being operated.

Functional limitations

The Dynamic Road Sign Display is subject to system limitations. The following conditions may cause the Dynamic Road Sign Display function to be limited or to not operate at all:

- High ambient temperature or long exposure to direct sunlight.
- Poor visibility, such as in snow.
- Glare, for example from oncoming traffic or the sun
- High speeds
- If the camera is obstructed or dirty
- If road signs are outside of the camera's visual field
- If road signs are partially or completely covered, for example by trees, snow, dirt, or other vehicles.
- If road signs are not in the standard format
- If there are damaged or bent road signs
- If there are variable traffic signs on overhead signs (variable display of road signs by LEDs or other lighting).
- If there is outdated map material in the Infotainment system
- If there are stickers on vehicles that indicate road signs, such as speed limits on commercial vehicles

Operating the Dynamic Road Sign Display

 Please read the introductory information and heed the Warnings and Notice ⇒  [Introduction](#).

Speed warning

If the Dynamic Road Sign Display function detects that a valid speed limit is being exceeded, it may warn the driver audibly, or visually and audibly, with a message in the instrument cluster display.

The speed warning can be set or completely deactivated in the Infotainment system ⇒ [Vehicle settings menu](#). The speed warning can be set to a value of 0 mph (0 km/h), 3 mph (5 km/h) or 5 mph (10 km/h) over the permitted speed.

Trailer mode

On vehicles with a trailer hitch installed at the factory and a trailer that is connected to the vehicle electrical system, the display of road signs relevant to a trailer, such as the valid speed limit and passing restrictions for vehicles with a trailer, can be activated and deactivated in the vehicle settings in the Infotainment system ⇒ [Vehicle settings menu](#).

For trailer mode, the display of valid speed limits can be adjusted to the model of the trailer and to the legal regulations. The setting can be set in increments of 10 km/h (5 mph) within a range of approx. 60 km/h (35 mph) and approx. 130 km/h (80 mph). If a speed is set that is higher than the permitted speed for driving with a trailer in the country or state where the vehicle is being operated, the Dynamic Road Sign Display function will automatically display the legal speed limit, for example approx. 80 km/h (50 mph) in California.

Safety

General information

Driving preparations and driving safety

Observe the following points before and during every trip, for your own safety and for the safety of your passengers and others on the road ⇒ :

- ✓ Make sure the vehicle lighting and turn signals are functioning correctly.
- ✓ Check the tire pressure and fuel level ⇒ *Tire pressure*, ⇒ *Fuel gauge*.
- ✓ Check the washer fluid level ⇒ *Washer fluid*.
- ✓ Ensure that the windows are clear and provide good visibility ⇒ *Exterior care and cleaning*.
- ✓ The air intake for the engine must not be blocked. The engine must not be covered with covers or insulation ⇒ *Safety precautions for working in the engine compartment*.
- ✓ Secure all objects and luggage in the storage compartments and the luggage compartment ⇒ *Transporting*.
- ✓ It must be possible to press the pedals without interference.
- ✓ Secure children with child restraint systems that are appropriate for their weight and height ⇒ *Transporting children safely*.
- ✓ Adjust the front seats, head restraints, and mirrors according to the size of the occupants ⇒ *Seating position*, ⇒ *Mirrors*.
- ✓ Wear shoes that give your feet good grip for operating the pedals.
- ✓ The floor mat in the driver side footwell must be kept clear from the pedal area and be secured.
- ✓ Assume the correct seating position before driving and remain that way while driving. This also applies to all passengers ⇒ *Seating position*.
- ✓ Fasten the safety belt correctly before you begin driving and keep it fastened while driving. This also applies to all passengers ⇒ *Safety belts*.
- ✓ The number of passengers must not exceed the number of seats and safety belts.
- ✓ Never drive when impaired, for example by medication, alcohol, or drugs.
- ✓ Never allow yourself to be distracted from traffic, like by adjusting settings, by opening menus, by passengers, or by phone calls.
- ✓ Always adapt your speed and driving style to the current visual, weather, road, and traffic conditions.
- ✓ Follow driving rules and posted speed limits.
- ✓ Take regular breaks on long trips. You should take a break at least every two hours.
- ✓ Secure animals in the vehicle restraint systems that are appropriate for their weight and size.

Driving in other countries

Some countries have special safety standards and regulations that differ from the vehicle configuration. Volkswagen recommends that you inform yourself about legal regulations and about the following points from an authorized Volkswagen dealer or authorized Volkswagen Service Facility before driving in other countries.

Volkswagen recommends contacting an authorized Volkswagen dealer or authorized Volkswagen Service Facility.

- ✓ Do technical modifications need to be made to the vehicle before driving in other countries, such as covering or adjusting the headlights?
- ✓ Are the tools, diagnostic equipment, and replacement parts that are needed for maintenance and repair work available?
- ✓ Is there an authorized Volkswagen dealer or authorized Volkswagen Service Facility in the country where you will be driving?
- ✓ Are fluids that meet Volkswagen specifications available in the country where you will be driving ⇒ *Operating fluids and operating equipment?*
- ✓ Will the navigation function in the factory-installed Infotainment system work with the existing navigation data in the country where you will be driving?
- ✓ Are special tires needed in the country where you will be driving?
- ✓ Is a fire extinguisher required in the country where you will be driving?
- ✓ What are the requirements for a safety vest?
- ✓ Is fuel with sufficient quality available ⇒ *Fuel and emissions control system?*

Checks when refueling

Only perform work on the engine and in the engine compartment if you are familiar with the necessary steps and the general safety precautions, and if the correct operating equipment, fluids, and suitable tools are available ⇒ *Safety precautions for working in the engine compartment!* Have all work performed by suitably qualified professionals. Volkswagen recommends contacting an authorized Volkswagen dealer or authorized Volkswagen Service Facility. Make sure that the following items are checked regularly:

- ✓ Washer fluid level ⇒ *Washer fluid*.
- ✓ Engine oil level ⇒ *Engine oil*.
- ✓ Engine coolant level ⇒ *Engine coolant*.
- ✓ Brake fluid level ⇒ *Brake fluid specifications*.
- ✓ Tire inflation pressure ⇒ *Tire pressure*.

- ✓ Vehicle lighting ⇒ *Headlights* which is necessary for traffic safety:

Information on changing bulbs ⇒ *Exterior lighting*.

DANGER

Read and heed the important safety information for the front passenger's front airbag ⇒ *Safety notes on using child restraints*.

WARNING

Driving under the influence of alcohol, drugs, medication, and prescription narcotics can cause serious accidents and fatal injuries.

- Alcohol, drugs, medication, and prescription narcotics can considerably impair perception, reaction times, and driving safety, which can result in loss of vehicle control.

WARNING

Always heed the applicable driving regulations and speed limits and drive proactively. Evaluating driving situations correctly can make the difference between safely reaching your destination and being involved in a collision with serious injuries.

NOTICE

Volkswagen is not responsible for damage to the vehicle caused by substandard fuel, insufficient maintenance, or unsuitable replacement parts. Volkswagen recommends the use of Volkswagen original parts or Volkswagen original accessories, which you can acquire from an authorized Volkswagen dealer or authorized Volkswagen Service Facility.

 **Having the vehicle serviced regularly not only maintains the value of the vehicle, but also contributes to operational safety and roadworthiness. Therefore, have maintenance procedures performed according to Volkswagen instructions. Under extreme operating conditions, some work may need to be performed before the next service is due. Extreme operating conditions can include frequent stop-and-go driving or driving in areas with a lot of dust in the air. For further information, contact an authorized Volkswagen dealer or authorized Volkswagen Service Facility. Volkswagen recommends contacting an authorized Volkswagen dealer or authorized Volkswagen Service Facility.**

Seating position

Introduction

Number of seats

The vehicle has a total of five seats: two seats in the front and three seats in the back.

Every seat is equipped with a safety belt.

WARNING

Sitting incorrectly in the vehicle can increase the risk of serious or fatal injuries during sudden driving or braking maneuvers, in the event of a collision or accident, and if the airbags are deployed.

- Before the vehicle starts to move, all vehicle occupants must always be in the correct seating position and maintain it while driving. Safety belts must also be fastened and remain fastened.
- The number of persons in the vehicle must not exceed the number of seats with safety belts.
- Always secure children in the vehicle with an approved and suitable child restraint system according to the child's body size and weight ⇒ *Transporting children safely* and ⇒ *Airbag system*.
- Always keep feet in the footwell while driving. For example, never rest feet on the seat or on the instrument panel and never hold feet out of the window. Otherwise, if the airbag and the safety belt deploy, they could increase the risk of injury in the event of an accident instead of providing protection.

Risk of injury due to an incorrect seating position

 **Please read the introductory information and heed the Warnings and Notice ⇒  *Introduction*.**

The risk of serious or fatal injuries will increase if safety belts are not worn or are incorrectly fastened. Safety belts can only achieve the optimum protection if they are routed correctly. An incorrect seating position significantly impairs the protective function of the safety belt. This could result in serious or fatal injuries. The risk of serious or fatal injuries increases even more if a deployed airbag strikes a passenger who is sitting in an incorrect seating position. The driver is responsible for all vehicle occupants and especially for children who are being transported in the vehicle.

The following list includes examples of seating positions that could be dangerous for all vehicle occupants.

The following points always apply when the vehicle is in motion:

- Never stand inside the vehicle.

- Never stand on the seats.
- Never kneel on the seats.
- Never tilt your seat backrest too far back.
- Never lean against the instrument panel.
- Never lay down in the seats in the vehicle interior or on the rear bench seat.
- Never sit only on the front section of the seat.
- Never sit sideways on the seat.
- Never lean against the window.
- Never place your feet out of the window.
- Never place your feet on the instrument panel.
- Never place your feet on the seat cushion or on the seat backrest.
- Never ride in the footwell.
- Never sit on the armrests.
- Never drive or ride in a seat without fastening your safety belt.
- Never ride in the trunk.

⚠ WARNING

Incorrect seating positions in the vehicle increase the risk of serious or fatal injuries in the event of an accident or sudden driving and braking maneuvers.

- All vehicle occupants must always sit in the correct seating position and have their own safety belts correctly fastened while driving.
- Incorrect seating positions, failure to wear a safety belt, or being too close to an airbag increases the risk of serious injury or death to vehicle occupants, especially if the airbags deploy and come into contact with occupants who are not seated correctly.

Correct seating position

📖 Please read the introductory information and heed the Warnings and Notice ⇒ ⚠ Introduction.



Fig. 18 General example: correct distance between the driver and the steering wheel, correct safety belt routing and correct head restraint adjustment.

The correct seating positions for the driver and passengers are specified in the information that follows. The safety belt and airbags only provide the optimum protection when vehicle occupants are seated in a correct seating position.

If you have a physical impairment that prevents you from sitting correctly on the driver seat with a correctly worn safety belt and reaching the pedals, special modifications to your vehicle may be necessary. For information on possible changes to your vehicle, contact an authorized Volkswagen dealer or authorized Volkswagen Service Facility qualified for this. Volkswagen recommends contacting an authorized Volkswagen dealer or authorized Volkswagen Service Facility. Alternatively, contact the Volkswagen Customer CARE Center at +00 (1) 800 822 8987.

For your safety and to reduce the risk of injuries in the event of a sudden braking maneuver or accident, Volkswagen recommends the following seating positions:

The following applies to all vehicle occupants:

- Adjust the head restraint so that the upper edge of the head restraint is in line with the upper portion of the head as much as possible, but not lower than eye level. Position the back of the head as close as possible to the head restraint *fig. 18*.
- For shorter individuals, slide the head restraint all the way downward, even if the head is then below the upper edge of the head restraint.
- For taller individuals, move the head restraint upward all the way.
- Keep both feet in the footwell while driving.

- Adjust and fasten the safety belts correctly ⇒ *Safety belts*.

The following additional points apply to the driver:

- In vehicles with head restraints that can be moved forward or back, position the head restraint so that it is as close as possible to the back of the head.
- Adjust the steering wheel so that the distance between the steering wheel and your chest is at least 25 cm (around 10 inches) *fig. 18* and you can hold the steering wheel firmly at the sides with both hands and your elbows slightly bent.
- When adjusted, the steering wheel must always face your chest and not be directed toward your face.
- Position the seat backrest in an upright position, so that your back rests completely on the seat backrest.
- Adjust the forward/back position of the driver seat so that you can press the pedals while your legs are slightly bent and there is at least 10 cm (around 4 inches) of space between the instrument panel and your knees *fig. 18*.
- Adjust the driver seat so that the top point of the steering wheel can be reached.
- Always keep both feet in the footwell to keep control of the vehicle at all times.

The following additional points apply to the front passenger:

- In vehicles with head restraints that can be moved forward or back, position the head restraint so that it is as close as possible to the back of the head.
- Position the seat backrest in an upright position, so that your back rests completely on the seat backrest.
- Move the front passenger seat back as far as possible so that the airbag can provide optimum protection if it deploys.

Safety belts

Introduction

Check the condition of all of the safety belts regularly. If there is damage to the belt fabric, the belt connections, the retractor or the buckle, have the affected safety belt replaced immediately by an authorized Volkswagen dealer or authorized Volkswagen Service Facility ⇒ . The authorized Volkswagen dealer or authorized Volkswagen Service Facility must use the correct parts for the vehicle, equipment and model year. Volkswagen recommends contacting an authorized Volkswagen dealer or authorized Volkswagen Service Facility.

WARNING

The risk of serious and fatal injuries increases if the safety belts are not worn or are worn incorrectly. The optimum protection is only achieved if the safety belts are worn and used correctly.

- Safety belts are the most effective way to reduce the risk of serious and fatal injuries in a collision. To protect the driver and passengers, the safety belts must always be worn correctly when the vehicle is in motion.
- Before every trip, everyone in the vehicle must seat themselves correctly, fasten the safety belt that belongs to the seat they are using, and keep it fastened while the vehicle is in motion. This applies to all passengers and at all times, including during city driving.
- Secure children in the vehicle with a child restraint that is appropriate for their weight and height and with the safety belt used correctly ⇒ *Transporting children safely*.
- Only begin driving once all passengers are wearing their safety belts correctly.
- Only ever insert and latch the buckle tongue in the belt buckle for the corresponding seat. Using a buckle from another seat reduces the protection provided by the safety belt and can cause serious injuries.
- Never allow foreign objects or fluid to enter the openings in the belt buckles. This could impair the function of the belt buckles and safety belts.
- Never unfasten the safety belt while the vehicle is in motion.
- Secure only one person with a safety belt.
- Never allow children or infants to ride on anyone's lap and never strap children or infants to another person with the same safety belt.
- Do not wear extremely bulky, loose clothing in the vehicle, such as a coat over a sports jacket, because this could impair the fit and function of the safety belt.

WARNING

Damaged safety belts create a serious risk and can cause serious or fatal injuries.

- Never allow safety belts to become caught in the door or the seat mechanisms because the belts could be damaged.
- If the belt webbing or other parts of the safety belt are damaged, the safety belts could tear during a collision or sudden braking maneuver.
- Have damaged safety belts replaced immediately with new safety belts that are approved for the vehicle by Volkswagen. Safety belts that are stretched during a collision must be replaced by an authorized Volkswagen dealer or authorized Volkswagen Service Facility. Volkswagen recommends contacting an authorized Volkswagen dealer or authorized Volkswagen Service Facility. It may be necessary to replace them even if there is no visible damage. Check the safety belts' anchorage points as well.
- Never try to repair, modify, or remove the safety belts yourself. Have all repairs to safety belts, safety belt retractors, and buckle components performed

only by an authorized Volkswagen dealer or authorized Volkswagen Service Facility. Volkswagen recommends contacting an authorized Volkswagen dealer or authorized Volkswagen Service Facility.

Fasten seat belts reminder and seat belt safety indicator

📖 Please read the introductory information and heed the Warnings and Notice ⇒ ⚠️ *Introduction.*



Fig. 19 In the instrument cluster display: warning light.

⚠️ **The driver or front passenger has not fastened their safety belt. Fasten all safety belts.**

When the ignition is switched on, several warning and indicator lamps light up temporarily as a function check. They then turn off after a few seconds.

A chime also sounds.

When the ignition is switched on, the red ⚠️ warning light comes on for six seconds. A chime also sounds for up to six seconds if the driver safety belt is not fastened. The chime ends when the driver fastens their safety belt. The warning lamps and chime go off when the driver and front passenger have fastened their safety belts.

If the driver and front passenger do not both fasten their safety belts within 10 seconds after the warning chime has ended and the vehicle is driving at a speed above approx. 15 mph (approx. 25 km/h), the chime sounds again for approx. 6 seconds, then stops for approx. 24 seconds, and then sounds again for approx. 6 seconds. The same happens if one of the safety belts is released while driving. The red ⚠️ warning light comes on. A warning chime also sounds for up to two minutes at 24-second intervals. The chime does not sound at speeds below approx. 5 mph (approx. 8 km/h).

When the ignition is switched on, the red ⚠️ warning light comes on until the driver and front passenger have both fastened their safety belts.

⚠️ WARNING

The risk of serious and fatal injuries increases if the safety belts are not worn or are worn incorrectly. The optimum protection is only achieved if the safety belts are worn and used correctly.

Using safety belts

📖 Please read the introductory information and heed the Warnings and Notice ⇒ ⚠️ *Introduction.*

Checklist

Using safety belts → ⚠️:

- ✓ Check the condition of all of the safety belts regularly.
- ✓ Keep safety belts clean.
- ✓ Always keep foreign objects and fluids far away from the safety belt, the safety belt buckle, and the slot in the safety belt buckle.
- ✓ Do not pinch or damage the safety belt and/or belt buckle, for example closing it in a door.
- ✓ Never remove, modify, or repair the safety belt and belt fastening elements.
- ✓ Always fasten the safety belt correctly before you begin driving and keep it fastened while driving.

Twisted safety belt

If the safety belt is difficult to pull out of the belt guide, the safety belt may have been pulled out too quickly when positioning the belt and may have become twisted within the side trim panel:

1. Slowly and carefully pull the safety belt out completely by the belt buckle.
2. Untwist any twisted sections of the safety belt and guide the belt back slowly by hand.

If you cannot untwist the safety belt, fasten the safety belt anyway. The twist must not be in a section of the belt that rests directly on the body. Go to an authorized Volkswagen dealer or authorized Volkswagen Service Facility immediately to have the belt untwisted. Volkswagen recommends contacting an authorized

Volkswagen dealer or authorized Volkswagen Service Facility.

Lockable safety belt

The safety belts on the rear seats and the safety belt on the front passenger seat are lockable and have an emergency locking function. With the locking function, you can adjust the safety belt so that a child restraint is properly installed ⇒ [Securing a child restraint with a safety belt](#) .

Safety belts may only be locked for certain child restraint systems ⇒ [Child restraints – overview](#) .

An activated locking mechanism must be released when a vehicle occupant fastens their safety belt. To release the locking mechanism, push the red button in the belt buckle and guide the belt back fully by hand.

⚠ WARNING

Incorrect handling of the safety belts increases the risk of severe or fatal injuries.

- Check the safety belts and associated components regularly to ensure they function correctly.
- Safety belts cannot be repaired; they must be replaced.
- Always keep the safety belts clean.
- Do not pinch or damage the safety belt or allow it to rub against any objects with sharp edges.
- Always keep the belt buckle and insertion guide for the belt buckle free of foreign objects and fluids.

Fastening and unfastening the safety belts

📖 Please read the introductory information and heed the Warnings and Notice ⇒ ⚠ [Introduction](#) .

Safety belts that are fastened correctly hold vehicle occupants in the correct position during braking maneuvers or in a collision, in order to provide the maximum protection ⇒ ⚠ .

Fastening the safety belt



Fig. 20 Inserting the buckle tongue into the safety belt buckle.

Always fasten the safety belts before driving.

1. Adjust the front seat and head restraint correctly ⇒ [Seating position](#) .
2. Have the rear seat backrest locked into place in an upright position ⇒ ⚠ .
3. Grab the belt and pull it evenly over the chest and pelvis. Do not twist the belt while doing this ⇒ ⚠ .
4. Insert the buckle tongue securely in the safety belt buckle for that seat [fig. 20](#) .
5. Pull on the safety belt to make sure the buckle tongue is latched correctly in the safety belt buckle.

Unfastening the safety belt



Fig. 21 Releasing the buckle tongue from the safety belt buckle.

Only unfasten the safety belt while the vehicle is stationary ⇒ ⚠.

1. Press the red button in the safety belt buckle *fig. 21*.

The buckle tongue will pop out.

2. Guide the belt back by hand so that the belt rolls up easily, the belt does not twist, and the trim panel is not damaged.

⚠ WARNING

Incorrect belt routing can cause serious or fatal injuries in the event of an accident.

- Optimum protection from the safety belts is only possible when the backrest is in an upright position and the safety belts are worn correctly according to the body size of the passenger.
- Unfastening the safety belt while driving can lead to serious or fatal injuries in the event of an accident or braking maneuver.

Safety belt positioning

📖 Please read the introductory information and heed the Warnings and Notice ⇒ ⚠ Introduction.

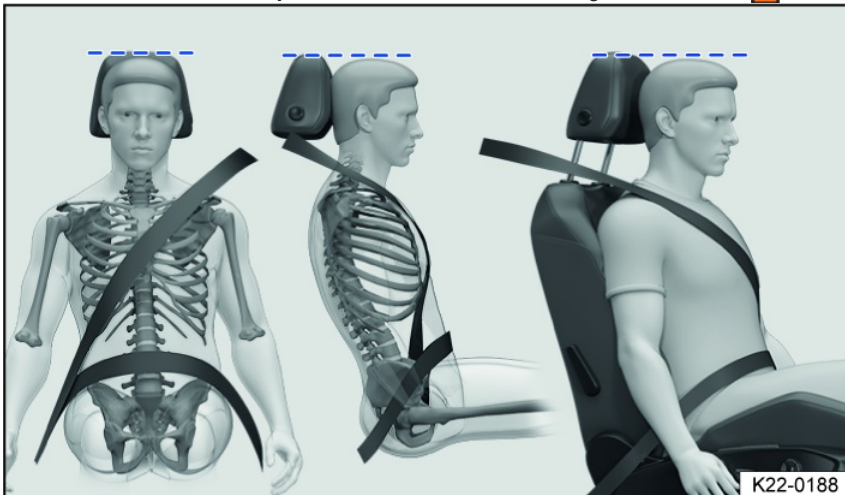

Fig. 22 Correct safety belt positioning and correct head restraint adjustment.

Safety belts only offer the optimum protection during a collision and reduce the risk of serious injury or death if they are fastened and positioned correctly. The correct safety belt position also holds the vehicle occupant in place so that the airbags can provide their maximum protection if they deploy. Therefore, all vehicle occupants should always fasten their own safety belts and make sure they are positioned correctly *fig. 22*.

An incorrect seating position can cause severe or fatal injuries ⇒ *Seating position*.

Correct safety belt positioning

- The shoulder belt section of the safety belt must always be positioned over the center of the shoulder and never across the neck, above the arm, under the arm, or behind the back.
- The lap section of the safety belt must always lie across the lap and never over the stomach.
- The safety belt must always rest flat and securely on the body. Retighten the belt if necessary.

Correct safety belt positioning for pregnant women



Fig. 23 Correct safety belt positioning for pregnant women.

For pregnant women, the safety belt must rest evenly across the chest and as low and flat as possible on the lap, so that no pressure is applied to the lower abdomen. This should be done throughout the entire pregnancy *fig. 23*.

Adjusting the safety belt position to body size

The belt positioning can be adjusted with the following equipment:

- Belt height adjusters for the front seats ⇒ *Safety belt height adjuster*.
- Height-adjustable front seats ⇒ *Seating position*.

⚠ WARNING

Incorrect safety belt positioning can cause serious injuries in the event of an accident or during sudden braking or driving maneuvers.

- Optimum protection from the safety belts is only possible when the backrest is in an upright position and the safety belts are worn correctly.
- The safety belt itself or a loose safety belt can cause serious injuries if it shifts onto soft areas of the body, such as the stomach.
- The shoulder portion of the safety belt must lie over the center of the shoulder, and never under the arm or across the neck.
- The safety belt must lie flat and securely on the upper part of the body.
- The lap section of the safety belt must lie across the lap and never over the stomach. The safety belt must lie flat and securely on the lap. Retighten the belt if necessary.
- The lap belt section of the safety belt must sit as low as possible on the lap of pregnant women and lie flat under the “rounding” of the abdomen.
- Do not twist the safety belt while wearing it.
- Never hold the safety belt away from the body with your hand.
- Do not guide the safety belt over hard or breakable objects, such as eyeglasses, pens, or keys.
- Do not modify how the safety belt is routed using belt clips, retaining loops, or similar objects.

ⓘ Persons who cannot achieve the optimum belt routing due to physical conditions should contact an authorized Volkswagen dealer or authorized Volkswagen Service Facility about possible special modifications that can be used to achieve the best possible protection with the safety belt and airbags. Volkswagen recommends contacting an authorized Volkswagen dealer or authorized Volkswagen Service Facility.

Safety belt height adjuster



Fig. 24 Next to the front seats: safety belt height adjuster.

You can use the safety belt height adjuster to adjust the safety belt routing in the shoulder area according to your individual body size, so that the safety belt can be correctly fastened:

1. Push down and hold the safety belt height adjustment button in the direction of the arrows *fig. 24*.
2. Slide the safety belt height adjuster upward or downward until the safety belt lies over the center of the shoulder ⇒ *Safety belt positioning*.
3. Release the safety belt height adjustment button.
4. Pull hard on the safety belt to check that the safety belt height adjuster is engaged.

⚠️ WARNING

Never adjust the safety belt height while driving.

Automatic safety belt retractor, safety belt pretensioner, safety belt load limiter

The vehicle seat belts are part of the vehicle safety concept ⇒ *Airbag system*. The vehicle safety concept has the following key functions:

Automatic safety belt retractor

Every safety belt is equipped with an automatic safety belt retractor on the shoulder belt section. If the safety belt is pulled slowly or while driving normally, the shoulder belt will be able to move freely. The automatic safety belt retractor blocks the safety belt from moving if the safety belt is pulled out quickly, for example during sudden braking maneuvers, when driving on hills, when driving around curves and when accelerating.

Safety belt pretensioners

The safety belts for the driver and front seat passenger are equipped with safety belt pretensioners.

Safety belt pretensioners are activated by sensors and tighten the safety belts in the event of severe front-on, side and rear collisions or if the vehicle rolls over. If the safety belt is loose, it retracts. This can reduce the forward movement of the vehicle occupants and movement of the vehicle occupants in the direction of the collision. The safety belt pretensioner works together with the airbag system. The safety belt pretensioner is only activated during a rollover accident if the Side Curtain Protection® airbags are deployed.

Fine dust may appear if airbags deploy. This is completely normal and does not indicate a fire in the vehicle.

⚠️ WARNING

The safety belt pretensioners only provide protection for one deployment. If the safety belt pretensioners deploy, the system must be replaced.

- Have deployed safety belt pretensioners and affected system components replaced immediately with new parts that are approved by Volkswagen for the vehicle.
- Only have suitably qualified professionals make repairs or modifications to a vehicle. Authorized Volkswagen dealers and authorized Volkswagen Service Facilities have the required tools, diagnostic devices, repair information, and qualified personnel. Volkswagen recommends contacting an authorized Volkswagen dealer or authorized Volkswagen Service Facility.
- Never install safety belt pretensioner components removed from scrap vehicles or from recycling.
- Never modify any components of the safety belt pretensioners.

Safety belt load limiter

Safety belt load limiters reduce the force placed on the body by the safety belts during a collision.

 When disposing of the vehicle or of individual system components, all safety precautions must be observed. An authorized Volkswagen dealer or authorized Volkswagen Service Facility will be familiar with these provisions ⇒ *Safety belt pretensioner servicing and disposal*. Volkswagen recommends contacting an authorized Volkswagen dealer or authorized Volkswagen Service Facility.

Safety belt pretensioner servicing and disposal

 Please read the introductory information and heed the Warnings and Notice ⇒  *Introduction*.

When working on safety belt pretensioners, as well as when removing and installing other vehicle components as part of repair work, the safety belts can become damaged without you noticing. This may cause the safety belt pretensioner to function incorrectly or prevent it from functioning in the event of an accident.

The instructions must be followed so that the effectiveness of the safety belt pretensioner is not impaired and removed components do not cause injuries and environmental pollution. An authorized Volkswagen dealer or authorized Volkswagen Service Facility will be familiar with these provisions. Volkswagen recommends contacting an authorized Volkswagen dealer or authorized Volkswagen Service Facility.

WARNING

Repairs that you perform yourself or that are performed incorrectly on the safety belts, automatic safety belt retractors, and safety belt pretensioners can increase the risk of severe or fatal injuries. The safety belt pretensioner may not deploy when it should, or it may deploy unexpectedly.

- Never perform repairs, adjustments, or removal and installation of components of the safety belt pretensioners or safety belts yourself. Only have these procedures performed by suitably qualified professionals ⇒ *Accessories, replacement parts, repairs, and modifications*. Volkswagen recommends contacting an authorized Volkswagen dealer or authorized Volkswagen Service Facility.
- Safety belts, safety belt pretensioners and automatic safety belt retractors cannot be repaired. These components must be replaced.

 Some parts of the vehicle, such as the airbag module and safety belt pretensioners, may contain perchlorate. Special handling may be necessary. For further information, visit <https://dtsc.ca.gov/perchlorate>.

Airbag system

Introduction

The vehicle is equipped with a front airbag for the driver and one for the front passenger. The front airbags can offer additional protection for the chest and head of the driver and front passenger as long as the seat, the safety belt, the head restraint, and the steering wheel are adjusted and used correctly. Airbags are only designed to offer supplementary protection. Airbags are not a replacement for safety belts. Safety belts must always be worn, even if the front seats are fitted with front airbags.

WARNING

Never rely only on the airbag system for protection.

- Even when an airbag deploys, it only offers supplementary protection.
- The airbag system provides optimum protection when the safety belt is worn correctly and it reduces the risk of injury ⇒ *Safety belts*.
- Before every trip, everyone in the vehicle must seat themselves correctly, fasten the safety belt that belongs to the seat they are using, and keep it fastened while the vehicle is in motion. This applies to all passengers and at all times, including during city driving.

WARNING

Sitting too close to the steering wheel or the instrument panel reduces the effectiveness of the airbags and increases the risk of injury in the event of a collision.

- Adjust the driver seat so that there is a distance of at least 10 inches (25 cm) between your chest and the center of the steering wheel.
- Adjust the front passenger seat so that there is the greatest possible distance between the front passenger and the instrument panel.
- If body characteristics mean that this is not possible, see an authorized Volkswagen dealer or authorized Volkswagen Service Facility to have special modifications made. Volkswagen recommends contacting an authorized Volkswagen dealer or authorized Volkswagen Service Facility.
- If you have not fastened your safety belt correctly, if you lean forwards, sit sideways or are in any way seated outside the intended sitting position, the risk of you being injured is far higher.
- Make sure that your safety belt is fastened correctly to reduce the risk of injury if an airbag deploys.
- When using a rear-facing child restraint on the front passenger's seat, the risk of life-threatening or fatal injuries in the event of a collision increases for the child. Never use rear-facing child restraints on the front passenger's seat.
- Make sure that children under 12 years of age always sit on a rear seat. Children that are not correctly strapped in can suffer serious or even fatal injuries if the airbag deploys.

- Secure children in the vehicle with a child restraint that is appropriate for their weight and height and with the safety belt used correctly.
- Adjust the front seats correctly.
- Never drive with the backrest angled too far back or forward.
- Position the seat backrest in an upright position, so that your back rests completely on the seat backrest.
- Always keep feet in the footwell while driving. For example, never rest feet on the seat or on the instrument panel and never hold feet out of the window. Otherwise, if the airbag and the safety belt deploy, they could increase the risk of injury in the event of an accident instead of providing protection.

WARNING

The risk of injury if the airbag deploys increases if there are objects located between vehicle occupants and the airbag deployment zone. These objects could change the deployment zone of the airbag or could strike the vehicle occupants.

- Never hold objects in your hands or on your lap while driving.
- Never transport objects on the front passenger's seat. During sudden braking or driving maneuvers, the objects could move into the airbag deployment zone and then be thrown through the vehicle interior if the airbag deploys.
- There should be no people, animals, or objects between the occupants of the front seats or outer rear seats and the airbag deployment zone. Make sure that child and adult passengers also follow these instructions.

WARNING

The airbag system only provides protection for one deployment. If the airbags deploy, the system must be replaced.

- Have deployed airbags and affected system components replaced immediately with new parts approved by Volkswagen for the vehicle.
- Only have suitably qualified professionals make repairs or modifications to a vehicle. Suitably qualified professionals have the required tools, diagnostic devices, repair information, and qualified personnel. Volkswagen recommends contacting an authorized Volkswagen dealer or authorized Volkswagen Service Facility.
- Never install airbag components removed from scrap vehicles or from recycling.
- Never modify any components of the airbag system.

WARNING

Fine dust and water vapor can develop when the airbags deploy. This is normal and does not indicate a fire in the vehicle.

- The fine dust can irritate the skin and mucous membranes in the eyes and can cause breathing problems, particularly for individuals who have asthma or other respiratory conditions. To reduce the risk of breathing problems, exit the vehicle or open the windows or doors for fresh air.
- If you come into contact with the dust, wash your hands and face with mild soap and water before eating anything.
- Do not allow the dust to come into contact with your eyes or any open wounds.
- Flush your eyes with water if dust enters them.

WARNING

Cleaners that contain solvents can make the surface of the airbag module porous. Plastic pieces that come loose could cause serious injuries in the event of a collision with airbag deployment.

- Never treat the instrument panel and the surface of the airbag modules with cleaners that contain solvents.

Advanced Airbag System



 Please read the introductory information and heed the Warnings and Notice ⇒  Introduction.

Read and follow the introductory information and safety precautions ⇒ Safety notes on using child restraints.

An active passenger's front airbag presents serious dangers for a child → . For this reason, all children under the age of twelve must be secured in the rear seats while the vehicle is in motion.

The Advanced Airbag System, together with the side and Side Curtain Protection® airbags, is checked every time the ignition is switched on. The yellow airbag indicator light  comes on briefly and turns off after several seconds.

Features of the Advanced Airbag System:

- Front passenger's front airbag in the instrument panel
- Yellow indicator light  in the instrument cluster display.
- Yellow indicator light PASSENGER AIR BAG OFF .

If the status of the  indicator light is one of the following, the Advanced Airbag System must be checked by an authorized Volkswagen dealer or authorized Volkswagen Service Facility:

- The indicator light does not come on for several seconds when the ignition is switched on.
- The indicator light stays on after the ignition is switched on.
- The indicator light comes on or flashes again after it is turned off.
- The indicator light comes on while driving.

Advanced Airbag System, small children, child restraints and children on the front passenger seat

The Advanced Airbag System in your vehicle has been certified and complies with the regulations of the United States Federal Motor Vehicle Safety Standard (FMVSS) 213 and the Canada Motor Vehicle Safety Standard (CMVSS) 213 at the time of vehicle manufacture. In accordance with the requirements, the system on the passenger's side has been designed to "inhibit" deployment for small children of up to 12 months of age and "low-risk deployment" for children of between three and six years of age.

The airbag on the passenger's side is a potential danger for children when it is deployed. The front passenger seat is not the safest seat for a child in a forward-facing child restraint and is a very dangerous seat for a child or small child in a backward-facing child restraint.

The Advanced Airbag System has a capacitive detection system in the seat cushion of the front passenger seat which detects whether a baby, small child or child is in a child restraint on the front passenger seat.

The capacitive detection system measures the electrical capacity of a child, the child restraint and a child's blanket on the front passenger seat.

The electrical capacity of a child restraint depends on the child restraint type. Together with the average capacity values of small children and one-year-old children the capacity values of all child restraints specified in accordance with FMVSS 213 and CMVSS 213 are stored in the Advanced Airbag System control module. These are compared with the values detected. Only use child restraints that are specified according to these standards and have been approved by the child restraint manufacturer for use with airbag systems. The U.S. National Highway Traffic Safety Administration (NHTSA) has published a list of certified child restraint models for use with the Advanced Airbag System in accordance with FMVSS 208.

Only install child restraints on the front passenger seat under exceptional circumstances. Carefully read all of the information about child restraints and the Advanced Airbag System beforehand and follow all instructions and warnings. Make sure that the system has correctly detected the child restraint on the front passenger seat and the front passenger's front air bag has been switched off. The yellow **OFF**  PASSENGER AIR BAG indicator light will come on.

DANGER

The front passenger seat of a vehicle is a potential danger to children (even for advanced airbags). In the event that front passenger seat air bags are deployed, children who are completely unsecured in an unsecured child restraint or in a rear-facing child restraint on the front passenger seat will suffer serious or fatal injuries.

- Even if your vehicle is equipped with an Advanced Airbag System, make sure that children (particularly children younger than 12 years of age) are always transported in such a way that they are secured to the rear seats according to their age and size.

Indicator light for front passenger's front airbag

 Please read the introductory information and heed the Warnings and Notice   Introduction.

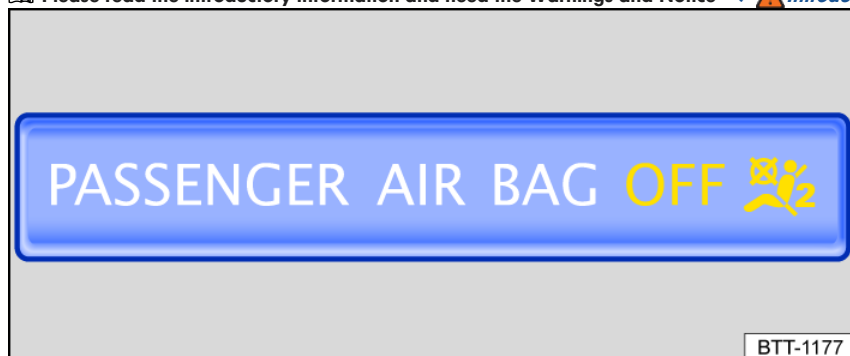



Fig. 25 In the instrument panel: Indicator light for the deactivated front passenger's front airbag.

The yellow PASSENGER AIR BAG indicator light **OFF**  comes on as soon as the Advanced Airbag System has deactivated the front passenger airbag.

If the yellow PASSENGER AIR BAG indicator light **OFF**  malfunctions, the yellow indicator light  appears in the instrument cluster to indicate a malfunction. Although a faulty indicator light does not affect the function of the front passenger's front airbag, the yellow PASSENGER AIR BAG indicator light **OFF**  can no longer be used to display the status of the front passenger's front airbag. Immediately visit an authorized Volkswagen dealer or authorized Volkswagen Service Facility to have the system checked. Volkswagen recommends contacting an authorized Volkswagen dealer or authorized Volkswagen Service Facility.

The yellow PASSENGER AIR BAG indicator light **OFF**  blinks for around five seconds in the following situations:

- The capacitive passenger detection system detects a change in the load on the front passenger seat.

After the yellow **OFF**  PASSENGER AIR BAG indicator light stops blinking, ensure that the status of the airbag (on or off) is shown correctly according to whether the seat is occupied. The indicator light remains on if the front passenger seat is unoccupied or the system has detected a child restraint that corresponds to FMVSS 208 or CMVSS 208 → page , *Airbag system*. The indicator light switches off if the seat is occupied by an adult.

The yellow PASSENGER AIR BAG indicator light **OFF**  must come on when the ignition is switched on and an infant carrier or child restraint is installed on the front passenger seat and the measured capacity is less than or equal to the capacity of an average one-year old child in a child restraint system as per FMVSS 208 or CMVSS 208.

If the front passenger seat is not occupied, the front passenger's front airbag is also deactivated and the indicator light remains on.

Never install a rear-facing child restraint on the front passenger seat. The safest place for a child restraint is on the rear seat.

Under these conditions, the yellow PASSENGER AIR BAG indicator light **OFF**  must come on permanently whenever the ignition is on. If this is not the case, stop the vehicle as soon as it is safe to do so and follow these instructions:

- Switch the ignition off for at least four seconds and then switch it on again.
- Remove the child restraint from the front passenger seat and install it again according to the manufacturer's instructions. When doing so, ensure that the child restraint is installed correctly.
- Ensure that the safety belt has been guided around the child restraint correctly and that it is secure.
- Ensure that there are no electronic devices on the front passenger seat.
- Ensure that the safety belt and belt buckle are working correctly and not blocked.
- Ensure that no seat heating or similar systems have been retrofitted.
- Ensure that there are no damp objects on the front passenger seat.

If the yellow PASSENGER AIR BAG indicator light **OFF**  still does not come on, remove the child restraint immediately and install it on the rear seat. Visit an authorized Volkswagen dealer or authorized Volkswagen Service Facility as soon as possible to have the airbag system checked. Volkswagen recommends contacting an authorized Volkswagen dealer or authorized Volkswagen Service Facility.

The yellow PASSENGER AIR BAG indicator light **OFF**  must not come on if the front passenger seat is occupied by an adult. However, if this is the case, stop the vehicle as soon as it is safe to do so and ensure the following:

- Ensure that the passenger is sitting in the middle of the seat and that the backrest is upright.
- Ensure that the belt is correctly positioned and tight.
- Ensure that there are no other objects on the seat cushion, such as blankets or booster seats, that could affect the system's ability to detect a passenger.

If the yellow PASSENGER AIR BAG indicator light **OFF**  is still permanently on, the passenger must move to the rear seat. Visit an authorized Volkswagen dealer or authorized Volkswagen Service Facility as soon as possible to have the airbag system checked. Volkswagen recommends contacting an authorized Volkswagen dealer or authorized Volkswagen Service Facility.

If the status of the Advanced Airbag System changes while driving, the yellow **OFF**  PASSENGER AIR BAG indicator light blinks for around five seconds. Stop the vehicle as soon as it is safe to do so and follow the instructions specified here.

If the system recognizes that the front passenger seat is unoccupied, the front passenger's front airbag remains deactivated and the yellow PASSENGER AIR BAG indicator light **OFF**  comes on continuously.

If the front passenger seat is unoccupied and the passenger's safety belt is fastened, the yellow PASSENGER AIR BAG indicator light **OFF**  also comes on permanently.

Troubleshooting

 Please read the introductory information and heed the Warnings and Notice ⇒  **Introduction.**

Airbag system or safety belt pretensioners malfunction

The yellow indicator light stays on. There may also be a message in the instrument cluster display.

A malfunction has been detected in at least one of the airbags or safety belt pretensioners.

1. Visit an authorized Volkswagen dealer or authorized Volkswagen Service Facility and have the airbag system and safety belt pretensioners checked. Volkswagen recommends contacting an authorized Volkswagen dealer or authorized Volkswagen Service Facility.

Airbag or safety belt pretensioner system deactivated with diagnostic equipment

After the ignition is switched on, the yellow indicator light turns on for about four seconds and then blinks for about twelve seconds. There may also be a message in the instrument cluster display.

At least one airbag or safety belt pretensioner has been switched off by a diagnostic device.

1. Have a suitably qualified professional check whether the airbag system or safety belt pretensioners need to remain switched off. Volkswagen recommends contacting an authorized Volkswagen dealer or authorized Volkswagen Service Facility.

OFF **Front passenger's front airbag switched off**

The yellow indicator light stays on.

The front passenger's front airbag is switched off.

1. Check whether the front passenger's front airbag has to be switched off.
2. If the front passenger's front airbag is incorrectly switched off, there may be a malfunction in the airbag system. Contact an authorized Volkswagen dealer or authorized Volkswagen Service Facility. Volkswagen recommends contacting an authorized Volkswagen dealer or authorized Volkswagen Service Facility.

Airbag description and function

 Please read the introductory information and heed the Warnings and Notice ⇒  Introduction.

The airbag can protect vehicle occupants in a collision by reducing the movement of vehicle occupants in the direction of the impact during frontal and side collisions.

The airbag is filled by a gas generator when it deploys. When this occurs, the airbag covers open and the airbags unfold with great force into their deployment zones within milliseconds. When vehicle occupants who are wearing safety belts sink into the airbags, the gas contained in the airbags is released in order to cushion the individuals and slow their movement. This can reduce the risk of serious and fatal injuries. The airbag cannot always prevent other injuries, such as swelling, bruises, burns, and abrasions. Heat from friction can develop when the airbag deploys.

Airbags do not provide any protection for arms and the lower part of the body.

The most important factors for triggering airbag deployment are the type of collision, the angle of impact, the vehicle speed, and the characteristics of the object with which the vehicle is colliding. Therefore, the airbags will not deploy in all situations where there is visible vehicle damage.



The deployment of the airbag system depends on the vehicle deceleration rate resulting from the impact, which is detected by an electronic control module. If the deceleration rate is below the minimum value programmed into the control module, then the airbags will not be deployed even though there may be significant vehicle damage. The extent of vehicle damage, the repair costs, or even the absence of vehicle damage in a collision are not indicators of whether the airbag should have deployed or not. Because situations can vary greatly among different collisions, it is not possible to define a range of vehicle speeds and reference values. Therefore, it is not possible to cover every conceivable type of impact and impact angle that could trigger airbag deployment. Among other things, important factors for airbag deployment include the characteristics of the object with which the vehicle collides (hard or soft), the angle of impact, and the vehicle speed.

Airbags are only a supplement to the three-point safety belts in some collisions when the deceleration of the vehicle is great enough to trigger airbag deployment. Airbags can only deploy once, and only under certain conditions. The safety belts are always there to provide protection in situations where the airbags do not deploy or if they have already deployed — for example, this may be the case if the vehicle collides with another vehicle or is hit by another vehicle after the initial impact.

The airbag system is part of the entire passive vehicle safety concept. The airbag system can only provide the best possible protection when it works in conjunction with safety belts that are fastened correctly and a correct seating position  ⇒ Seating position, ⇒ Safety belts.

Components of the vehicle safety concept

The vehicle safety concept is comprised of the following safety features in the vehicle that reduces the risk of serious and fatal injuries. Depending on vehicle equipment, some equipment may not be installed in the vehicle or may not be available in some countries.

- Optimized safety belts in all seating positions.
- Safety belt pretensioners for the driver and front passenger.
- Safety belt load limiters for the driver and front passenger.
- Belt height adjusters for the front seats.
- Red warning light .
- Front airbags for the driver and front passenger.
- Advanced Airbag System for the driver and front passenger.
- Capacitive passenger detection system for the front passenger's airbag.
- Side airbags for the driver and front passenger.
- Side Curtain Protection® for outer seats.
- Yellow airbag indicator light .
- Yellow PASSENGER AIR BAG indicator light **OFF**  in the center console.
- Control modules and sensors.
- Safety-optimized and height-adjustable head restraints.
- Adjustable steering column.
- Anchorage points for child restraints on the rear seats.
- Anchorage points for the top tether strap for child restraints.

How the components of the Advanced Airbag System work together:

On the passenger's side, regardless of whether the safety belt is being used or not, the front passenger's front airbag is switched off if the electrical capacity measured on the front passenger seat by the capacitive passenger detection system is smaller than the value saved in the control module. The front passenger's front airbag is also deactivated if the measured capacity corresponds to the value for an infant of around one year old in a child restraint certified by the Federal Motor Vehicle Safety Standard 208.

The indicator light for the front passenger's front airbag lights up continuously to tell you that the Advanced Airbag System on the front passenger side has been deactivated.



Situations where front airbags, side airbags or Side Curtain Protection® airbags do not deploy:

- If the ignition is switched off in a collision.
- Deceleration measured at the vehicle front end during the collision is too low for the control module.
- In minor side collisions.
- The dynamics measured by the control module during a rollover are too low.
- In rear collisions.
- If the collision speed is lower than the required reference value in the control module.

Components of the Advanced Airbag System

 Please read the introductory information and heed the Warnings and Notice ⇒  Introduction.

The following components are essential parts of the Advanced Airbag System:

- Capacitive passenger detection system in the front passenger seat.
- Optimized safety belts with safety belt pretensioners and safety belt load limiters.
- Front airbags for the driver and front passenger.
- Airbag indicator light .
- PASSENGER AIR BAG OFF  indicator light
- Control modules and sensors.

WARNING

Airbags and safety belt pretensioners that do not function properly can cause serious or fatal injuries in the event of an accident.

- If the airbag indicator light turns on, have the system inspected by an authorized Volkswagen dealer or authorized Volkswagen Service Facility as soon as possible. Volkswagen recommends contacting an authorized Volkswagen dealer or authorized Volkswagen Service Facility.
- Only use original Volkswagen replacement parts and have the installation performed by authorized specialists only.
- Never use used or recycled airbags or parts in the Advanced Airbag System. Only use new parts.

WARNING

Damage to the front passenger seat may affect the function of the Advanced Airbag System and cause severe or fatal injuries.

- Have damaged components in the front passenger seat and the capacitive detection system replaced by authorized specialists as soon as possible.
- Never remove the front passenger seat or components of the front passenger seat, such as seat surfaces, wires, lines or seat covers.
- Never damage the seat covers or the seat surface of the front passenger seat.
- Never use protective covers or seat surfaces on the front passenger seat as these affect the capacitive detection system.
- Never transport electronic or electrical objects on or under the front passenger seat as these affect the capacitive detection system.
- Never use protective covers, cushions or similar items on the front passenger seat as these affect the capacitive detection system.
- Never install seat heating on the front passenger seat.
- Never replace the seat cover on the front passenger seat.

WARNING

If the front passenger seat becomes wet or damp, this can cause the Advanced Airbag System to malfunction.

- Allow the seat to dry as soon as possible and check it for damage.

Front airbags

 Please read the introductory information and heed the Warnings and Notice ⇒  Introduction.

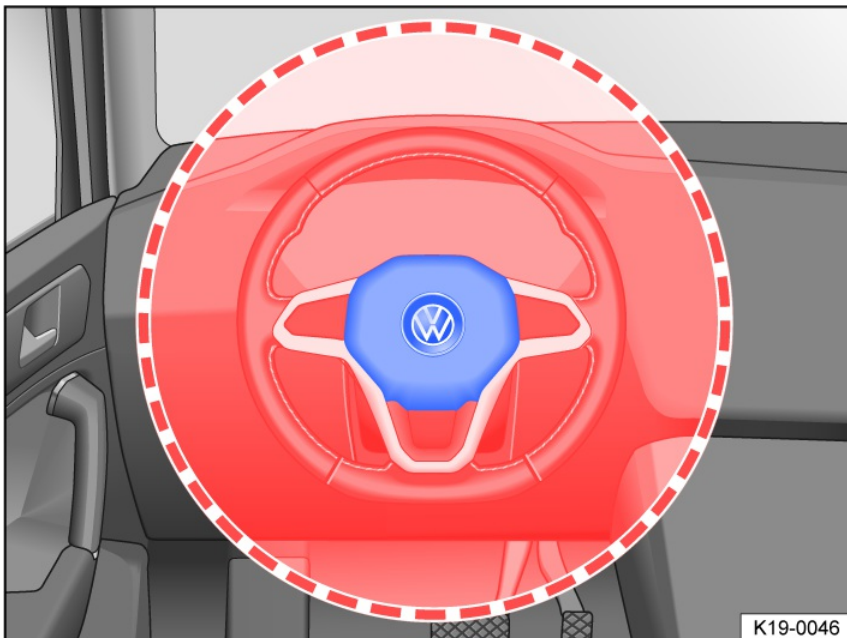

Fig. 26 Installation location and deployment zone of the driver's front airbag.

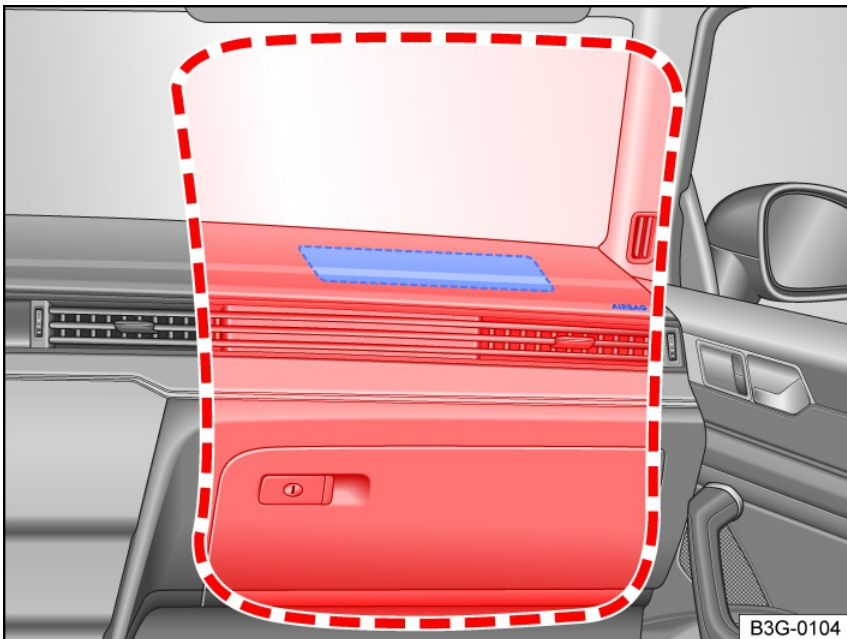

Fig. 27 Installation location and deployment zone of the front passenger's front airbag.

As a supplement to the safety belts, the front airbag system offers additional protection for the head and chest regions of the driver and front passenger during front collisions with higher impact severity. In certain head-on collisions, the Side Curtain Protection® airbags will also deploy on both sides.

Always maintain as much distance as possible to the front airbag ⇒ *Seating position*. This allows the front airbags to expand completely during collisions and thus provide maximum protection.

The front airbag for the driver is located in the steering wheel *fig. 26* and the front airbag for the front passenger is located in the instrument panel *fig. 27*. The airbag installation locations are marked with the lettering "AIRBAG".

The area outlined in red defines where the front airbags will deploy (deployment zone). Therefore, never place or attach objects in these areas ⇒ ⚠. The attachments mounted at the factory will not be affected by the deployed driver's and front passenger's front airbag.

The front airbags do not deploy in the following situations:

- In case of crashes when the ignition is switched off.
- In side-on collisions.
- In case of a rear-end collision.
- If the vehicle rolls over.
- If the impact speed is too low.

The front passenger's front airbags do not deploy in the following situations:

- If the front passenger seat is not occupied.
- If the passenger seat recognition system recognizes that the front passenger seat is unoccupied and the PASSENGER AIR BAG OFF  indicator light comes

on.

⚠ DANGER

An airbag deploys within a few milliseconds and at a very high speed.

- Always keep the deployment zones of the front airbags clear.
- Never attach objects to the covers or in the deployment zone of the airbag module, such as cup holders or phone holders.
- There should be no people, animals, or objects between the occupants of the front seats and the airbag deployment zone. Make sure that children and passengers also follow this guideline.
- Do not attach any objects, such as mobile navigation systems, to the windshield above the front airbag on the passenger's side.
- Do not tape over or cover the steering wheel airbag module or the surface of the instrument panel in the deployment zone of the front passenger's front airbag, or modify them in any other way.

⚠ WARNING

The front airbags expand in front of the steering wheel [fig. 26](#) and the instrument panel [fig. 27](#).

- Always hold the steering wheel with both hands on the sides of the outer edge, in the nine o'clock and three o'clock position.
- Adjust the driver seat so that there is a distance of at least 10 inches (25 cm) between your chest and the center of the steering wheel. If body characteristics mean that this is not possible, you must contact an authorized Volkswagen dealer or authorized Volkswagen Service Facility. Volkswagen recommends contacting an authorized Volkswagen dealer or authorized Volkswagen Service Facility.
- Adjust the front passenger seat so that there is the greatest possible distance between the front passenger and the instrument panel.

Side airbags

 Please read the introductory information and heed the Warnings and Notice  [Introduction](#).

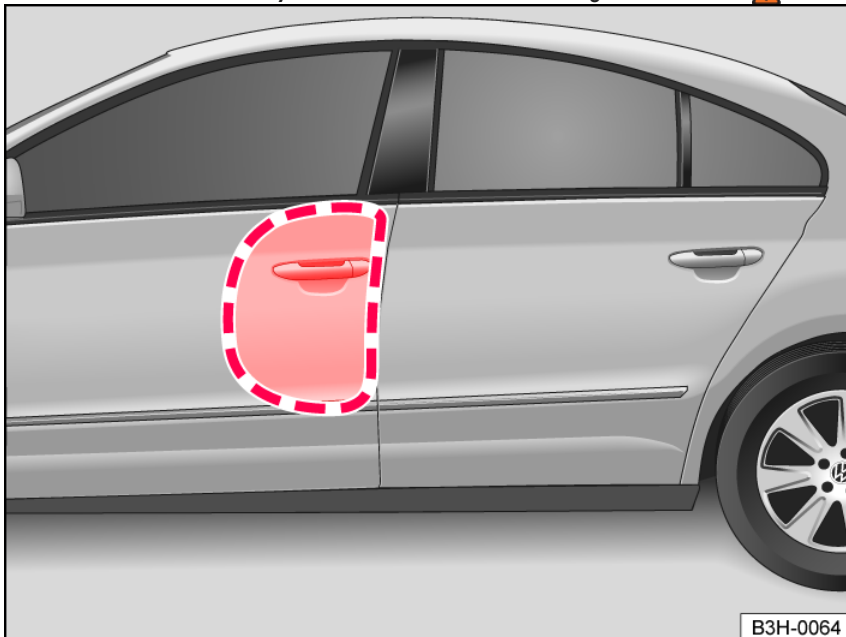

Fig. 28 In the vehicle interior on the left-hand side: Side airbag deployment zone.

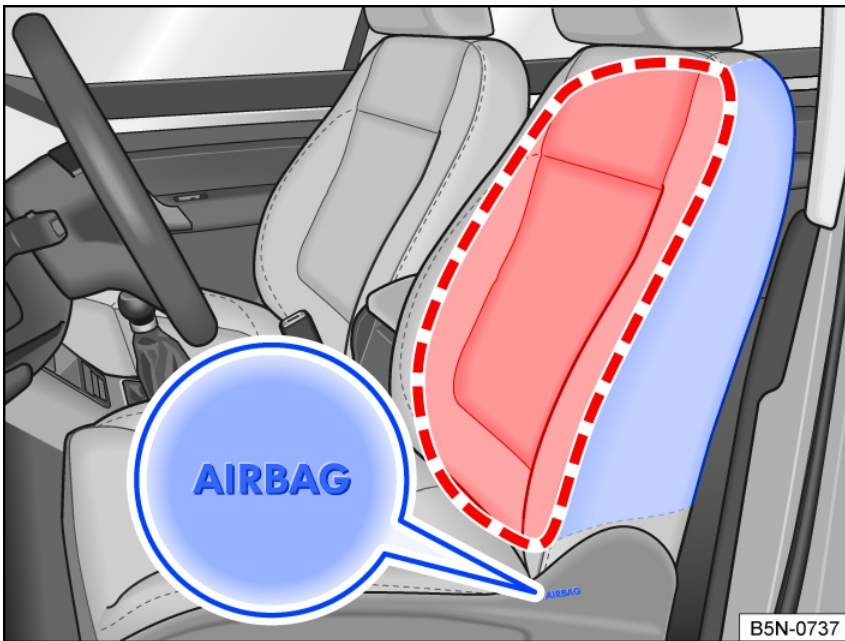



Fig. 29 On the side of the front seat: Side airbag installation location and deployment zone

The installation locations of the side airbags are marked with the word "AIRBAG".

The area outlined in red defines where the side airbags will deploy (deployment zones) *fig. 29, fig. 28*. Therefore, never place or attach objects in these areas ⇒ 

In the event of a side impact collision, the side airbags reduce the risk of injury to the vehicle occupants on the side of impact. The Side Curtain Protection® airbags will deploy on both sides.

WARNING

An airbag deploys within a few milliseconds and at a very high speed.

- Always keep the deployment zones of side airbags clear.
- Only hang lightweight clothing from the garment hooks in the vehicle. Never store heavy or sharp-edged objects in pockets.
- Do not attach any accessories to the doors.
- Only use seat covers or protective covers that are specifically approved for use in your vehicle. Otherwise, the side airbag may not expand when deployed.

WARNING

Incorrect handling and use of the driver's and front passenger's seat can inhibit the side airbags from functioning correctly and cause serious injuries.

- Never remove the front seats from the vehicle or modify parts of them.
- If too much force is applied to the seat backrest bolsters, the side airbags may not deploy correctly, deploy unexpectedly, or not deploy at all.
- Have any damage to the seat covers or the seam in the side airbag module areas repaired immediately by an authorized Volkswagen dealer or authorized Volkswagen Service Facility. Volkswagen recommends contacting an authorized Volkswagen dealer or authorized Volkswagen Service Facility.

Side Curtain Protection

 Please read the introductory information and heed the Warnings and Notice ⇒  *Introduction.*



Fig. 30 On the left side of the vehicle: installation location and deployment zone of the Side Curtain Protection®.

Side Curtain Protection® airbags are located on the driver and passenger side inside the vehicle above the doors *fig. 30*.

The installation locations of the Side Curtain Protection® are marked with the word "AIRBAG".

The area outlined in red defines where the Side Curtain Protection® airbags will deploy (deployment zone) *fig. 30*. Therefore, never place or attach objects in this area ⇒ ⚠.

In side collisions and certain head-on collisions, the Side Curtain Protection® airbags will also deploy on both sides.

Side Curtain Protection® airbags offer the "ejection mitigation" function, which protects the vehicle occupants and body parts from being completely or partially ejected from the vehicle in the event of a side impact collision or if the vehicle rolls over.

The Side Curtain Protection® airbags reduce the risk of injury to vehicle occupants in the front and outer rear seats during a side collision and certain head-on collisions.

Side Curtain Protection® airbags are composed of the following components:

- Control module and sensors.
- Side Curtain Protection airbags.
- Airbag indicator light ⇒ *Indicator light for front passenger's front airbag*.

The Side Curtain Protection® airbags do not deploy in the following situations:

- In case of crashes when the ignition is switched off.
- In certain side collisions with a low force that does not trigger the sensor.
- In case of a rear-end collision.
- In the case of certain head-on collisions.
- In certain rollovers with a low momentum that do not trigger the sensor.
- If the impact speed is too low.

⚠ WARNING

An airbag deploys within a few milliseconds and at a very high speed.

- Always keep the Side Curtain Protection® airbag deployment zones clear.
- Never attach objects to the cover or within the Side Curtain Protection® airbag deployment zone.
- There should be no people, animals, or objects between the occupants of the front seats or outer rear seats and the airbag deployment zone. Make sure that children and passengers also follow this guideline.
- Only hang lightweight clothing from the garment hooks in the vehicle. Never store heavy or sharp-edged objects in pockets.
- Do not attach any accessories to the doors.
- Do not attach any sunshades to the side windows that are not specifically approved for use in the vehicle.
- Only pivot sunshades toward the side windows if no objects such as pens or garage door openers are attached to the visor.

Knee airbags

📖 Please read the introductory information and heed the Warnings and Notice ⇒ ⚠ *Introduction*.

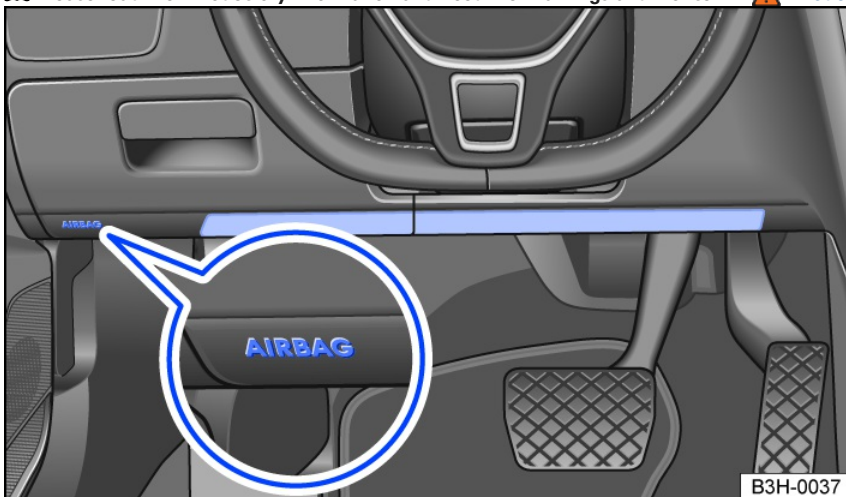

Fig. 31 On the driver side: installation location of the knee airbag.

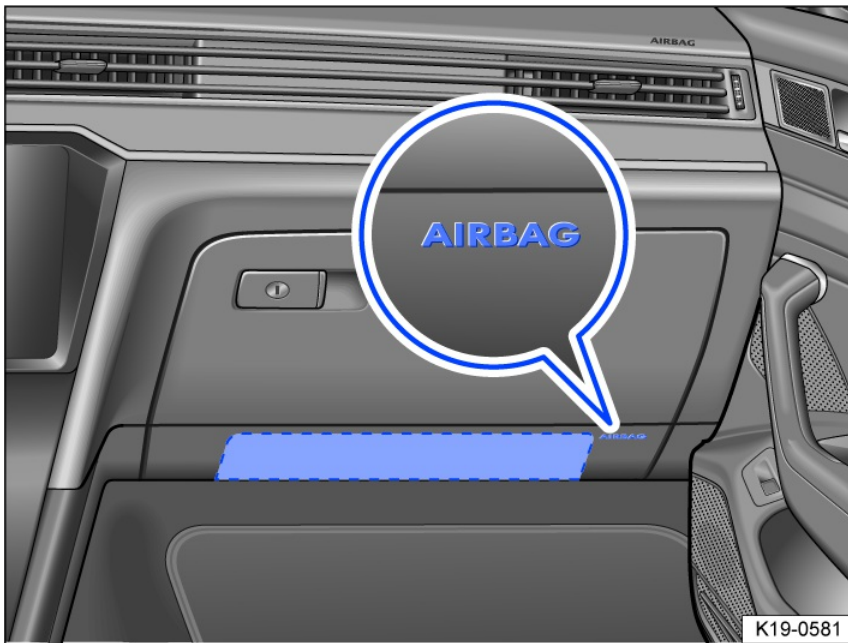

Fig. 32 On the passenger side: installation location of the knee airbag.

Depending on the vehicle equipment, a knee airbag is installed on the driver's and passenger's side in the bottom area of the instrument panel. The installation location of the knee airbag is marked with the lettering "AIRBAG" *fig. 31* and *fig. 32*.

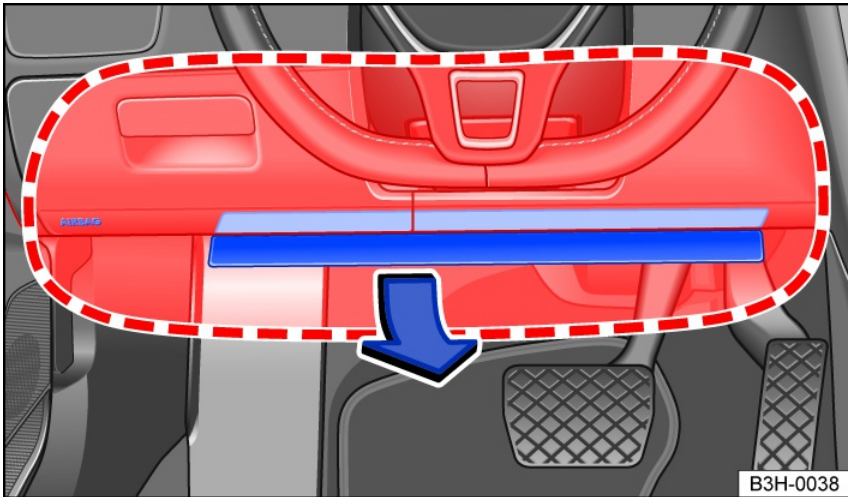

Fig. 33 On the driver side: deployment zone of the knee airbag.

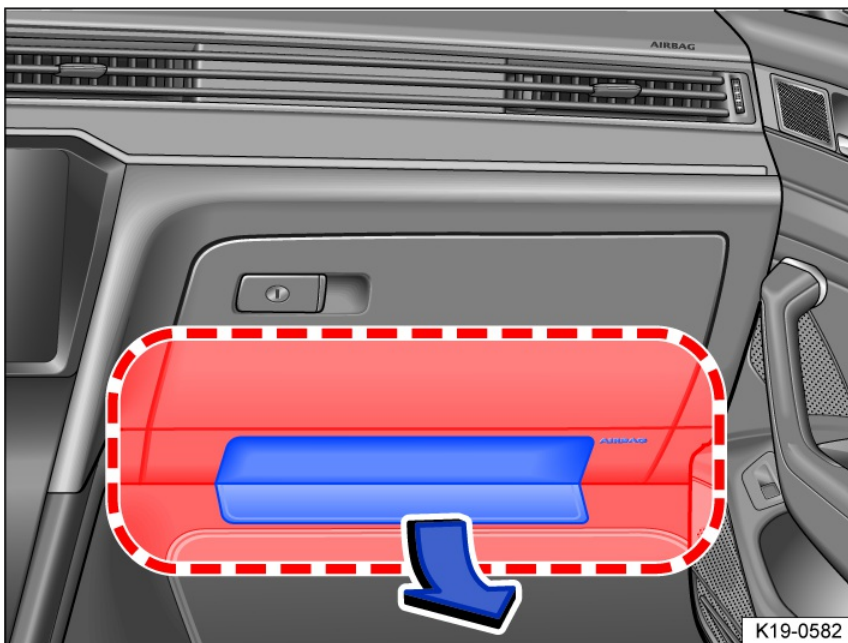

Fig. 34 On the passenger side: deployment zone of the knee airbag.

The area outlined in red defines the area where the knee airbag deploys (deployment zone) *fig. 33* and *fig. 34*. Therefore, never place or attach objects in these areas ⇒ ⚠.

WARNING

An airbag deploys within a few milliseconds and at a very high speed.

- Never use objects, e.g. key rings, which could get into the deployment zone of the knee airbag.
- Never attach objects to the cover or to the knee airbag deployment zone.
- The knee airbag deploys in front of the driver and front passenger's knees. Adjust the driver and front passenger seat so that there is at least 10 cm (approx. 4 inches) of space between your knees and the installation location of the knee airbag. If body characteristics mean that this is not possible, you must contact an authorized Volkswagen dealer or authorized Volkswagen Service Facility. Volkswagen recommends contacting an authorized Volkswagen dealer or authorized Volkswagen Service Facility.

Transporting children safely

Introduction

The physical principles in the event of an accident also apply to children. However, due to their size and other factors, they face a greater risk of injury.

Children and babies must therefore always be transported in child restraint systems that are designed for their age, size, weight and body structure. In the USA and Canada, the use of tested and certified child restraint systems is required by law.

In the case of head-on collisions at speeds of between 30 and 55 km/h (approx. 20–35 mph), a small child weighing 6 kg (13 lbs) will be subjected to forces of more than 20 times their body weight. This means that the child's effective weight will suddenly increase to up to 120 kg (260 lbs). Under such conditions, only a child restraint used in accordance with regulations can reduce the risk of injury. However, a child restraint which is not used in accordance with regulations may further increase the risk of injury!

All children (particularly children under 12 years of age) should always be transported on the rear seats in appropriate child restraint systems. However, if you must use a child restraint on the front passenger seat in exceptional circumstances, always follow all the information and warnings available at ⇒  [Introduction](#).

You can find more information on this subject at:

- National Highway Traffic Safety Administration (NHTSA): <http://www.safercar.gov> (USA).
- Transport Canada Information Centre: <http://www.tc.gc.ca> (Canada).

Read and follow the instructions from the child seat manufacturer to ensure that the seat is appropriate for your child. Also be sure to read and follow all the information and warnings on child restraint systems in this manual!

WARNING

In the event of an accident, people sitting on the front passenger seat (particularly children and small children) may suffer severe or fatal injuries if there is not sufficient distance between them and the airbag, if it is deployed (even with the Advanced Airbag System)!

- The safest place for children is on the rear seats.
- A suitable child restraint that is installed on the rear seat in accordance with regulations provides the highest level of protection for children and small children in most accidents.
- Even though the Advanced Airbag System is designed to detect child restraint systems on the front passenger seat and to switch off the front passenger's front airbag, it is not possible to guarantee that the system will perform correctly under all circumstances and over the vehicle's service life.
- In compliance with the "low risk" option for children of 3–6 years of age according to the U.S. Federal Standard, the Advanced Airbag System may be deployed if the electrical capacity of a typical one-year-old child combined with a child restraint system on the front passenger seat is exceeded and the criteria for deployment of the Advanced Airbag System are met.

WARNING

Accident statistics have shown that the rear seats offer greater safety than the front seats for children in general.

- Always transport children under 12 years of age on the rear seats.
- A child who is not secured or is not secured properly can be injured through sliding around in the vehicle interior or through being ejected from the vehicle during a sudden maneuver or collision. Secure children in the vehicle with a child restraint that is appropriate for their weight and height and with the safety belt used correctly ⇒ [Transporting children safely](#).
- A child who is not secured or not properly secured is exposed to an increased risk of injury or death through collision with an airbag. Make sure that children are not within the deployment zone of the airbag.
- A child restraint system corresponding to body weight and body size that is installed and used on the rear seats offers maximum protection for infants and small children in most accident situations.

Child restraints – overview

 Please read the introductory information and heed the Warnings and Notice ⇒  Introduction.

All children (particularly small children and infants) must be transported in child restraints suitable for them. These child restraints must always be installed correctly. The information in the following table will help you to find the suitable child restraint for your child.

Child restraint type	Use
Rear-facing child restraint	Birth–12 months old: A child of up to 12 months of age must always be transported in a rear-facing child restraint. There are different types of these: – Rear-facing child restraints for infants only. – Convertible and multi-purpose child restraints with greater weight and size restrictions for transporting your child in the rear-facing position for longer periods of time.
Rear-facing child restraint before transitioning to the forward-facing child restraint	1 – 3 years old: Transport your child in a rear-facing child restraint for as long as possible until they have reached the weight and size restrictions. After your child has reached the weight and size restrictions, you can transport them in a forward-facing child restraint with the appropriate safety belts.
Forward facing child restraints	4 – 7 years old: Transport your child in a forward-facing child restraint for as long as possible until they have reached the weight and size restrictions. After your child has reached the weight and size restrictions, you can transport them in a booster seat but only on the rear seats.
Booster seat	7 – 12 years old: Transport your child using a booster seat until they have grown enough to sit on the seats with a safety belt without a booster seat. The safety belt must be routed correctly ⇒ <i>Safety belt positioning</i> . You should continue to transport your child on the rear seats.

Child restraints can be fastened either with a three-point safety belt or with an ISOFIX/lower LATCH fastening system. Many child restraints also require the use of top tether systems. Depending on countries and federal states, the use of Top Tether may even be required by law.

How to determine whether a child restraint is installed correctly

- The child restraint lies flush against the seat cushion and the backrest unless the child restraint manufacturer allows a gap between the seat and child restraint.
- The overhang of the child restraint on the seat cushion is not longer than 20% of the child restraint. Always follow the instructions for the permitted child restraint overhangs.
- You should always position the child restraint centrally on the seat.
- The clearance of the child restraint forward and sideways is no greater than approximately 2.5 cm (1 inch).
- The child restraint must not rest on the belt buckles of the seats. These could be damaged as a result.
- When installing multiple child restraints, they must not block each other and must be free-standing and remain accessible.
- The child restraint has been secured correctly using the three-point safety belt or ISOFIX/lower LATCH anchorage point. The top tether system of the child restraint has also been used correctly as specified by the manufacturer.

DANGER

Not using the child restraint, using it incorrectly or using the wrong child restraint increases the risk of severe or fatal injuries in the event of a collision or an accident.

- Children sitting on the front seats may suffer severe or fatal injuries in the event of airbag deployment (even if advanced airbags are used).
- Children in a rear-facing child restraint on the front passenger seat may suffer severe or fatal injuries in the event of airbag deployment.
- Always install child restraints on the rear seats.
- If, in exceptional circumstances, you nevertheless install a child restraint on the front passenger seat and the yellow **OFF**  PASSENGER AIR BAG indicator light does not come on and stay on, remove the seat immediately and have the airbag system checked by an authorized Volkswagen dealer or authorized Volkswagen Service Facility. Volkswagen recommends contacting an authorized Volkswagen dealer or authorized Volkswagen Service Facility.

WARNING

If the airbag is deployed, a child restraint on the front passenger seat may collide with the airbag and the child in the child restraint may suffer severe or even fatal injuries (even if advanced airbags are used). If, in exceptional circumstances, you nevertheless install a child restraint on the front passenger seat, observe the following points:

- Forward-facing child restraints may be situated in the deployment zone of a front passenger's front airbag and may result in severe or fatal injuries if the airbag is deployed. Always ensure that the child restraint in use has been approved by the manufacturer for use on the front passenger seat.
- Read and always follow the child seat manufacturer's instructions.
- Never install a child restraint without a top tether safety belt if this is required by the manufacturer or by law.
- Never position a forward-facing child restraint directly on the instrument panel.
- Adjust the seat belt adjuster so that the seat can be installed correctly.

- Position the front passenger seat as high as possible and move it as far back as possible in order to obtain the largest possible distance to the instrument panel.
- Make sure that the upper anchorage of the safety belt is behind the child restraint to ensure that the safety belt is routed correctly.
- Make sure that the backrest is in the upright position.

⚠ WARNING

Any unused safety belts on the rear seats are a danger to your child when transported in a child restraint on the rear seats. By playing with the safety belts, the child may get tangled up and this could result in severe or fatal injuries.

- Always secure unused safety belts to the rear seat. You can do this by putting them around the head restraints which are furthest away from the installed child restraint and secure the safety belt.

ⓘ NOTICE

- Make sure not to activate the lockable belt system when you secure the safety belts that are not being used.
- Make sure that the belt is not damaged when installing the child restraint with the safety belt, particularly if you are using the lockable belt system.

Safety notes on using child restraints

📖 Please read the introductory information and heed the Warnings and Notice ⇒ ⚠ Introduction.



Fig. 35 Never allow children or infants to travel on your lap.

The correct use of child restraints significantly reduces the risk of injury in the event of an accident or collision!

All children, in particular children under the age of 12, must always travel in suitable child restraints on the rear seat.

Only use child restraints that are suitable for the height and weight of the child.

ISOFIX/lower LATCH anchorage points can be used to secure child restraints on the seats without using the vehicle's safety belts. If you do want to install a child restraint using the safety belts instead of ISOFIX/lower LATCH anchorage points, please follow all instructions given by the child restraint manufacturer for guiding the belt around the child restraint and securing the child in the child restraint. Ensure that the child restraint cannot move forward or sideways by more than 2.5 cm (1 inch) after installation.

When installing a child restraint with the safety belt, you must activate the lockable belt system.

Never activate the lockable belt system when installing a booster seat or if a child is traveling without a child restraint.

Once the child restraint is correctly installed, the settings for that seat must no longer be changed. If the seat settings have been changed, the installation of the child restraint must be checked and, if necessary, adjusted.

If a child restraint is installed on a seat, functions such as the massage function ⇒ *Massage feature* or seat heating ⇒ *Seat heating and seat ventilation* must not be used on that seat.

Important additional information for installing child restraints on the front passenger seat

If, under exceptional circumstances, you need to install a child restraint on the front passenger seat, read and follow all warnings and instructions here ⇒ 📖 *Introduction*.

You can find additional information on the selection and use of child restraints here:

Transport Canada Information Centre Tel.: 1-800-333-0371 Tel.: 1-613-998-8616 (Ottawa) <http://www.tc.gc.ca/roadsafety>

National Highway Traffic Safety Administration Tel.: 1-888-327-4236 (TTY: 1-800-424-9153) <http://www.nhtsa.gov> <http://www.safercar.gov>

National SAFE KIDS Campaign Tel.: 1-202-662-0600 <http://www.safekids.org>

SafetyBeltSafe U.S.A. Tel.: 1-800-745-SAFE or 1-800-745-7233 (English) Tel.: 1-800-747-SANO or 1-800-747-7266 (Spanish) <http://www.carseat.org>

Volkswagen Customer CARE Tel.: 1-800-822-8987

DANGER

The use of rear-facing child restraints or infant carriers on the front passenger seat can cause severe or fatal injuries.

- Always install rear-facing child restraints or infant carriers on the rear seat.

WARNING

Transporting children without a child restraint or with an unsuitable child restraint, or incorrectly installing a child restraint, increases the risk of severe or fatal injuries in the event of an accident or collision.

- Only use child restraints that are suitable for the child and that comply with the regulations set out by FMVSS 210 (CMVSS 213 in Canada).
- Only use child restraints that sit on the seat cushion of the vehicle.
- When installing the child restraint, follow the instructions given by the manufacturer of the child restraint.
- Always observe all legal requirements regarding the installation and use of child restraints.
- Children under 145 cm (around 57 inches) may only be secured and transported in the vehicle with an appropriate child restraint.
- Only one child must be allowed to travel in a child restraint.
- Never drive with children, toddlers or babies on the driver's or a passenger's lap.

WARNING

Forward-facing child restraints on the front passenger seat may collide with the airbag if it is triggered, which can lead to severe or fatal injuries.

- Always install child restraints on the rear seat.

Securing systems

 Please read the introductory information and heed the Warnings and Notice ⇒  Introduction.

Different securing systems are used for safe installation of child restraints depending on the country.

Only use the securing systems described here to secure child restraints in the vehicle.

Overview of securing systems

- **ISOFIX/lower LATCH anchorage points:** ISOFIX/lower LATCH anchorage points are attachment systems for quick and secure attachment of child restraints in the vehicle. Attachment using ISOFIX/lower LATCH anchorage points creates a fixed connection between the child restraint and the vehicle.

The child restraint can have two fixed or flexible attachment arms. The attachment arms snap into the ISOFIX/lower LATCH anchorage points that are located between the seat cushion and the rear seat backrest ⇒ *Fastening a Child Restraint with ISOFIX or Lower LATCH Anchorage Point*. Reinforce the attachment using the ISOFIX/lower LATCH anchorage points by attaching with a top tether safety belt or a support bracket, if necessary.

- **Three-point safety belt:** Child restraints can be fastened with a three-point safety belt ⇒ *Securing a child restraint with a safety belt*.

Additional fasteners:

- **Top Tether:** the upper belt is guided over the rear seat backrest and secured to the anchorage point on the rear side of the rear seats using a hook ⇒ *Securing the child restraint with the upper strap (top tether)*. Top tether anchorages are labeled with an anchor symbol.
- **Support base:** some child restraints are supported with a support base on the vehicle floor. The support base reduces the risk of the child restraint tipping forward in the event of a collision. Only use child restraints with a support foot on the front passenger seat and the outer seats in the second row of seats ⇒ 

WARNING

Incorrect use of the support base can cause severe or fatal injuries.

- Make sure the support base is installed correctly and securely.

Fastening a Child Restraint with ISOFIX or Lower LATCH Anchorage Point

 Please read the introductory information and heed the Warnings and Notice ⇒  Introduction.

Installing child restraints with ISOFIX/lower LATCH anchorage point



Fig. 36 On the outer seats in the rear bench seat: Designation of the ISOFIX/lower LATCH anchorage points for child restraints.



Fig. 37 General example: fitting a child restraint with attachment arms.

The installation location of the ISOFIX/lower LATCH anchorage points is indicated by a symbol [fig. 36](#).

1. Pay attention to and follow the information → page , *Safety notes on using child restraints*.
2. If necessary, fold down the protective caps of the ISOFIX/lower LATCH anchorage points.
3. Push the attachment arms of the child restraint in the direction of the arrow onto the ISOFIX/lower LATCH anchorage points [fig. 37](#). The child restraint must engage securely and audibly.
4. Pull on both sides of the child restraint to check that the child restraint is securely locked in place.

If the child restraint is equipped with a support foot, this support foot must be positioned securely on the vehicle floor.

Using insertion guides

If the lower LATCH anchorage points for child restraints are not directly accessible, guidance fixtures can make the installation and removal of child restraints easier. To do this, first position the guidance fixtures at the lower LATCH anchorage points. Then fasten the child restraint according to the installation instructions.

⚠ NOTICE

Prevent permanent marks or damage to seat covers and cushions due to insert guides.

- Before folding the rear seats forward or when removing the child restraint, always remove the guidance fixtures from the ISOFIX/lower LATCH anchorage points.

Securing the child restraint with the upper strap (top tether)

📖 Please read the introductory information and heed the Warnings and Notice ⇒ ⚠ Introduction.

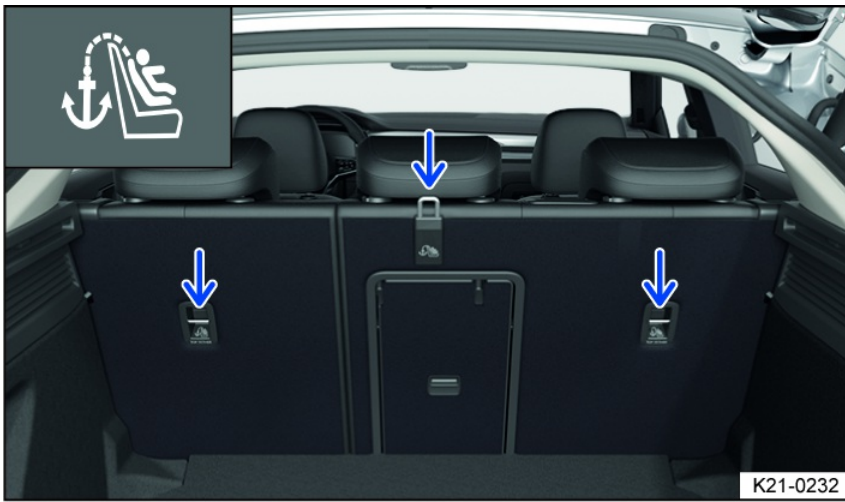

Fig. 38 On the rear side of the rear bench seat: Top tether anchorages for the top tether safety belt.



Fig. 39 On the rear side of the outer seats of the second row of seats: Attached top tether safety belt.

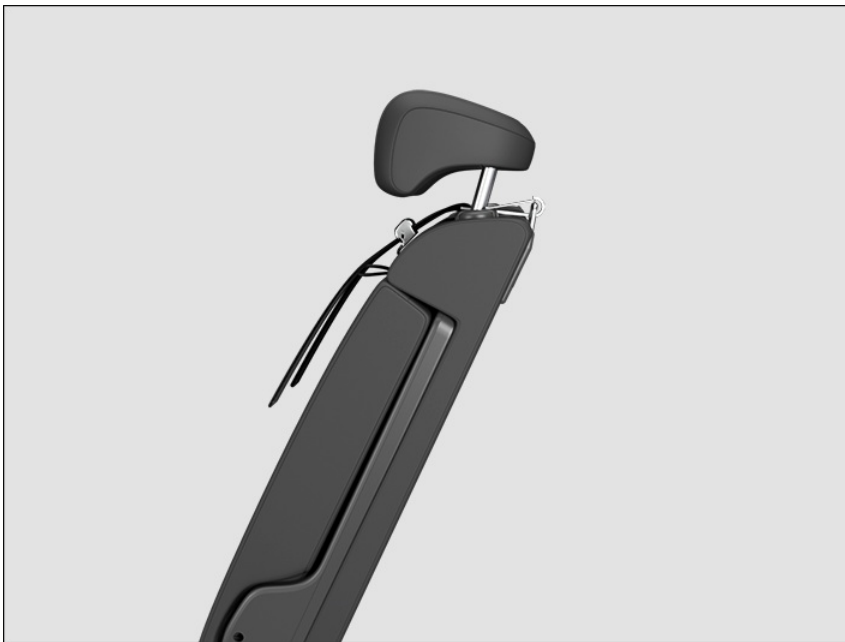

Fig. 40 On the rear side of the middle seat of the second row of seats: Attached top tether safety belt.

Top tether safety belts reduce the forward movement of the child restraint during an accident. This reduces the risk of a head injury to the child.

The anchorages suitable for top tether are labeled with a symbol and may have the label "TOP TETHER" *fig. 38*. Fasten the top tether safety belt only to the top tether anchorages designed for this purpose.

Fastening the top tether safety belt

1. Pay attention to and follow the information → page , *Safety notes on using child restraints*.
2. Prepare the top tether safety belt on the child restraint according to the child restraint manufacturer instructions ⇒ ⚠.
3. If necessary, remove the luggage compartment cover and screen separator.
4. Place the child restraint in the center of the vehicle seat cushion and fasten it securely according to the child restraint manufacturer instructions.
5. If necessary, move the rear seat backrest of the vehicle seat to an upright position and adjust to the backrest of the child restraint.
6. Locate the top tether anchorage for the respective seat *fig. 38*.
7. If necessary, push the head restraint upwards and guide the top tether safety belt of the child restraint to the rear under the head restraint.
Applies to child restraints with a V-shaped top tether safety belt: Check that the top tether safety belt is taut on the seat and is not redirected by the bars of the head restraint.
8. Guide the top tether safety belt of the child restraint back over the seat.
9. Hook the top tether safety belt into the appropriate anchorage marked with "top tether" *fig. 39, fig. 40*.
10. Pull on the top tether safety belt.
11. Check that the hook of the top tether safety belt is closed.
12. Tighten the top tether safety belt according to the child restraint manufacturer instructions ⇒ ⚠.
13. If necessary, guide the head restraint back into the starting position.

⚠ WARNING

Fastening the child restraint incorrectly increases the risk of serious and fatal injury during an accident.

- Always follow the child restraint manufacturer instructions for fastening the child restraint in the vehicle.
- Never fasten a child restraint without the top tether safety belt if the use of a top tether safety belt is prescribed by the child restraint manufacturer or legally required for the child restraint.

For example, the use of a top tether safety belt in conjunction with a forward-facing child restraint is legally required in Canada.

- Always make sure that the top tether safety belt is installed taut. If it is not possible to make the top tether safety belt taut on the center seat of the second row of seats, use one of the outer seats of the second row of seats for installing the child restraint, in order to install the top tether safety belt taut.
- Improper fastening of the top tether safety belt can lead to serious injuries during an accident. The top tether anchorages are only approved for correctly installed child restraints.
- Always only fasten a top tether safety belt of a child restraint to a top tether anchorage.
- Never fasten a child restraint top tether safety belt to a tie-down.
- Never fasten a safety belt or another belt of the child restraint to a top tether anchorage.
- Never fasten luggage or other objects to a top tether anchorage.

Releasing the top tether safety belt

1. Release the top tether safety belt according to the child restraint manufacturer instructions.
2. Release the catch on the hook and release the top tether safety belt from the top tether anchorage.

Securing a child restraint with a safety belt

📖 Please read the introductory information and heed the Warnings and Notice ⇒ ⚠ *Introduction*.

Locking the safety belt

If a child restraint is fastened with a safety belt, the safety belt must be locked. Note the instructions provided by the child restraint manufacturer.

If a safety belt is locked, the belt cannot unwind. A locked safety belt prevents the safety belt being released during the journey, which can mean that the child restraint is no longer sufficiently secured.

1. Pay attention to and follow the information → page , *Safety notes on using child restraints*.
2. If available, adjust the height of the safety belt so that the belt webbing runs naturally along the child restraint without any sharp bends in the webbing.
3. Install the child restraint according to the guide from the child restraint manufacturer and ensure that the safety belt meant for the seat is used.
4. Insert the buckle tongue into the belt buckle belonging to the corresponding seat, until the buckle tongue latches into place.
5. Check that the safety belt is not twisted.
6. Check that the lap section of the safety belt is taut.
7. Completely pull out the shoulder belt section of the safety belt and then let it gently roll up.

While the safety belt is being rolled up, a clicking sound can be heard. Once the safety belt is locked, it cannot be further pulled out.

8. Press the child restraint into the seat and let the safety belt roll up further. If necessary, return the shoulder belt section of the safety belt to the automatic safety belt retractor by hand.
9. Pull the belt guide of the child restraint.

Check that the child restraint cannot move further than 2.5 cm (approx. 1 inch).

Releasing the locked safety belt

The lockable safety belt may only be used to fasten certain child restraint systems in the vehicle. An activated locking mechanism must be released when a vehicle occupant fastens their safety belt.

1. Release the safety belt from the belt buckle.
2. Remove the child restraint according to the instructions from the child restraint manufacturer.
3. Press the red button in the belt buckle and guide the safety belt back fully by hand.

The safety belt is no longer locked.

Keep any safety belts that are not being used out of the reach of children



Fig. 41 Keep any safety belts that are not being used away from children.

Secure any safety belts not being used to prevent a child from playing with the safety belt and getting caught in it. The procedure for securing a safety belt that is not being used depends on the seating position.

To secure a safety belt that is not being used for one of the outer seats:

1. Position the safety belt around the head restraint of the center seating position [fig. 41](#).
2. Make sure that the safety belt is out of range of any children so that children cannot touch it or play with it.
3. Make sure that the safety belt is not blocking the lower anchors.

If the anchor points are blocked, this may mean that you cannot install the child restraint properly in the anchor points.

4. Do not activate the lockable safety belt.

Otherwise, it is very difficult to retract the safety belt into its normal position. You should not hear any clicking noises when the safety belt is retracted.

To secure a safety belt that is not being used for the middle seat:

1. Fasten the safety belt [fig. 41](#).
2. Pull the shoulder strap on the safety belt out fully to activate the lockable safety belt. You should hear a clicking noise when the safety belt is rolled up again.
3. Let the safety belt roll up fully. Pull the safety belt to make sure that the lockable safety belt is activated and the safety belt is properly fastened and tightened so that the child cannot get hold of the belt or play with it.

If a child is secured on a seat in the second row, adjust the position in front of the child restraint to ensure that the child has enough space. For example, adjust the front passenger seat to the size of the child and the child directly behind them. Always pay attention to the correct seating position \Rightarrow [Seating position](#).

If no child restraints are needed, move all the safety belts back into their normal storage positions so that the safety belts are available for normal use.

Installing on the center seating position

When installing a child restraint on the center seating position, it is especially important to install correctly because this seating position is narrower than both of the outer seats. If the child restraint is wider than the seat surface, the belt buckle of the adjacent seating position may be covered and could then be damaged. When

installing child seats, always ensure that all belt buckles are easily accessible.

- If nothing else is specified by the child restraint manufacturer, the child restraint must rest close against the backrest and seat surface and must not overlap seat surfaces.
- The child restraint must be installed straight and centered on the seating position, and it must not be able to move more than 2.5 cm (approx. 1 inch).
- The child restraint must not rest on the belt buckles.
- When installing multiple child restraints, the child restraints must not become caught on one another.

In some cases, even if a child restraint is installed correctly on the center seating position, it may cover the belt buckles and could then damage them and make the belt buckles unusable. This can occur if the child restraint slides on the seat surface while driving. Therefore, check the position of the child restraint regularly to ensure that the belt buckles are neither covered nor damaged.

⚠ WARNING

A child that is in a child restraint that has been secured with the anchor points or with a safety belt may play with any unused safety belts on the rear seat and get tangled up, which could result in serious or even fatal injuries.

- Always keep any safety belts for the rear seats that are not being used out of the reach of children.

Securing a booster seat with a safety belt

📖 Please read the introductory information and heed the Warnings and Notice ⇒ **⚠ Introduction.**



Fig. 42 Correctly fastened child on a booster seat.

Children between the ages of around 8 and 12 are best protected when they travel on a booster seat that is suitable for their age and height.

The safety belts of the vehicle generally only fit children 145 cm (approx. 57 inches) tall or taller. Booster seats ensure that children under this height can be correctly fastened using the safety belt.

- Never activate the lockable belt system when securing a child with a booster seat.
- The upper area of the belt must always be positioned on the child's shoulder. Ensure that the belt does not rest on the child's face or neck.
- The lap belt must always run across the child's lap. It must never run across the child's stomach.

Children over 145 cm (approx. 57 inches) tall can generally be fastened with the safety belt. Pay attention to the information at ⇒ [Safety belt positioning.](#)

Your child no longer needs a booster seat if they are taller than 145 cm (approx. 57 inches) and the following conditions are met:

- The child can sit with their back fully against the backrest.
- The child's knees bend over the edge of the seat.
- The child's feet sit fully flat on the vehicle floor.
- The child can comfortably stay in this position for the entire journey.

Children aged 12 or under must always travel on a rear seat.

⚠ WARNING

Not using a booster seat or incorrectly using a booster seat or safety belt can cause severe or fatal injuries in the event of an accident or collision.

- Always observe all instructions regarding the installation and use of child restraints and booster seats.

- If, under exceptional circumstances, you need to install a booster seat on the front passenger seat, ensure that the PASSENGER AIR BAG OFF  indicator light turns on and remains on.

In case of an emergency

Securing yourself and the vehicle

Follow all legal regulations regarding securing a vehicle during a breakdown. For example, in many countries you must switch on the emergency flashers and wear a reflective vest ⇒ [Emergency equipment](#).

Checklist

For your own safety and the safety of your passengers, follow the points below in the order they are given ⇒ :

1. Park your vehicle a safe distance from traffic and on suitable ground. Observe all important information on parking when doing so ⇒ , ⇒ [Parking](#).
2. Switch on the emergency flashers ⇒ [Center console](#).
3. Have all vehicle occupants exit the vehicle on the side facing away from traffic and move to a safe area, such as behind a guard rail. Follow the local regulation regarding wearing a reflective vest.
4. Set up the warning triangle to warn others on the road about the vehicle.
5. Observe the safety instructions → page , [Safety precautions for working in the engine compartment](#).
6. If necessary, contact an authorized Volkswagen dealer or authorized Volkswagen Service Facility for assistance. Volkswagen recommends contacting the Volkswagen emergency assistance service.

When the emergency flashers are switched on, for example while towing the vehicle, you can indicate any turns or lane changes using the turn signal lever. The emergency flashers will stop temporarily.

Read and observe the important information about towing ⇒  [Introduction](#).

Switch on the emergency flashers in the following situations, for example:

- To warn traffic behind your vehicle if the traffic ahead slows suddenly or you reach the end of a traffic jam.
- If there has been an accident.
- If the vehicle malfunctions.
- When towing the vehicle.

Always follow the applicable local requirements for use of the emergency flashers.

If the emergency flashers do not work, others on the road must be informed about the stalled vehicle in some other way that meets the applicable legal regulations.

WARNING

A stalled vehicle increases the risk of a crash that could cause injury to you, your vehicle occupants, or others on the road.

- Stop the vehicle as soon as it is safe to do so.
- Park the vehicle a safe distance from moving traffic.
- Switch on the emergency flashers.
- Never leave any persons, particularly children or people requiring assistance, in the vehicle. This is especially true when the doors are locked. Individuals locked in the vehicle could be exposed to very high or very low temperatures.

WARNING

Failing to heed this checklist that is provided for your own safety can cause accidents and serious injuries.

- Always follow the activities in the checklist and follow the general safety precautions.

WARNING

Exhaust system components will become very hot. This can result in fires and serious injuries.

- Never park the vehicle in such a way so that any exhaust system components could come into contact with flammable materials under the vehicle such as dry grass or fuel.

NOTICE

When pushing the vehicle by hand, do not press on the taillights, the rear spoiler, or large pieces of sheet metal. Doing so could cause vehicle damage and the rear spoiler may detach.

 The 12 V vehicle battery will drain if the emergency flashers remain on for a long period of time, even if the ignition is switched off.

 Depending on vehicle equipment, the brake lights may blink quickly if you brake hard while driving at speeds above approx. 50 mph (approx. 80 km/h) or brake the vehicle to a complete stop. This is done to warn traffic behind your vehicle. If the braking continues, the emergency flashers will switch on automatically when the vehicle speed is below approx. 6 mph (approx. 10 km/h). The emergency flashers will switch off automatically when you accelerate.

Emergency equipment

First aid kit

Depending on the country and the vehicle equipment, the first aid kit may be located in a storage compartment, in a holder in the luggage compartment, under the luggage compartment floor, or in the vehicle interior.

The first aid kit must meet the legal regulations.

- Note the expiration date of the contents.
- Replace contents after use, if necessary, and put the first aid kit securely back into place.

Warning triangle

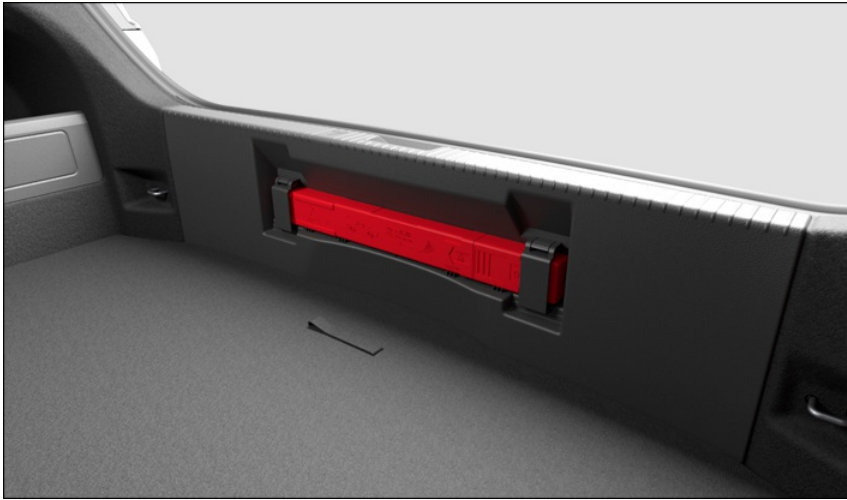

Fig. 43 Underneath the load sill: holder for the warning triangle.

Depending on the country and the vehicle equipment, the warning triangle may be in a holder underneath the loading edge [fig. 43](#).

1. Press on both catches of the holder.
2. Open the catches and remove the sleeve of the warning triangle.
3. After use, store the warning triangle back in the sleeve, insert the sleeve back into the holder and lock it.

The warning triangle must meet the legal regulations.

Reflective vest

Depending on the country and the vehicle equipment, the safety vest may be located in a storage compartment in the front door trim panel or in the glove compartment → [Driver door](#), → [Passenger's side](#).

The reflective vest must meet the legal regulations.

Fire extinguisher

Depending on the vehicle equipment and country of use, a fire extinguisher may be located in a holder in the footwell under the front passenger seat.

The fire extinguisher must meet the legal regulations, always be ready to operate, and be checked regularly – see inspection seal on the fire extinguisher.

WARNING

Objects that are loose or secured incorrectly can be thrown around the vehicle interior during sudden driving or braking maneuvers or in a collision and cause serious injuries.

- Always position the first aid kit, warning triangle and fire extinguisher securely in the holders provided in the vehicle.
- Store the reflective vest in a storage compartment so that it is easy to access.

Re-active hood



Fig. 44 Triggered re-active hood (general example).

In a front-end collision, the re-active hood is triggered by sensors in the front bumper at speeds of around 15–34 mph (around 25–55 km/h). This raises the hood in front of the windshield by a few centimeters, for example to create an additional crumple zone above the engine in the head area for a pedestrian who has been hit. The “re-active hood” system can only be correctly deployed if the hood has not been previously deformed by external forces.

In some cases the system may trigger even when there is no pedestrian involved in the collision. The system may, for instance, be triggered in the following situations:

- Front impact with objects or animals.
- A gentle collision or impact on uneven ground.

When the re-active hood is triggered, the hood in front of the windshield is raised by a few centimeters. Special hinges lock the engine hood in the open position [fig. 44](#) (magnifying glass). In addition, a message is displayed in the instrument cluster display until the system is repaired.

When the re-active hood is triggered, complete the following instructions:

- Contact an authorized Volkswagen dealer or authorized Volkswagen Service Facility directly. Volkswagen recommends contacting an authorized Volkswagen dealer or authorized Volkswagen Service Facility.
- The system must be repaired by an authorized Volkswagen dealer or authorized Volkswagen Service Facility. Volkswagen recommends contacting an authorized Volkswagen dealer or authorized Volkswagen Service Facility.
- You may only continue driving when the vehicle is roadworthy again.
- Do not drive faster than around 50 mph (80 km/h).
- If necessary, adjust your seat position ⇒ [Seating position](#). You must have a clear, unhindered view through the windshield even with the re-active hood triggered.
- If your vehicle has a trailer mode, uncouple the trailer.

Repairing the triggered re-active hood

A triggered re-active hood may only be repaired by an authorized Volkswagen dealer or authorized Volkswagen Service Facility ⇒ . Volkswagen recommends contacting an authorized Volkswagen dealer or authorized Volkswagen Service Facility.

WARNING

The intelligent technology of the pedestrian protection system “re-active hood” cannot overcome the natural laws of physics and it can only operate within the limits of the system. Do not allow the increased protection offered by the pedestrian protection system “re-active hood” tempt you into taking risks.

- Always adapt your speed and driving style to the visibility, weather, road and traffic conditions.
- Do not drive faster than around 50 mph (80 km/h) with a triggered re-active hood.

WARNING

Repairs and modifications that are performed incorrectly can cause vehicle damage and malfunctions as well as impair the effectiveness of the driver assistance systems. This can cause accidents and serious injuries.

- Only have repairs or modifications made to your vehicle by an authorized Volkswagen dealer or authorized Volkswagen Service Facility. Volkswagen recommends contacting an authorized Volkswagen dealer or authorized Volkswagen Service Facility.

⚠ WARNING

Improper closing of the triggered re-active hood can cause accidents and severe injury, especially to the hands.

- A triggered re-active hood may only be repaired by an authorized Volkswagen dealer or authorized Volkswagen Service Facility. Volkswagen recommends contacting an authorized Volkswagen dealer or authorized Volkswagen Service Facility. Never attempt to close the engine hood yourself.

! NOTICE

Improper closing of the triggered re-active hood may damage the vehicle.



- Under no circumstances should you attempt to push down a triggered re-active hood, for example with your hands on the engine hood. The engine hood and its hinges may be damaged by this.

 The symbols in the instrument cluster display may vary depending on the version.

Information Call, Roadside Assistance Call and Emergency Call Service



Fig. 45 In the roof console: Controls for call services and indicator light.

-  Information call.
-  Roadside assistance call.
-  Emergency Call Service.

The control in the roof console *fig. 45* can be used for voice services, depending on the vehicle equipment and country of use. The required connection is produced by a control module installed by the manufacturer.

 **Note the additional information on VW Car-Net®** ⇒ .

Indicator lights for the Emergency Call Service

An indicator light *fig. 45* (arrow) for voice and data transmission services is located in the control panel. The indicator light comes on in different colors and light patterns depending on the vehicle operating status of the Emergency Call Service:

 **The indicator light does not light up: The vehicle is offline and has no connectivity.**  **The red indicator light comes on and remains on: system error. The Emergency Call Service is limited or not available.**  **The green indicator light lights up: Displays the availability of mobile radio signal. Does not display whether VW Car-Net services have been purchased and are active, except for the Emergency Call Service.**  **The indicator light blinks green: there is a call in progress.**

Information call

- With an information call, a call can be made to the VW Car-Net call center for questions regarding VW Car-Net services.
- The contact person will communicate in the language of the country in which the vehicle was registered with VW Car-Net, or in the language of the country for which the vehicle was produced.

Roadside assistance call

- If you break down, you can contact an authorized Volkswagen dealer or authorized Volkswagen Service Facility for assistance with the roadside assistance call.
- Some vehicle data, e.g. its current location, is transferred in parallel to the voice call.
- The contact person will communicate in the language of the country in which the vehicle was registered with VW Car-Net, or in the language of the country for which the vehicle was produced.

Emergency Call Service

- Using the Emergency Call Service, assistance can be organized as quickly as possible in dangerous situations.
- The Emergency Call Service is only available if a corresponding license is acquired.

- If the Emergency Call Service is triggered, a call to the VW Car-Net call center will be made.
- If an emergency call is triggered manually or by a collision with airbag deployment or safety belt pretensioner deployment, data that is relevant to the emergency call, such as the vehicle's current location, is automatically transmitted ⇒ *Customer information*.
- The contact partner will communicate in the language that is set in the vehicle's Infotainment system. If this language is not available at the current emergency call location, English will be used.

WARNING

The following conditions may restrict or prevent a manual or automatic emergency call:

- The emergency call location is in an area with no cell phone and satellite reception, or insufficient reception.
- You are in a location where there is sufficient mobile phone and satellite reception, but the telecommunications provider's mobile communications network is unavailable.
- The Emergency Call Service is not permitted by law in some countries.
- VW Car-Net has not been activated.
- No valid license for the use of the Emergency Call Service has been acquired or the license has expired.
- The vehicle components required for manual or automatic emergency calls are damaged or do not have sufficient power.
- The vehicle's ignition is not switched on.

Triggering an emergency call manually

1. If fitted, press on the button cover briefly and fold the cover downward.
2. Press the emergency call button *fig. 45* until the green indicator light starts to flash.

The emergency call is triggered and a voice call to the VW Car-Net call center is established.

If you pressed the emergency call button by mistake, cancel the emergency call immediately:

1. Press the emergency call button again until the indicator light remains green.

Automatic emergency call

The automatic emergency call is only triggered when the ignition is on.

A call will automatically be made to the VW Car-Net call center immediately after the airbags or safety belt pretensioners deploy. The automatic emergency call cannot be stopped by pressing the emergency call button *fig. 45*.

If questions from the VW Car-Net® call center are not answered, rescue operations will automatically start.

Integrated battery

The integrated battery ensures that the Emergency Call Service will still be available for some time if the 12 V vehicle battery is disconnected or faulty.

If the integrated battery is drained or faulty, a message indicating this will be displayed in the instrument cluster. If this message is shown, immediately consult an authorized Volkswagen dealer or authorized Volkswagen Service Facility and have the integrated battery replaced. Volkswagen recommends contacting an authorized Volkswagen dealer or authorized Volkswagen Service Facility.

 **Have the integrated battery checked, and if necessary, replaced by an authorized Volkswagen dealer or authorized Volkswagen Service Facility after approximately three years. Volkswagen recommends contacting an authorized Volkswagen dealer or authorized Volkswagen Service Facility.**

Data transmission

The available data will be sent to the VW Car-Net call center during an emergency call to determine what rescue measures are needed.

The data regarding the location of the vehicle is continuously overwritten, so that only the ten most recent saved locations as required for the Emergency Call Service to function are available. The vehicle cannot be tracked on a continuous basis.

The emergency call data is only processed to ensure the proper function of the Emergency Call Service.

The following data will be sent:

- The current vehicle position at the time the emergency call was triggered
- Nine other vehicle positions shortly before the emergency call was triggered (from the route driven, a few km (around 2 miles)).
- Vehicle Identification Number (VIN)
- Type of vehicle drive.
- Vehicle model
- Trigger type (automatic or manual)
- Call type.
- Direction in which the vehicle was moving at the time the emergency call was triggered.

- Accident severity.
- Accident direction.
- Time of impact
- Reliability of the positioning data
- Data set version.
- Counter of the data sets transmitted per call
- Calculated number of passengers.
- Language selected in the Infotainment system.
- Optional data ID.

 **The Emergency Call Service function may be limited by any after-market Infotainment systems that are installed.**

Troubleshooting

Emergency Call Service malfunction

The red indicator light in the emergency call button comes on and remains on . The message  Error: Emergency call function. Service vehicle may also be displayed in the instrument cluster.

There is a system error with the Emergency Call Service. You may not be able to make an emergency call.

1. Contact an authorized Volkswagen dealer or authorized Volkswagen Service Facility immediately and have the fault rectified. Volkswagen recommends contacting an authorized Volkswagen dealer or authorized Volkswagen Service Facility.

Emergency Call Service limited

The red indicator light in the emergency call button comes on and remains on . The message  Emergency call function limited. Service vehicle may also be displayed in the instrument cluster.

The Emergency Call Service function has restricted availability. For example, you cannot make a voice call to the VW Car-Net® call center.

1. Contact an authorized Volkswagen dealer or authorized Volkswagen Service Facility immediately and have the fault rectified. Volkswagen recommends contacting an authorized Volkswagen dealer or authorized Volkswagen Service Facility.

Opening and Closing

Vehicle key

Vehicle key functions

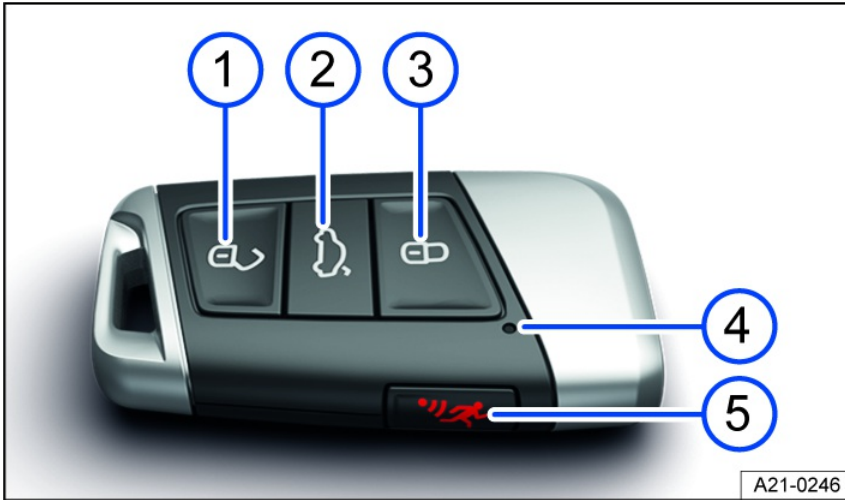

A21-0246

Fig. 46 Vehicle key without key bit.

- ① Unlock the vehicle. All turn signals will flash twice.
- ② Unlock the trunk lid separately. All turn signals will flash twice.
- ③ Lock the vehicle. All turn signals will flash once.
- ④ Indicator light: flashes when a button is pressed.
- ⑤ Panic button (depending on vehicle equipment).

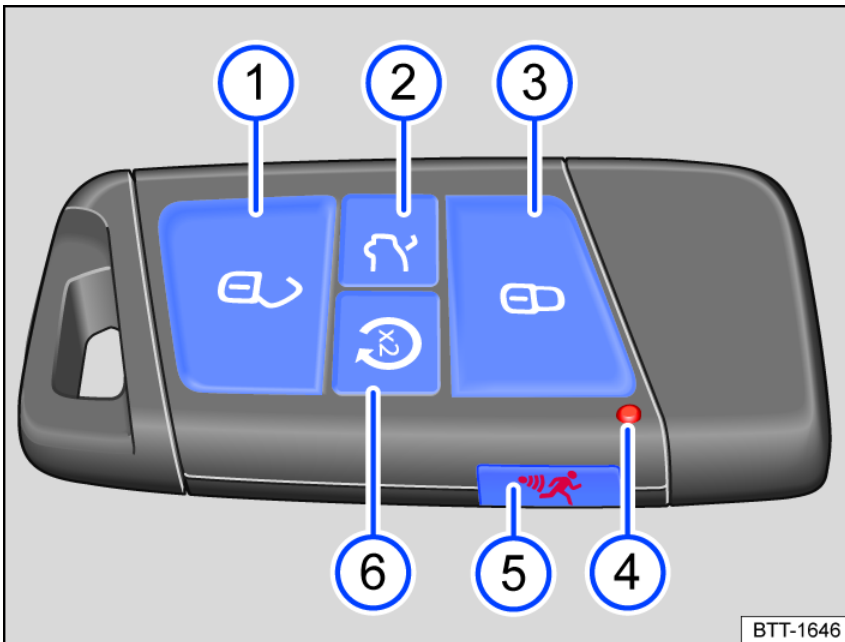

BTT-1646



Fig. 47 Vehicle key with remote start relay function.

- ① Unlock the vehicle. All turn signals will flash twice.
- ② Unlock the trunk lid separately. All turn signals will flash twice.
- ③ Lock the vehicle. All turn signals will flash once.
- ④ Indicator light: flashes when a button is pressed.
- ⑤ Panic button (depending on vehicle equipment).
- ⑥ Remote start relay function (depending on the vehicle equipment).

Panic button (depending on vehicle equipment)

Only use the panic button  in case of an emergency. When you press the panic button, the horn will sound and the vehicle lights will flash. Pressing the panic button again switches off the alarm.

Remote start relay button (depending on vehicle equipment)

1. To carry out the remote start, press the  button once and press the  button twice ⇒ *Remote start function*.

During remote start, the parking light turns on. Pressing the  button switches off the engine.

⚠ WARNING

Careless or unintended use of the vehicle key can cause crashes and serious injuries.

- Always take all vehicle keys with you when leaving the vehicle. Children or unauthorized people could lock the doors and/or the trunk lid, start the engine, or switch on the ignition and activate electrical equipment, such as the power windows.
- Never leave children or people requiring assistance alone in the vehicle. In an emergency, they will not be able to leave the vehicle unassisted or care for themselves. For example, depending on the season, the temperature inside the vehicle could become very high or low, which can lead to serious injuries, illness or death, especially for very young children.

ⓘ NOTICE

Protect the vehicle key from moisture and strong impacts.

 Regular use of comfort systems and other usage patterns shorten the service life of the button cell in the vehicle key.

Emergency key (vehicle key without key bit)

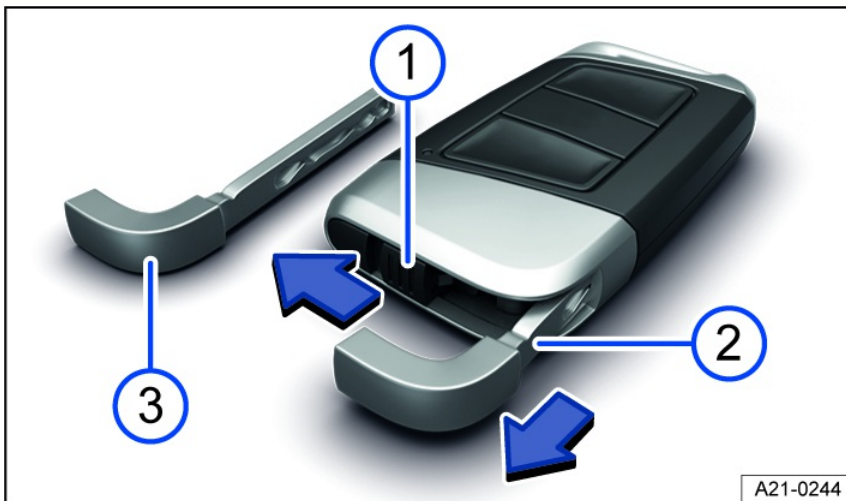

Fig. 48 Vehicle key: Unlocking the emergency key (general example).

- ① Push the locking mechanism in the direction of the arrow.
- ② Remove the emergency key in the direction of the arrow.
- ③ Emergency key.

There may be an emergency key *fig. 48* ③ located in the vehicle key that can be used to manually unlock and lock the vehicle.

Possible functions:

- Unlock and lock the glove compartment.
- Unlock and lock the vehicle manually ⇒ *Vehicle key functions*.
- Switch the childproof lock on and off ⇒ *Child safety lock*.

Replacing the button cell battery

Volkswagen recommends having the button cell changed by suitably qualified professionals. Volkswagen recommends contacting an authorized Volkswagen dealer or authorized Volkswagen Service Facility ⇒ .

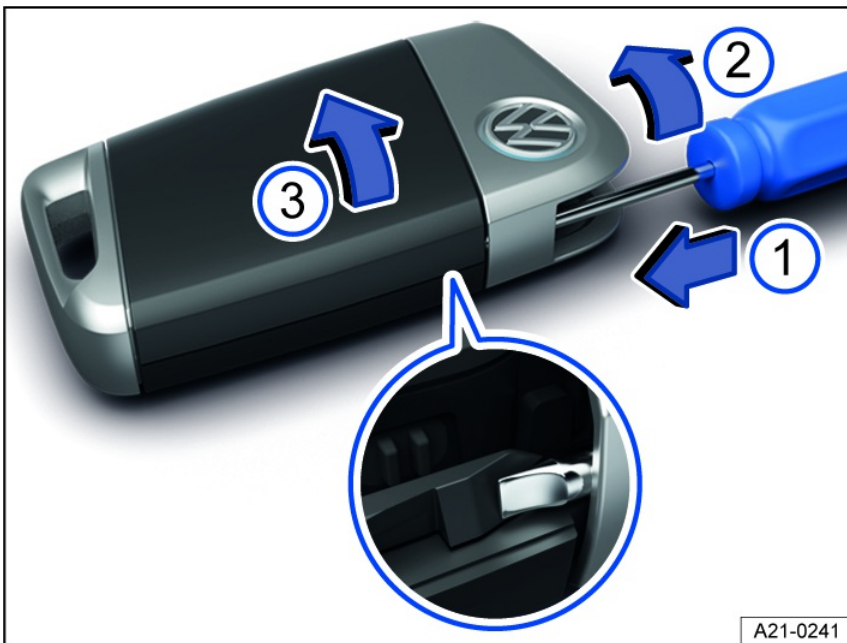

A21-0241

Fig. 49 Vehicle key: opening the battery compartment cover.

- ① Insertion into the outer guide.
- ② Direction of rotation of the flat-bladed screwdriver.
- ③ Cover



A21-0242

Fig. 50 Vehicle key: replacing the button cell battery

1. Remove the emergency key ⇒ *Emergency key (vehicle key without key bit)* .
2. Slide the blade of the flat-bladed screwdriver in the direction of the arrow approximately 1 cm (approx. 0.4 in) into the outer guide on the emergency key in the remote control vehicle key *fig. 49*.
3. Turn the flat-bladed screwdriver clockwise until the cover pops up *fig. 49*.
4. Push the cover in the direction of the arrow and remove it *fig. 49*.
5. Lift the button cell battery out of the battery compartment *fig. 50* , ⇒ ⚠.
6. Press the new button cell battery into the battery compartment.
7. Press the cover out of the housing *fig. 49* , ⇒ ⚠.
8. Store the emergency key ⇒ *Emergency key (vehicle key without key bit)* .
9. Dispose of drained battery in a way that will not harm the environment.

⚠ DANGER

If button cell batteries are swallowed or enter the windpipe, serious or fatal injuries will occur within a very short time due to choking or internal burns.

- Seek medical assistance immediately if you suspect that a button cell battery has been swallowed.
- Always keep the remote control and key fob with button cell batteries out of the reach of children.

! NOTICE

If the button cell battery is replaced incorrectly or batteries are unsuitable, it can damage the vehicle key.

- Only replace a drained battery with a new battery of the same voltage, size, and specification.
- Make sure the battery is facing in the right direction when inserting it.
- If the battery cover cannot be closed, do not use the remote control.

 The type of batteries used in the remote control of your vehicle key can contain perchlorate. This requires special handling. Observe all legal requirements regarding the handling and disposal of these batteries ⇒ [Disposal of old batteries and electronic devices](#). Volkswagen recommends having this service carried out for you by suitably qualified professionals. Volkswagen recommends contacting an authorized Volkswagen dealer or authorized Volkswagen Service Facility.

Synchronizing a vehicle key

If the vehicle cannot be unlocked or locked using the vehicle key, synchronize the vehicle key or replace the button cell battery ⇒ [Replacing the button cell battery](#).

Synchronizing a vehicle key

1. Stand next to the vehicle.
2. Press the  button on the vehicle key twice, quickly.

Or:

1. Remove the emergency key ⇒ [Emergency key \(vehicle key without key bit\)](#).
2. If necessary, remove the cap from the driver's door handle ⇒ [Locking the front passenger door and rear doors in an emergency](#).
3. Press the  button on the vehicle key.
4. Unlock the vehicle using the emergency key.
5. Open the driver door.

If the vehicle is equipped with an anti-theft alarm system, the alarm will be triggered immediately ⇒ [Anti-theft alarm system](#).

6. Switch the ignition on.

Please note: To switch on the ignition, put the remote control vehicle key in the cup holder or in the storage compartment in the center console ⇒ [Troubleshooting](#).

This completes the synchronization.

Troubleshooting

Vehicle cannot be locked or unlocked

Remote control is disrupted by objects, poor weather conditions or transmitters on the same frequency band close to the vehicle (e.g. cell phones), as well as by a drained button cell.

The central locking switches off briefly to protect it from overloading.

1. Close the driver door.

Or: Synchronize the vehicle key ⇒ [Synchronizing a vehicle key](#).

Or: Change the battery cell in the vehicle key ⇒ [Replacing the button cell battery](#).

The indicator light is not blinking

If the indicator light in the vehicle key does not blink when you press one of the buttons, then the button cell battery in the vehicle key must be replaced.

 You can get an additional or replacement vehicle key from an authorized Volkswagen dealer or authorized Volkswagen Service Facility.

“Keyless Access” with push-button start

Introduction

Keyless Access makes it possible to unlock and lock the vehicle without actively using the key. A valid vehicle key must be present within the vicinity of the vehicle to use this function.

Unlocking or locking using Keyless Access

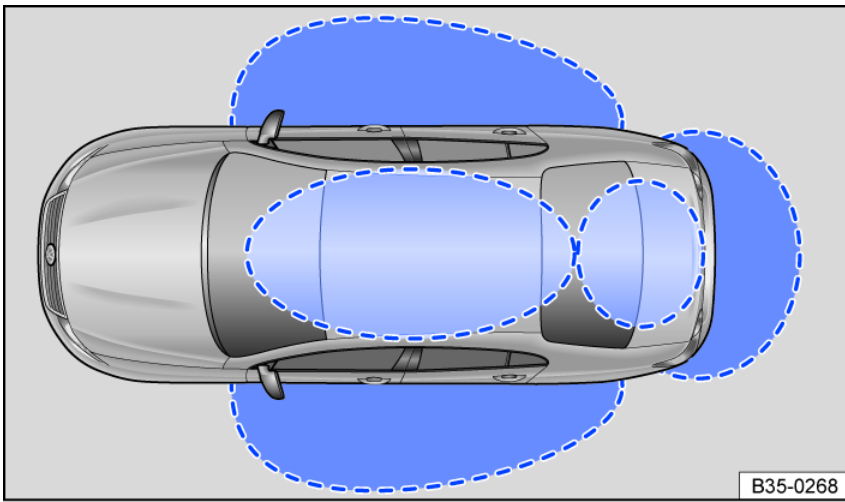

B35-0268

Fig. 51 Keyless Access: sensor range.

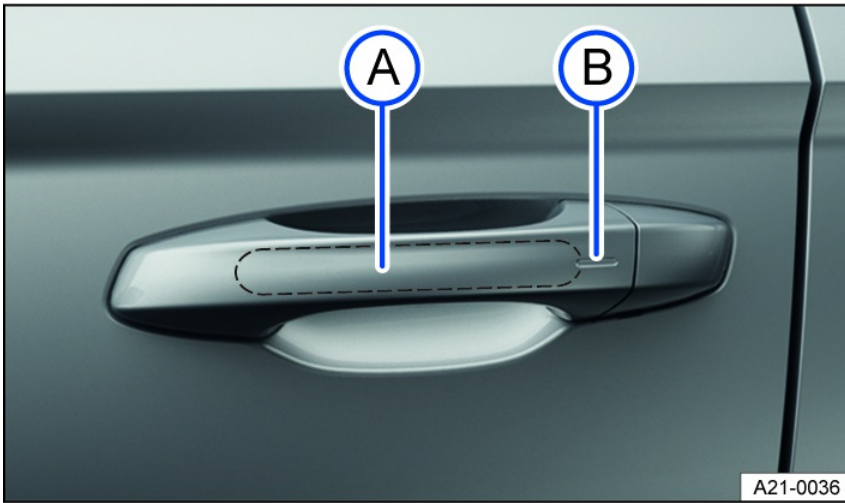

A21-0036

Fig. 52 In door handle: sensors.

- A Sensor on the inside of the driver or passenger door handle.
- B Sensor on the outside of the driver or passenger door handle.

Unlocking the vehicle

1. Touch the sensor on the inside of the driver or passenger door handle [fig. 52](#).

Locking the vehicle

1. Switch the ignition off.
2. Close the driver door or front passenger door.
3. Touch the sensor on the outside of the driver or passenger door handle [fig. 52](#).

The turn signals flash twice when unlocking and blink once when locking.

Unlocking and locking the trunk lid

If the vehicle is locked and a vehicle key is within the trunk lid sensor range, the trunk lid will unlock automatically when opened [fig. 51](#).

The trunk lid locks automatically after it closes.

The trunk lid will not lock automatically if the vehicle is completely unlocked.

Deactivating Keyless Access temporarily

You can temporarily deactivate Keyless Access using the following steps to prevent the vehicle from being unlocked and started by unauthorized people:

1. Lock the vehicle with the  button on the vehicle key.
2. Then, within five seconds of locking the vehicle, touch the sensor on the outside of the door handle once [fig. 52](#). Do not grasp the door handle during this process.

Keyless Access is now temporarily deactivated.

3. To check that it has actually been deactivated, wait at least 10 seconds and then pull on the door handle.

The door should not open.

The next time the vehicle is unlocked, you must use the vehicle key. Keyless Access will be reactivated the next time the vehicle is unlocked.

Operating convenience functions

The electric windows close automatically.

On vehicles with a tilting and sliding panoramic sunroof, the sunroof also closes.

1. Press and hold the sensor on the driver or passenger door handle for a few seconds *fig. 52*.

The sensor functions can be adjusted in the Vehicle settings menu in the Infotainment system.

 **The unlock function is deactivated for several seconds so that you can check if the vehicle locked correctly.**

 **If the sensor is touched twice, the entire vehicle will unlock even after a single door is unlocked.**

Troubleshooting

If Keyless Access is not working

The sensor function may be impaired if the sensor is dirty.

1. Clean the sensors.

If all turn signals flash four times

The vehicle key that was last used is still in the vehicle.

1. Remove the key and lock the vehicle.

Automatic sensor deactivation

The sensors will deactivate automatically under the following conditions:

- If the vehicle is not unlocked or locked for a long period of time
- If a sensor is triggered too frequently

Reactivating the sensor pads:

1. Unlock the vehicle using the  button on the vehicle key.

Valid vehicle key cannot be detected

The yellow indicator light turns on. A message will also appear in the instrument cluster display.

The vehicle key is no longer in the vehicle or within range of the sensors.

1. Do not switch the ignition off.
2. Bring the vehicle key back into the vehicle or within range of the sensors.

If the problem persists, contact an authorized Volkswagen dealer or authorized Volkswagen Service Facility. Volkswagen recommends contacting an authorized Volkswagen dealer or authorized Volkswagen Service Facility.

NOTICE

Strong streams of water or vapor could activate the sensors in the door handles if a valid vehicle key is located near the vehicle. If at least one window is open and the sensors in one door handle are permanently activated, then all windows will close. If the stream of water or vapor is removed briefly from the sensor in a door handle and then redirected at the sensor, all of the windows may open.

 **If the message Keyless faulty. appears in the instrument cluster display, there may be a malfunction in the Keyless Access system. Contact an authorized Volkswagen dealer or authorized Volkswagen Service Facility. Volkswagen recommends contacting an authorized Volkswagen dealer or authorized Volkswagen Service Facility.**

Doors and central locking button

Introduction

The doors can be manually locked and in some cases unlocked, for example if the vehicle key or the central locking system is malfunctioning.

The central locking system allows you to unlock and lock all doors, the trunk lid, and the fuel filler flap from one location.

The vehicle can be locked when the ignition has been switched off or if the driver has exited the vehicle when the engine is stopped.

An image in the instrument cluster display indicates if one or more doors have not opened or closed correctly \Rightarrow *Driver information.*  **Do not continue driving!** Open the respective door and close it again.

The image is also displayed when the ignition is switched off, and it turns off several seconds after the doors are closed and the vehicle has been locked.

WARNING

If a door is not closed correctly, it can open suddenly while driving and cause serious injuries.

- Stop immediately and close the door.
- When closing the door, make sure it engages securely and completely. When closed, the door must be flush with the areas of the vehicle body that are around the door.
- Do not open or close the doors if anyone is in the way.

WARNING

When the door is being held open by the door arrester, it may close by itself in high winds or on inclines, which can cause injuries.

- Always hold the door handle firmly when opening and closing the door.

WARNING

The area within the range of motion for the doors and trunk lid can be dangerous and there is the potential for injuries.

- Do not open or close the doors and trunk lid if anyone is in the way.

WARNING

Locking the doors carelessly can cause serious injuries.

- When the vehicle is locked from the outside, the doors and power windows cannot be opened from the inside.
- The central locking system locks all the doors. When the vehicle is locked from the inside, it reduces the risk of opening the doors unintentionally and of unauthorized people entering the vehicle. In case of an emergency or an accident, locked doors can make it more difficult for first responders to access the vehicle interior to help the passengers.
- Never leave children or people requiring assistance in the vehicle. All doors can be locked from the inside using the central locking button. This can result in locking yourself inside the vehicle. Individuals locked in the vehicle could be exposed to very high or very low temperatures.
- Depending on the season, the temperature inside the vehicle could become very high or low, which can lead to serious injuries, illness or death, especially for very young children.
- Never leave anyone in a locked vehicle. In an emergency, these people may not be able to exit the vehicle without assistance or help themselves.

NOTICE

When using the emergency locking or emergency unlocking feature, remove and reinstall the affected parts carefully and correctly to reduce the risk of vehicle damage.

Indicator light in the driver's door

 Please read the introductory information and heed the Warnings and Notice ⇒  and  Introduction.

The indicator light for the central locking system is located in the driver door ⇒ *Driver door*.

Vehicle is locked: the red LED light blinks for approximately two seconds, and then flashes more slowly after that. The indicator light does not flash if the vehicle was locked using the central locking button in the driver's door ⇒ *Central locking button*.

Automatic locking and unlocking

 Please read the introductory information and heed the Warnings and Notice ⇒  and  Introduction.

Depending on how your vehicle is equipped, settings for the central locking can be configured in the Vehicle settings menu in the Infotainment system.

Automatic locking (Auto Lock)

The vehicle locks automatically at speeds of about 9 mph (15 km/h) or higher. If the vehicle is locked, the  indicator light will turn yellow in the central locking button.

Automatic unlocking (Auto Unlock)

If one of the following conditions apply, all doors and the trunk lid will unlock automatically:

- For vehicles with an automatic gearbox: The parking lock **P** is engaged and the ignition is switched off.
- Or: if the door handle has been pulled.
- Or: if airbags have deployed during a collision ⇒ *Troubleshooting*.

 The Auto Unlock function makes it possible for first responders to access the inside of the vehicle.

Central locking button

📖 Please read the introductory information and heed the Warnings and Notice ⇒ ⚠️ and ⓘ Introduction.



Fig. 53 In the driver's door: Central locking button (general example).

ⓘ Central locking button.



Fig. 54 In the driver's door: Button for powered opening of the trunk lid (general example).

ⓘ Button for powered opening of the trunk lid.

🔓 – Unlock the vehicle.

🔒 – Lock the vehicle.

🚗 – Open the trunk lid.

The central locking button functions both when the ignition is on or off, but only when all the doors are closed.

If the 🚗 button in the driver door is pressed, only the trunk lid will open. All doors remain locked.

If the vehicle is locked from the outside using the vehicle key, the central locking buttons will be disabled.

If the vehicle is locked from the inside using the central locking button, then:

- The 🔒 indicator light in the button will turn yellow if all doors are closed and locked.
- The anti-theft alarm system will not be activated ⇒ [Anti-theft alarm system](#).

The doors can be opened from the inside by pulling the door handle. The 🔒 indicator light in the button turns off. The unopened doors and the trunk lid will remain locked and cannot be opened from the outside.

Opening and closing the driver's door in an emergency

📖 Please read the introductory information and heed the Warnings and Notice ⇒ ⚠️ and ⓘ Introduction.

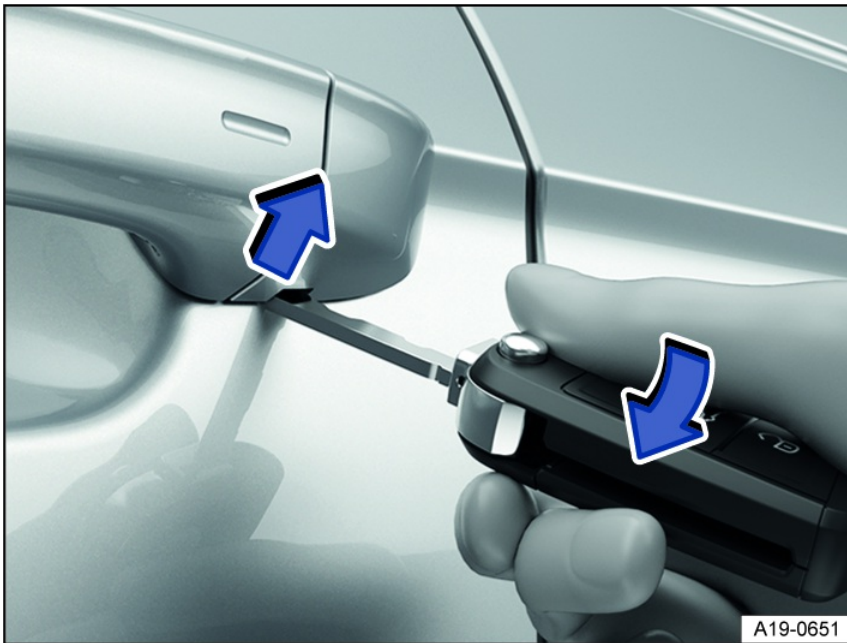

Fig. 55 Driver's door handle: prying off the cap.

Generally, all doors will lock when locking manually. Only the driver door will unlock when unlocking manually.

Note the information about the anti-theft alarm system ⇒ *Anti-theft alarm system*.

1. Remove the emergency key from the vehicle key ⇒ *Emergency key (vehicle key without key bit)* .
2. On the driver door handle, insert the mechanical key from below into the opening on the cover *fig. 55* (arrow).
3. Pull on the driver door handle, carefully removing the cover by pulling upwards from below.
4. Insert the mechanical key into the lock cylinder and lock or unlock the vehicle. If necessary, also pull the driver door handle slightly.
5. Push the mechanical key into the opening on the vehicle key until the mechanical key locks in place ⇒ *Emergency key (vehicle key without key bit)* .
6. Pull on the driver door handle and fit the cover onto the lock cylinder from the back to the front.

Special considerations for manual unlocking

- An alarm is triggered when the driver's door is opened ⇒ *Anti-theft alarm system*.
- An emergency start must be performed after unlocking ⇒ *Troubleshooting*.
- Switch the ignition on to turn off the alarm.

The electronic immobilizer will detect a valid vehicle key.

 The anti-theft alarm system is not activated when the vehicle is manually locked using the key bit ⇒ *Anti-theft alarm system*.

Locking the front passenger door and rear doors in an emergency

 Please read the introductory information and heed the Warnings and Notice ⇒  and  *Introduction*.



Fig. 56 In the front edge of the rear right-hand door: Vehicle emergency lock for using the emergency (mechanical) key.

The front passenger door and the rear doors can each be locked manually.

The anti-theft alarm system is not activated when this happens ⇒ *Anti-theft alarm system*.

1. Open the door.
2. Remove the rubber seal  in the front of the door.
3. Insert the emergency key in the vertical slot and turn it inwards *fig. 56*.
4. Reattach the rubber seal.
5. Check that the door is locked.
6. Have the vehicle checked immediately by a suitably qualified professional. Volkswagen recommends contacting an authorized Volkswagen dealer or authorized Volkswagen Service Facility.

If a door is locked manually, it will unlock again when the vehicle is unlocked or if that door is opened from the inside.

 **Doors can be unlocked and opened from the inside by pulling the door handle.**

Child safety lock

 Please read the introductory information and heed the Warnings and Notice ⇒  and  *Introduction*.

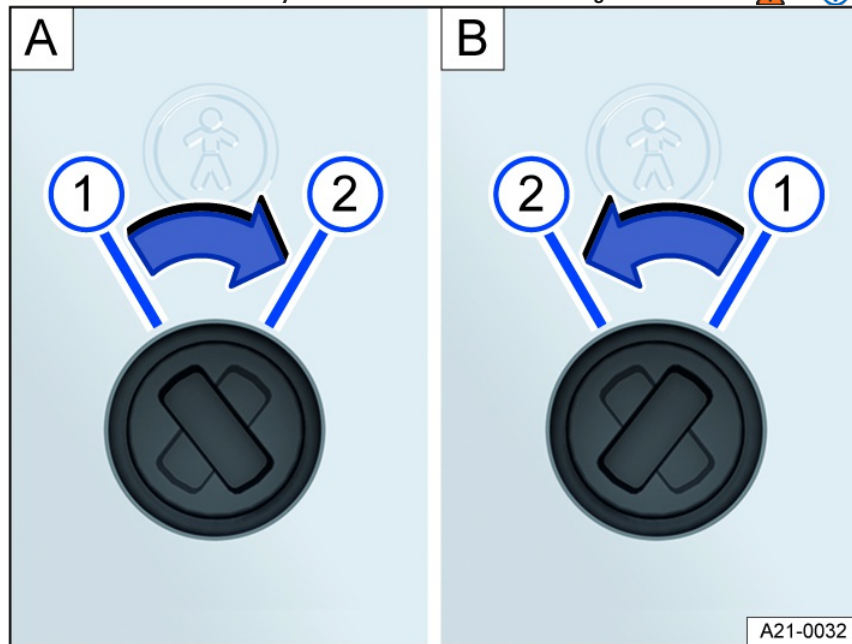

Fig. 57 Child safety lock: [A] left rear door, [B] right rear door.

- ① Child safety lock is switched off.
- ② Child safety lock is switched on.

The child safety locks are located on the inner door panels of the rear doors.

The child safety lock reduces the risk of the rear doors being opened from the inside.

When the child safety lock is switched on, the door can only be opened from the outside.

Switching the child safety lock on or off



1. Unlock the vehicle the open the respective rear door.
2. Bring the slot into the corresponding position *fig. 57*.

WARNING

When the child safety lock is switched on, that door cannot be opened from the inside.

- Never leave children or people requiring assistance unattended in the vehicle when the doors are locked. Otherwise, they could become locked inside the vehicle. In case of an emergency, these individuals would not be able to leave the vehicle without assistance or care for themselves. Individuals locked in the vehicle could be exposed to very high or very low temperatures.
- Depending on the season, the temperature inside the vehicle could become very high or low, which can lead to serious injuries, illness or death, especially for very young children.

Troubleshooting

 Please read the introductory information and heed the Warnings and Notice ⇒  and  Introduction.

If the indicator light does not turn off

The red LED in the vehicle door flashes briefly and then stays on.

There is a malfunction in the locking system.

1. Contact a suitably qualified professional. Volkswagen recommends contacting an authorized Volkswagen dealer or authorized Volkswagen Service Facility.

If the turn signals are not flashing

The turn signals are not blinking as confirmation when locking the vehicle:

1. Check whether all of the doors and the trunk lid and engine hood are closed.
2. Close any doors and trunk lid or engine hood that are not closed.

If the vehicle is locking automatically

The vehicle will lock again automatically after approximately 45 seconds if one of the following conditions apply:

- The vehicle was unlocked, but not opened
- The ignition was not switched on
- The trunk lid was not opened.

Locking with a second vehicle key

For vehicles with Keyless Access with push-button start: If a second vehicle key is used to lock the vehicle from outside, the vehicle key inside the vehicle is immediately disabled so that it cannot be used to start the engine; it is still possible to perform an emergency start, however.

1. Press the  button on the remote control vehicle key inside the vehicle to enable the vehicle key inside the vehicle so that it can be used for to start the engine as usual.

Locking the vehicle after an airbag deploys

The entire vehicle unlocks when an airbag deploys in a collision. Depending on the severity of the damage, it may be possible to lock the vehicle as follows after the collision:

1. Switch the ignition off.
2. Open the driver door and shut it again.
3. Lock the vehicle.

NOTICE

Strong streams of water or vapor could activate the sensors in the door handles if a valid vehicle key is located near the vehicle. If at least one window is open and the sensors in one door handle are permanently activated, then all windows will close.

 It may not be possible to unlock or lock the vehicle using Keyless Access if the 12 V vehicle battery or button cell battery in the vehicle is weak or drained. The vehicle can be manually unlocked or locked.

 If there is no valid vehicle key in the vehicle or one is not detected, a message will appear in the instrument cluster display. This can occur if another signal interferes with the remote control vehicle key or if the remote control vehicle key is covered by an object, such as a metal case.

Anti-theft alarm system

The vehicle may be equipped with an anti-theft alarm system.

The anti-theft alarm system monitors the doors, the hood, and the trunk lid.

The anti-theft alarm system is automatically activated when you lock the vehicle.

If an attempt is made to access the vehicle without using the appropriate vehicle key, this triggers the anti-theft alarm system, which emits audible and visual warning signals for up to five minutes.

When is the alarm triggered?

- If a door that was unlocked manually using the vehicle key is opened.
- If the hood is opened.
- If the trunk lid is opened.
- If the ignition is switched on with an invalid vehicle key.

Switching off the alarm

1. Unlock the vehicle with the  unlock button on the vehicle key.
2. Grasp the door handle ⇒ "Keyless Access" with push-button start.

3. Switch the ignition on.

 The anti-theft alarm system will not work correctly if the 12 V vehicle battery is weak or drained.

 Disconnecting the 12 V vehicle battery may set off the anti-theft alarm system.

 If you have integrated a trailer into the anti-theft alarm system, breaking the connection to the trailer may trigger the anti-theft alarm system ⇒ [Trailer towing](#)

Trunk lid

Introduction

The trunk lid is unlocked and locked together with the doors.

On vehicles with Keyless Access, the trunk lid is automatically unlocked when opening ⇒ *“Keyless Access” with push-button start*.

If individual door opening or the opening of one side of doors is activated in the Infotainment system settings for opening and closing, you must press the  but on the remote control vehicle key twice to unlock the trunk lid.

On vehicles with Keyless Access you must press the sensor on the inside of the driver's or front passenger's door handle twice to do this.

WARNING

Uncontrolled or unintentional release: opening and closing the trunk lid can cause accidents and serious injuries.

- Do not open or close the trunk lid if anyone is in the way.
- After closing the trunk lid, check that it is properly closed. When closed, the trunk lid must be flush with the areas of the vehicle body that are around the door.
- Always keep the trunk lid closed while driving.
- Never open the trunk lid when cargo is secured on it, such as bicycles. Additional weight can cause the trunk lid to begin closing by itself. If necessary, prop the trunk lid open or remove the cargo beforehand.
- Close and lock the trunk lid and all doors when the vehicle is not in use. Make sure that no one remains in the vehicle.
- Never let children play in or on the vehicle unattended, especially when the trunk lid is open. Children could enter the luggage compartment, close the lid, and then lock themselves in. Depending on the season, the temperature inside the vehicle could become very high or low, which can lead to serious injuries, illness or death, especially for very young children.

WARNING

Unlocking or opening the trunk lid incorrectly or carelessly may lead to serious injuries.

- The vehicle may not always detect when the trunk lid is not latched if a cargo rack that is carrying cargo is mounted on the trunk lid. If the trunk lid is not latched, it may open suddenly while driving.

WARNING

If there is a heavy load of snow or cargo on the trunk lid, the additional weight may cause the lid to lower, which can result in serious injuries.

- Never open the trunk lid if there is a heavy load of snow or cargo such as a cargo rack on it.
- Remove the snow or cargo before opening the trunk lid.

WARNING

Do not press on the rear window of the trunk lid with your hand. The rear window could crack, which can result in injuries.

NOTICE

Never attach or secure cargo on the opening mechanisms. This could cause damage that could prevent the trunk lid from closing.

NOTICE

Never attach cargo to the rear spoiler or use the rear spoiler to hold cargo in place. This could cause damage that could result in the rear spoiler breaking off.

Opening and closing the trunk lid

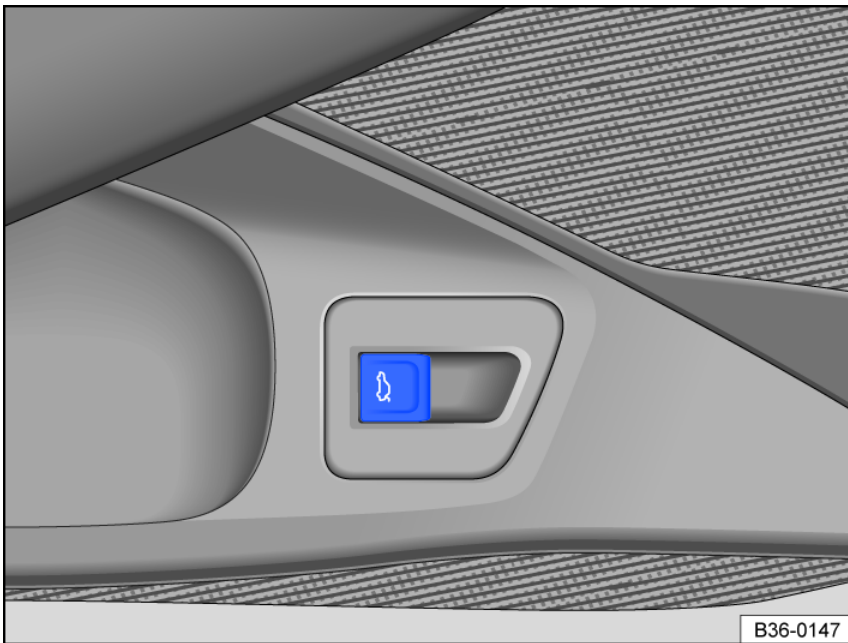

 Please read the introductory information and heed the Warnings and Notice ⇒  and  Introduction.



B36-0147

Fig. 58 In the driver's door: unlock button for the trunk lid.

Opening the trunk lid

1. Press the  button on the vehicle key.
 Or: pull the  button in the driver door upward *fig. 58*.
 Or: press on the top of the Volkswagen emblem.

The trunk lid will open automatically.

Closing the trunk lid

1. Pull the trunk lid downward firmly using the handle in the interior trim panel until it latches shut in the lock ⇒ .

The trunk lid will also lock when the doors are locked.

An image in the instrument cluster display indicates if the trunk lid has not opened or closed correctly.

The trunk lid locks automatically while driving.



WARNING

Closing the trunk lid incorrectly or carelessly may lead to serious injuries.

- When closing the trunk lid, make sure your hands are not within the closing range of the lid.
- When opening the trunk lid, take care to pull it all the way up.

 If the trunk lid is not opened within several minutes after unlocking, it will lock again automatically.

Power opening and closing the trunk lid

 Please read the introductory information and heed the Warnings and Notice ⇒  and  Introduction.

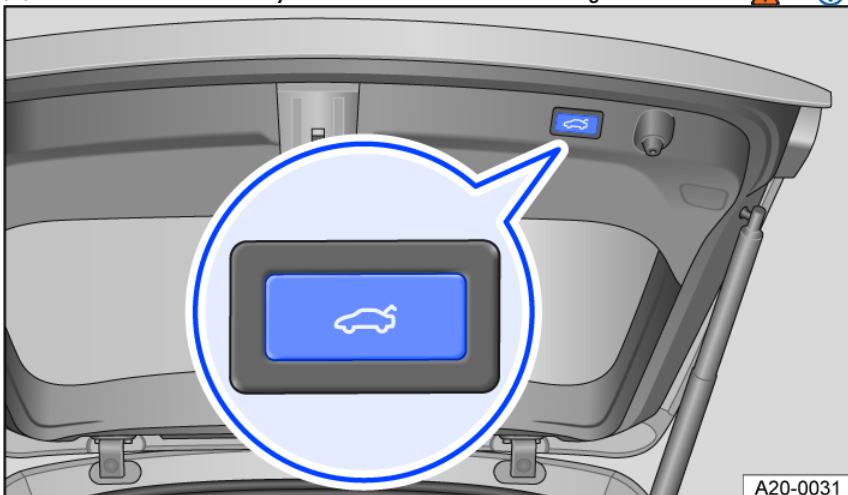

A20-0031

Fig. 59 In the open trunk lid: Button for power closing the trunk lid.

Power opening the trunk lid

1. To unlock the trunk lid, press and briefly hold the  button on the remote control vehicle key.

Or: pull the  button in the driver door upward.

Or: press on the top of the Volkswagen emblem.

The trunk lid will open automatically.

Power closing the trunk lid

1. Press the button in the trunk lid when it is open *fig. 59*.

Or: pull the  button in the driver door upward when the ignition is switched on until the trunk lid is closed.

Or: *On vehicles with Keyless Access with push-button start:* briefly press and hold the  button on the vehicle key. The vehicle key must be nearby to use this feature.

Or: press on the top of the Volkswagen emblem.

Or: Begin closing the trunk lid by hand until it closes by itself.

The trunk lid is closed.

Interrupting the opening or closing process

1. Press the  button while the lid is opening or closing.

Or: press on the top of the Volkswagen emblem while the lid is opening or closing.

The trunk lid can now be moved by hand. It is necessary to use more force when doing this.

Pressing the  button again moves the trunk lid back to the original position.

Chimes

When the trunk lid is opened or closed from inside the vehicle or using the vehicle key, chimes will sound.

Changing and saving the opening angle

If the space behind or above the vehicle is not large enough to allow the trunk lid to open completely, you can change how far the trunk lid opens.

1. Interrupt the opening process at the desired open position. It must be at least half open.

2. Press and hold the  button in the trunk lid until the emergency flashers start blinking *fig. 59*.

The adjusted opening angle is saved.

There will be an audible signal and the emergency flashers will flash to indicate that the setting was saved.

Resetting and saving the opening angle

For that the trunk lid to open fully again, the opening angle must be reset and saved again.

1. Push the open trunk lid all the way up by hand. It is necessary to use more force when doing this.

2. Press and hold the  *fig. 59* button in the trunk lid until the emergency flashers start blinking.

This resets the opening angle.

An audible signal will sound and the emergency flashers will flash to indicate that the process is completed.

! NOTICE

Check that there is enough space to open or close the trunk lid before opening or closing it, for example if the vehicle is in a garage.

Trunk lid with Easy Open motion sensor

 Please read the introductory information and heed the Warnings and Notice  and  Introduction.

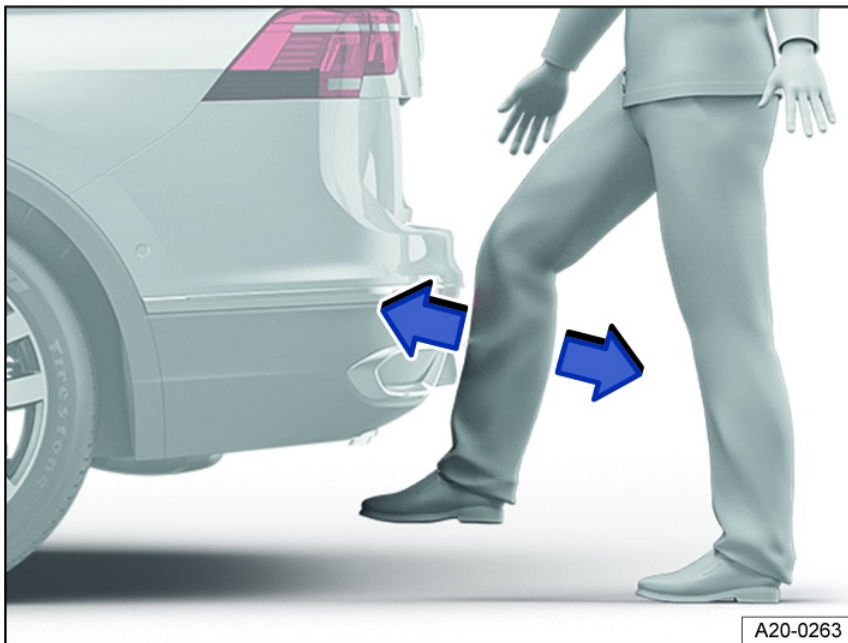

Fig. 60 General example of the sensor-controlled luggage compartment opener (Easy Open).

If a valid vehicle key is located near the trunk lid, the trunk lid can be unlocked and opened with foot motion.

1. Position your foot behind the middle of the bumper.
2. Quickly swing the lower part of your leg close to the bumper *fig. 60*.
3. Quickly remove the lower part of your leg once more from the bumper.

Visual feedback is given via the turn signals. The trunk lid will open.

Activating or deactivating the Easy Open function

The Easy Open function can be activated and deactivated in the infotainment system:

1. Select the Vehicle menu.
2. Select the Exterior submenu.
3. Swipe to the side and activate or deactivate Easy Open.

Or:

1. Swipe to the side and select the Central locking menu item.
2. Scroll down the list and activate or deactivate Easy Open.

If Easy Open is activated, Easy Close is also active, depending on the vehicle equipment ⇒ *Automatic trunk lid closing Easy Close*.

The Easy Open function is only available when Keyless Access is activated ⇒ *“Keyless Access” with push-button start*.

⚠ CAUTION

If a valid vehicle key is detected near the trunk lid, the Easy Open function may trigger unintentionally and open the trunk lid, for example if there is a sweeping motion under the rear bumper, if a strong stream of water or steam passes by the bumper, or during maintenance and repair work in the rear bumper area. If the trunk lid opens unintentionally, it may cause injuries to people and/or damage to objects within the trunk lid's range of motion.

- Always make sure that no valid vehicle keys are left unattended near the trunk lid.
- Always turn off the Easy Open function via the Infotainment system before any and all maintenance and repair work is performed on the vehicle.
- Always turn off the Easy Open function via the Infotainment system before washing the vehicle.
- Always turn off the sensor-controlled luggage compartment opener (Easy Open)/Easy Close function via the Infotainment system before mounting a bicycle rack or hitching a trailer ⇒ *Introduction*.

Automatic trunk lid closing Easy Close

📖 Please read the introductory information and heed the Warnings and Notice ⇒ ⚠ and ⚠ *Introduction*.

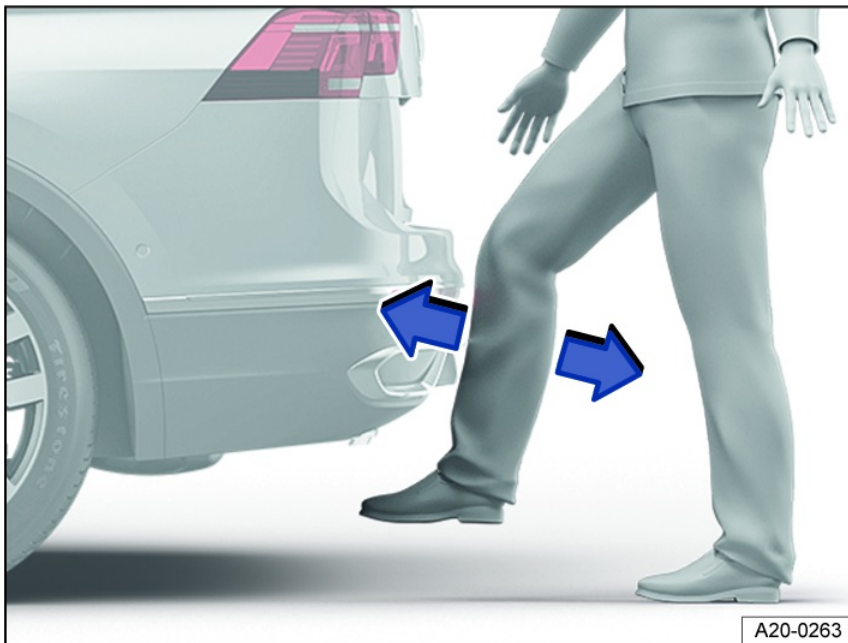

Fig. 61 General example of the trunk lid with sensor-controlled closing (Easy Close).

You can only activate the Easy Close function if a valid remote control vehicle key is detected near the trunk lid.

1. Position your foot behind the middle of the bumper.
2. Quickly swing the lower part of your leg close to the bumper *fig. 61*.
3. Quickly remove the lower part of your leg once more from the bumper.

Easy Close is activated for approx. 20 seconds. A chime will confirm successful activation.

The trunk lid is closed as soon as all valid vehicle keys are removed from the area near the trunk lid.

The trunk lid will lock automatically after it closes if the vehicle was previously locked and there is not a valid vehicle key inside the vehicle.

Easy Close permits locking a maximum of one vehicle key in the luggage compartment.

The locking procedure is interrupted as soon as a vehicle key returns nearby. The trunk lid re-opens.

Activating or deactivating the Easy Close function

The function Easy Close can be activated or deactivated together with the sensor-controlled luggage compartment opener (Easy Open) function in the Vehicle menu in the Infotainment system ⇒ *Trunk lid with Easy Open motion sensor*.

The Easy Close function is only available when Keyless Access is activated ⇒ *“Keyless Access” with push-button start*.

⚠ CAUTION

If a valid vehicle key is detected near the trunk lid, the Easy Close function may trigger unintentionally and close the trunk lid, for example if there is a sweeping motion under the rear bumper, or during maintenance and repair work in the rear bumper area. If the trunk lid closes unintentionally, it may cause injuries to people and/or damage to objects within the trunk lid's range of motion.

- Always make sure that no valid vehicle keys are left unattended near the trunk lid.
- Always make sure that there are no people in the swivel range of the trunk lid.
- Do not hold on to anything in the path of the trunk lid.
- Always switch off the Easy Close function via the Infotainment system before any and all maintenance and repair work is performed on the vehicle.
- Always switch off the Easy Close function via the Infotainment system before washing the vehicle.
- Always switch off the Easy Close function via the Infotainment system before mounting a bicycle rack or hitching a trailer ⇒ *Introduction*.

ⓘ If another trunk lid function is activated while closing the trunk lid or objects are detected in the area of the trunk lid, the closing process is automatically interrupted.

ⓘ If the vehicle is locked and the Easy Close function is started, the trunk lid will lock automatically once it is closed. If the vehicle is completely unlocked and the Easy Close function is started, the trunk lid will not lock automatically once it is closed.

Mechanically unlocking the trunk lid using the emergency release

📖 Please read the introductory information and heed the Warnings and Notice ⇒ **⚠** and **ⓘ** *Introduction*.

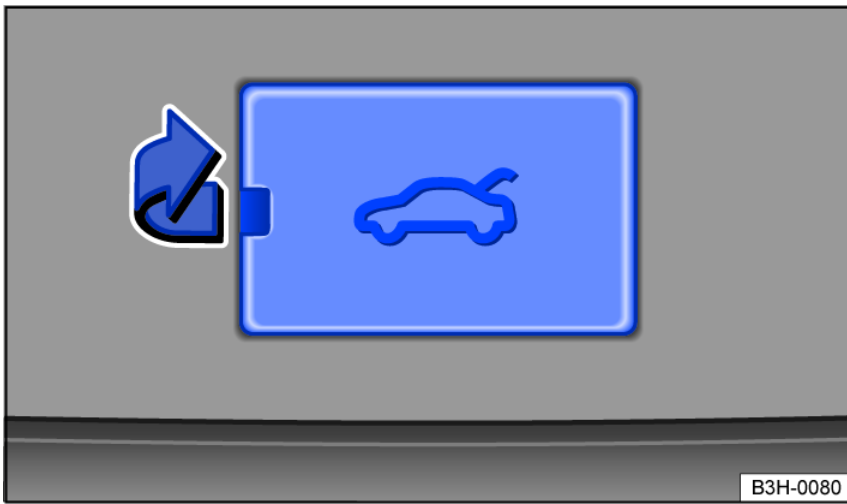

B3H-0080

Fig. 62 In the trunk lid: cover for the trunk lid emergency release.



A22-0005

Fig. 63 In the luggage compartment: trunk lid emergency release.

Mechanically unlocking the trunk lid using the emergency release

1. Pry off the square cover in the inner trim panel of the trunk lid using a screwdriver *fig. 62*.
2. Place a suitable object in the opening for the release lever and press in the direction of the arrow to release the trunk lid *fig. 63*.
3. You will need to use more force to open the trunk lid.

Troubleshooting

📖 Please read the introductory information and heed the Warnings and Notice ⇒ ⚠️ and ⚠️ Introduction.

If the trunk lid will not open or close

1. Check if the trunk lid is being blocked by an object.

The trunk lid can be moved by hand. It is necessary to use more force when doing this.

- If the trunk lid is operated too frequently within a short period of time, then the lid motor will automatically switch off to reduce the risk of overheating. Until the motor has cooled down, the trunk lid can be opened and closed by hand using extra force.
- When in trailer mode, the power trunk lid can only be opened and closed at the trunk lid.
- If the 12-volt vehicle battery or fuse is disconnected or malfunctioning, the trunk lid must be closed by hand.

If all turn signals flash four times

The vehicle key that was last used is still in the vehicle.

1. Remove the key and lock the vehicle.

If the trunk lid is difficult to move

The mechanism for opening the trunk lid may not always work automatically when the outside temperatures are around the freezing point.

1. Guide the trunk lid farther upward by hand.

The Easy Open sensor function is not working

- Easy Open only works when the ignition is switched off.
- Clean the sensors in the rear bumper.
- The trailer hitch is extended.
- The vehicle was retrofitted with a trailer hitch.
- Easy Open (sensor-controlled luggage compartment opener) may be deactivated in heavy precipitation to reduce the risk of false activation.

Automatic trunk lid closing Easy Close does not work

- Switch the ignition off and close the driver door.
- The trunk lid must be open at least half way.
- Disconnect the trailer ⇒ *Trailer towing*.
- There is more than one vehicle key in the luggage compartment.
- Press the Easy Close button again.

Windows

Opening and closing the windows

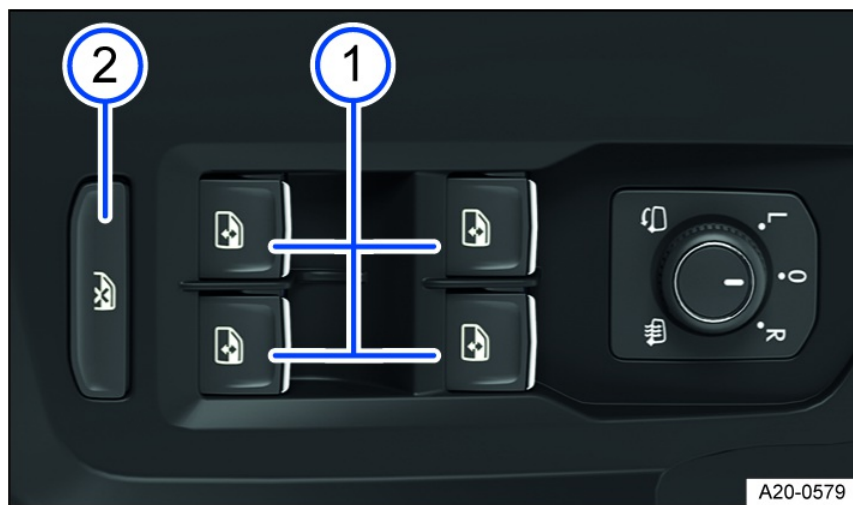

Fig. 64 In the driver door: Power window buttons.

- ① Opening the window: press the switch.
Closing the window: pull the switch.
- ② Deactivating the power window buttons in the rear doors: press the switch.
This button is only located in the driver door.

The windows can still be opened or closed using the switches in the doors for a brief period after the ignition has been switched off, as long as the driver's or front passenger door is not opened.

One-touch opening and closing function

The one-touch opening and closing function allows the windows to be completely opened or closed. To use this feature, do not hold the window switch up or down.

- To start the one-touch closing function, pull the window switch upward briefly to the second level.
- To start the one-touch opening function, press the window switch downward briefly to the second level.
- To stop the one-touch opening or closing function, pull or press the switch for that window again.

Convenience opening and closing

Opening

The windows can be opened from outside the vehicle using the vehicle key when the ignition is switched off.

1. Press and hold the unlock button on the vehicle key.
2. To stop the function, release the unlock button.

Closing

1. *On vehicles with Keyless Access with push-button start*: press the sensor surface or locking button on the door handle for a few seconds, until the windows are closed ⇒ *"Keyless Access" with push-button start*. The vehicle key must be nearby to use this feature.

When all of the windows and the power sunroof are closed, the turn signals will blink *once* as a confirmation.

2. To stop the function, remove your finger from the sensor or switch.

You can select the convenience opening settings in the Vehicle settings menu in the Infotainment system.

WARNING

Careless or unintended use of the power windows can cause serious injuries.

- Do not open or close the power windows if anyone is in the way.
- Never leave children or people requiring assistance unattended in the vehicle when the vehicle is locked. The windows cannot open in an emergency situation.
- Always take all vehicle keys with you when leaving the vehicle. The windows can still be opened or closed using the switches in the doors for a brief period after the ignition has been switched off, as long as the driver's or front passenger door is not opened.
- When driving with children seated on the rear bench seat, always disable the rear power windows so that the windows cannot be opened or closed.

NOTICE

If the windows are open, rain could enter the vehicle and soak the interior, causing vehicle damage.

 **If the power windows are malfunctioning, the one-touch opening and closing function and the pinch protection may not function correctly. Contact a suitably qualified professional. Volkswagen recommends contacting an authorized Volkswagen dealer or authorized Volkswagen Service Facility.**

 **Convenience opening and closing only functions if the one-touch opening and closing function is activated for all the power windows.**

Power window pinch protection

The power window pinch protection can reduce the risk of being pinched and injured when the windows are closing.

If the window cannot close due to resistance or an obstacle, then the window will reopen immediately ⇒ .

1. Check why the window did not close.
2. Try again to close the window.

If the window will not close again, then the pinch protection will be disabled for several seconds.

If the window still cannot close, then the window will stop at the place where it meets resistance. If you press the switch again within several seconds, the window will close without pinch protection ⇒ .

Closing windows without pinch protection

1. Try to close the windows again within a few seconds by holding the switch. This will disable the pinch protection.

If the closing process takes longer than several seconds, then pinch protection will be enabled again. If there is resistance to the window moving or an obstacle is blocking the window, then the window will reopen automatically.

2. If the window still cannot close, then contact a suitably qualified professional. Volkswagen recommends contacting an authorized Volkswagen dealer or authorized Volkswagen Service Facility.

WARNING

Closing the window when pinch protection is disabled can result in serious injuries.

- Always be careful when closing the windows.
- Never allow anyone to be in the window operating area, especially if a window is closing when pinch protection is disabled.
- The pinch protection does not prevent fingers or other parts of the body from becoming injured by being pressed against the window frame.

 **Pinch protection also occurs when using the convenience closing function with the vehicle key.**

Troubleshooting

One-touch up/down feature

If the 12 V vehicle battery is disconnected or drained when the windows are not completely closed, then the one-touch up/down feature will not work. It must be reprogrammed using the following steps:

1. Switch the ignition on.
2. Close all windows and doors.
3. Pull the switch for the desired window and hold it in that position for several seconds.

4. Release the switch, then pull it upward again and hold it.

The one-touch up and down features will then be fully functional.

The automatic power windows can be reprogrammed individually, or multiple windows can be reprogrammed at the same time.

Controls are responding differently than expected

Moisture, dirt and grease may limit the functioning of the controls.

1. Always keep the control panels clean and dry.

Sunroof

Opening and closing the tilting and sliding panoramic sunroof

The term "sunroof" is used as a synonym for the panoramic sliding/tilting sunroof.

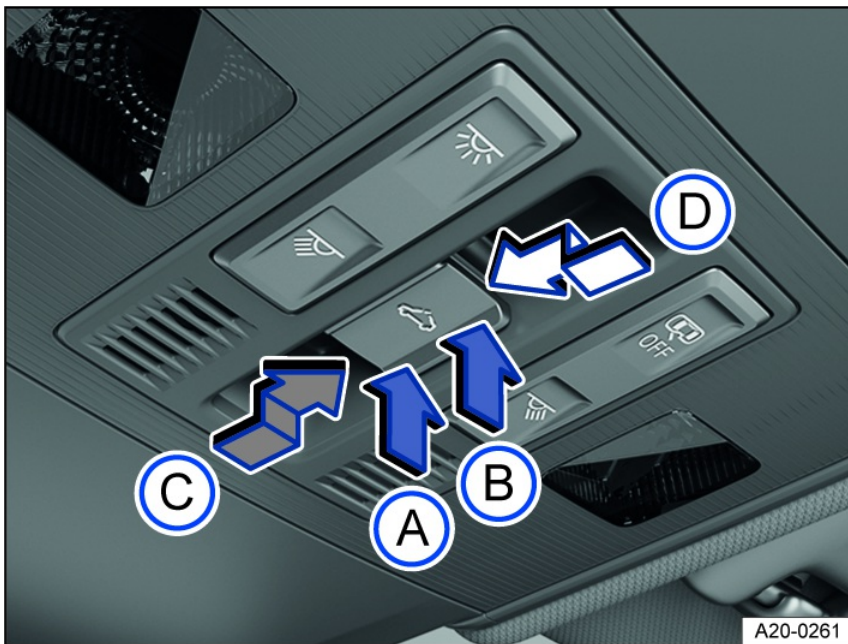



Fig. 65 In the headliner: sunroof button.

- (A) Close the power sunroof when tilted.
- (B) Tilt the power sunroof.
- (C) Open the power sunroof or stop the automatic process.
- (D) Close the power sunroof or stop the automatic process.

The  button has two levels.

First level: tilt, open, or close the sunroof completely or partially.

Second level: automatically open or close the sunroof completely.

You can stop the automatic process by pressing the button again.

Tilting the power sunroof

- Manual process: press the [fig. 65](#) button until the first level is reached.
- Automatic process: press the [fig. 65](#) button until the second level is reached.

Closing the power sunroof when tilted

- Manual process: press the [fig. 65](#) button until the first level is reached.
- Automatic process: press the [fig. 65](#) button until the second level is reached.

Opening the power sunroof

- Manual process: press the [fig. 65](#) button until the first level is reached.
- Automatic process up to comfort position: press the [fig. 65](#) button until the second level is reached.

Closing the power sunroof

- Manual process: press the [fig. 65](#) button until the first level is reached.
- Automatic process: press the [fig. 65](#) button until the second level is reached.

Stopping the automatic opening or closing process

1. Press the *fig. 65* or *fig. 65* button again.

WARNING

Careless or inattentive use of the sunroof can cause serious injuries.

- Do not open or close the power sunroof if anyone is in its path.
- Always take all vehicle keys with you when leaving the vehicle.
- Never leave children or people requiring assistance unattended in the vehicle, especially if they have access to the vehicle key. Inattentive use of the vehicle key can lock the vehicle, start the engine, switch the ignition on, or operate the sunroof.
- The sunroof can still be opened or closed for a brief period after the ignition has been switched off, as long as the driver's or front passenger's door has not been opened.

NOTICE

- To reduce the risk of damage, remove ice and snow from the vehicle roof before opening or tilting the power sunroof in winter weather.
- Always close the power sunroof before leaving the vehicle and when there is precipitation. If the sunroof is open or tilted, rain or snow could enter the vehicle interior and cause extensive damage to the electrical system. This could also result in further vehicle damage.
- Keep the power sunroof closed when using the roof rack.

 Remove leaves and other loose objects from the power sunroof guide rails regularly, either by hand or with a vacuum cleaner.

 The pinch protection will not function correctly if the sunroof is malfunctioning. Contact a suitably qualified professional. Volkswagen recommends contacting an authorized Volkswagen dealer or authorized Volkswagen Service Facility.

Tilting and sliding panoramic sunroof convenience opening and closing

Convenience opening and closing

The sunroof can be opened and closed from outside the vehicle using the vehicle key.

- Does not apply to the US or Canada: Press and hold the unlock or lock button on the vehicle key. The sunroof will be tilted or closed.
- For vehicles with Keyless Access with push-button start: Hold your finger on the unlock sensor in the door handle for several seconds until the tilting and sliding panoramic sunroof is closed ⇒ *Unlocking or locking using Keyless Access*.
- Remove your finger from the unlock or lock button to stop the function.

When using the convenience closing function, all windows in the doors and the sunroof will be closed. When all of the windows and the power sunroof are closed, the turn signals will blink once as a confirmation.

Settings for the sunroof can be adjusted in the vehicle settings in the Infotainment system ⇒ *Driver information*.

Sunroof pinch protection

The pinch protection reduces the risk of pinching injuries ⇒ . If the sunroof is obstructed while it is closing, it will open again automatically.

1. Check why the sunroof is not closing.
2. Try again to close the sunroof.
3. If the sunroof is still not able to close, close the sunroof without pinch protection.

Closing the sunroof without pinch protection

1. Press the  button to the second level until the sunroof is completely closed ⇒ *Opening and closing the tilting and sliding panoramic sunroof*.

This will close the sunroof without pinch protection.

2. If the power sunroof still cannot close, then contact a suitably qualified professional. Volkswagen recommends contacting an authorized Volkswagen dealer or authorized Volkswagen Service Facility.

If you release the switch during the closing process, then the sunroof will open again automatically.

WARNING

Closing the sunroof without pinch protection may result in serious injuries.

- Always be careful when closing the power sunroof.
- Never allow anyone to be within the sunroof range of operation, especially if it is closing without pinch protection.

- The pinch protection does not prevent fingers or other parts of the body from becoming injured by being pressed against the roof frame.

 Pinch protection also occurs when convenience closing the windows and sunroof with the vehicle key.

Troubleshooting

If the sunroof is not closing

- The sunroof only works when the ignition is on. The sunroof can still be opened or closed for a brief period after the ignition has been switched off, as long as the driver's or front passenger's door has not been opened.
- If it is not possible to close the sunroof using the power controls, the sunroof must be closed manually. Some vehicle components must be removed in order to close the sunroof manually. Contact an authorized Volkswagen dealer or authorized Volkswagen Service Facility. Volkswagen recommends contacting an authorized Volkswagen dealer or authorized Volkswagen Service Facility.

Controls are responding differently than expected

Moisture, dirt and grease may limit the functioning of the controls.

1. Always keep the control panels clean and dry.

Steering wheel

Adjusting the steering wheel position

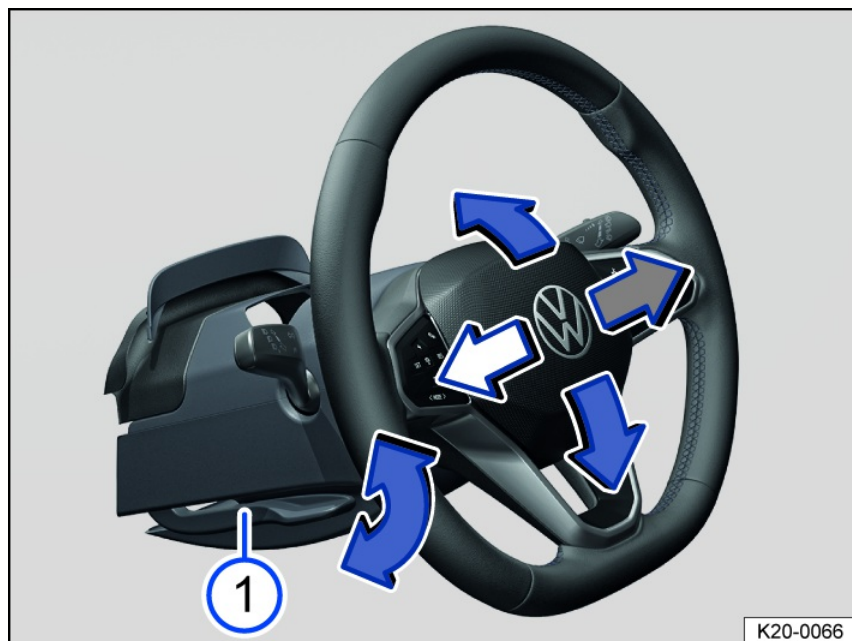

K20-0066

Fig. 66 Under the steering wheel in the steering column trim panel: lever to adjust the steering wheel position manually (general example).



Fig. 67 On the steering wheel: nine o'clock and three o'clock position.

Only adjust the steering wheel before driving or while the vehicle is stationary ⇒ ⚠.

1. Tilt the lever [fig. 66](#) downward.
2. Adjust the steering wheel so that it can be firmly held at the outer edge with both hands at the nine o'clock and three o'clock position [fig. 67](#).

3. Press the lever all the way up until it locks flush with the steering column trim panel ⇒ .

 **WARNING**

Incorrect use of the steering wheel adjuster and an incorrect steering wheel adjustment could cause serious or fatal injuries.

- Always push the lever *fig. 66*  upward into its locked position after adjusting so that you do not change the steering wheel position unintentionally while driving.
- Never adjust the steering wheel while driving. If you find the steering wheel must be adjusted while driving, stop the vehicle safely and adjust the steering wheel correctly.
- The steering wheel must always face toward the chest and never toward the face. Otherwise, the protective function of the driver's front airbag may be limited in the event of an accident.
- To reduce the risk of injuries if the driver's front airbag deploys, always hold the outer edge of the steering wheel firmly with both hands in the nine o'clock and three o'clock position *fig. 67*.
- Never hold the steering wheel in the twelve o'clock position or in any other way, such as holding the center of the steering wheel. Otherwise, the arms, hands, and head could be seriously injured if the driver's front airbag deploys.

Seats and head restraints

Front seats

Introduction

The following information describes the various options for adjusting the front seats. Always make sure the seats are adjusted to the correct position →  [Introduction](#).

WARNING

Driving in an incorrect seating position due to seats being adjusted incorrectly may cause serious injuries.

- Adjust the front seats according to the correct seating position each time before driving and make sure all passengers have their safety belts fastened correctly.
- Move the front passenger seat all the way back.

WARNING

Adjusting the seats incorrectly can cause accidents and serious injuries.

- Only adjust the seats when the vehicle is stationary. Otherwise, the position of the seats could change unexpectedly while driving and you could lose control of the vehicle. You could also put yourself in an incorrect seating position.
- Only adjust the height, angle, and forward/back position of the front seats when there is no one within the seat's range of movement.
- Do not restrict the movement of the seats by placing objects within their range of movement.
- The adjusting and locking areas of the seats must not be dirty.

WARNING

Using seat covers or protective covers incorrectly can result in unintentionally operating the seat adjusters, and the front seats could move unexpectedly while driving. This could cause you to lose control of the vehicle. This can cause accidents and injuries. The electrical components in the front seats could also be damaged.

- Never install or secure seat covers and protective covers on the electrical controls.
- Only use seat covers or protective covers that are specifically approved for use in your vehicle.

WARNING

Lighters in the vehicle can become damaged or ignite unintentionally. This can cause severe burns and vehicle damage.



- Before adjusting any seat, always make sure that there are no cigarette lighters near the moving parts of the seat.

NOTICE

Objects with sharp edges can damage the seats.

- Never touch the seats with sharp-edged objects. Sharp-edged objects, such as zippers, rivets on clothing, or belts, can cause surface damage. Open hook and loop fasteners can also cause damage.

Manually adjusting front seats

 Please read the introductory information and heed the Warnings and Notice →  and  [Introduction](#).

The information that follows describes all possible controls. Depending on the seat version, the number of controls may vary.

The controls on the front passenger seat are a mirror image of those for the driver seat.

A seat may have both manual and power controls.



Fig. 68 On the driver seat: Controls (depending on the vehicle equipment).

- ① To adjust the backrest, turn the handwheel with nothing resting on the backrest.
- ② If necessary, move the lever upward or downward multiple times to adjust the height of the seat.
- ③ Pull or push the lever several times if necessary to adjust the seat cushion angle.
- ④ Lift the grip to move the seat cushion forward or backward.
- ⑤ Pull the lever to slide the front seat forward or backward. The front seat must lock into place after the lever is released.

Adjusting power front seats

📖 Please read the introductory information and heed the Warnings and Notice ⇒ ⚠ and ⓘ Introduction.

The controls on the front passenger seat are a mirror image of those for the driver seat.

A seat may have both manual and power controls.

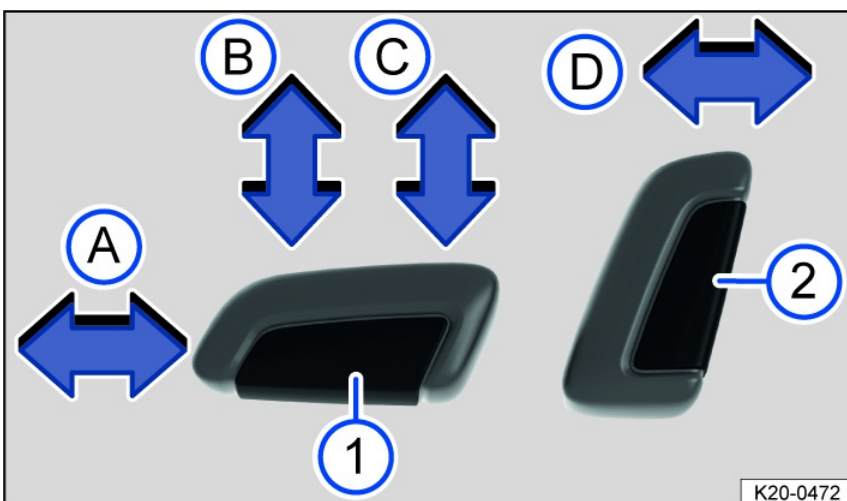

Fig. 69 Switch on the driver seat: Adjusting the front seat forward/back, the height and angle of the seat surface, and the front seat backrest.

Press the switch in the direction of the arrow:

- Ⓐ Slide the seat forward or backward.
- Ⓑ Adjust the angle of the seat surface.
- Ⓒ Adjust the height of the seat.
- Ⓓ Adjust the angle of the backrest.

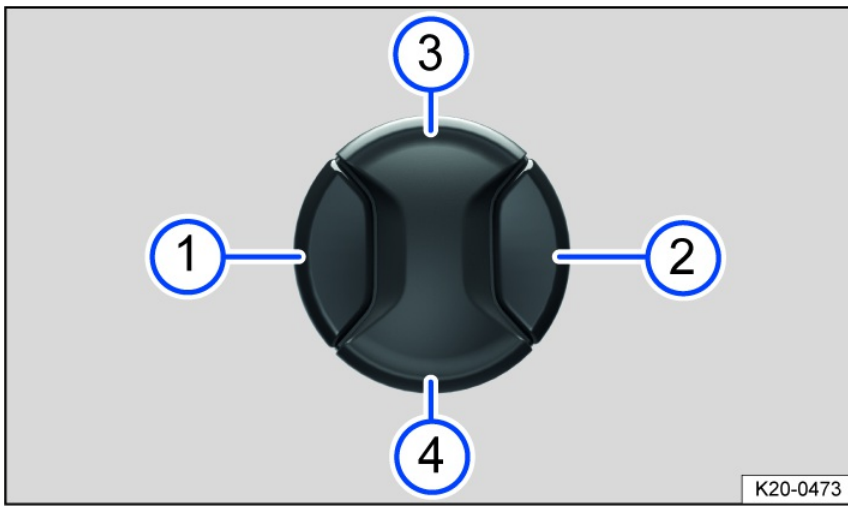

Fig. 70 Switch on the driver seat: Adjusting the lumbar support.

Press the switch in the direction you would like the lumbar support to move.

- ① Move the curvature of the lumbar support forward.
- ② Move the curvature of the lumbar support backward.
- ③ Raise the curvature of the lumbar support.
- ④ Move the curvature of the lumbar support down.

⚠ WARNING

Careless or unintended use of the power front seats can cause serious injuries.

- The power front seats can also be adjusted when the ignition is switched off. Never leave children or people requiring assistance in the vehicle.
- In case of an emergency, interrupt the power adjustment by pressing another switch.

ⓘ NOTICE

To reduce the risk of damage to the electrical components in the front seats, never kneel on the front seats or seat cushions. Do not exert pressure on the backrest with sharp or pointed objects.

ⓘ If the 12 V vehicle battery charge level is too low, the seat may not be able to be adjusted with the power controls.

ⓘ A seat adjustment may be canceled while the engine is starting.

Rear seats

📖 Introduction

The following information describes the various options for adjusting the rear seats. Always make sure the seats are adjusted to the correct position ⇒ *Correct seating position*.

⚠ WARNING

Adjust the rear seats correctly before each journey and make sure all passengers have their own safety belts fastened correctly.

- Only adjust the rear seats when the vehicle is stationary. Otherwise, the rear seats could move unexpectedly while the vehicle is in motion. You could also put yourself in an incorrect seating position.
- For passengers in the rear seats, the risk of serious injuries increases if they do not sit upright, because the safety belts will not be positioned correctly.
- Only adjust the rear seat when there is no one within the seat's range of movement.

⚠ WARNING

Lighters in the vehicle can become damaged or ignite unintentionally. This can cause severe burns and vehicle damage.

- Before adjusting any seat, always make sure that there are no cigarette lighters near the moving parts of the seat.

⚠ WARNING

To reduce the risk of injuries while driving, the rear center armrest must always be folded up.

- If the center armrest is folded down, the center rear bench seat must never be used by either adults or children. Doing so would create an incorrect seating position that could result in serious injuries.
- Never allow an adult or child to ride on the center armrest.

NOTICE

- Objects in the luggage compartment can cause damage when adjusting the rear seat forward or backward.
- If the rear seat is positioned forward, objects can become caught between the seat and the luggage compartment floor. Remove any objects from this area before sliding the rear seat back.

NOTICE

Objects with sharp edges can damage the seats.

- Never touch the seats with sharp-edged objects. Sharp-edged objects, such as zippers, rivets on clothing, or belts, can cause surface damage. Open hook and loop fasteners can also cause damage.

Folding the rear bench seat backrest forward or backward

📖 Please read the introductory information and heed the Warnings and Notice ⇒ ⚠ and ⚠ Introduction.

The seat backrest is divided. Each part of the rear seat backrest can be folded forward individually to enlarge the luggage compartment.

Folding the rear seat backrest forward and down with the release button



Fig. 71 In the rear seat backrest: release button.

1. Move the head restraints all the way down.
2. Pull the release button *fig. 71* forward while folding the rear seat backrest forward and down.

The respective backrest part of the rear seat backrest is released when the red marking *fig. 71* can be seen.

Folding the rear seat backrest up and back

1. Fold the rear seat backrest to the back and push firmly into the catch until it securely engages ⇒ ⚠.

The red marking *fig. 71* must no longer be visible.

WARNING

Folding and unfolding the rear seat backrest in an uncontrolled or careless manner may cause severe injury.

- Always take care that no people or animals are in the way of the rear seat backrest when folding it forward and down.
- Never fold the rear seat backrest forward or back while driving.
- Make sure the safety belt is not pinched or damaged when folding the rear seat backrest back.
- Keep hands, fingers, feet and other body parts away from the rear seat backrest when folding forward or back.

- Each rear seat backrest must always be securely engaged to ensure that the safety belts in the rear seats can provide the maximum protection. Take extra care especially with the middle seat in the rear bench seat. If a seat on the rear bench is used without the rear seat backrest being engaged, the vehicle occupant will move forward with the rear seat backrest in the event of sudden braking and driving maneuvers or a collision.
- A red marking *fig. 71* indicates that the rear seat backrest is not engaged. Always check that the red marker is not visible when the rear seat backrest is in the upright position.
- Never allow people to sit in a rear seat if that rear seat backrest is folded forward or is not engaged.

NOTICE

Folding and unfolding the rear seat backrest in an uncontrolled or careless manner may cause damage to the vehicle or other objects.

- Before folding the rear seat backrest forward, always adjust the front seats so that the head restraint or padding on the rear seat backrest does not press against the front seats.
- Before folding the rear seat backrest forward, always take care that there are no objects in its path.

Head restraints

Introduction

The information that follows describes how the head restraints can be adjusted and removed. Always make sure the seats are adjusted to the correct position ⇒ *Correct seating position*.

All seats are equipped with head restraints. The head restraints are specially approved for the relevant seat and should not be installed in another seat in the vehicle.

The center rear head restraint (depending on the vehicle equipment) is only intended for the center seat on the rear bench seat. Therefore do not install this head restraint in any other position.

There are notches in the head restraint supports so that they can be locked in different positions. Only head restraints which are correctly mounted can lock into the notches within the adjustable range. To prevent the head restraints from being removed unintentionally after mounting, there are stops at the top and bottom of the adjustable range.

Correct head restraint adjustment

Adjust the head restraint so that the upper edge of the head restraint is in line with the upper portion of the head as much as possible, but not lower than eye level. Position the back of the head as close as possible to the head restraint.

Head restraint adjustment for shorter persons

Slide the head restraint all the way down, even if the head is then below the upper edge of the head restraint. When the head restraint is in the lowest position, there may be a small gap between the head restraint and the backrest.

Head restraint adjustment for taller persons

Move the head restraint up all the way.

WARNING

Driving with head restraint that have been removed or adjusted incorrectly increases the risk of serious or fatal injuries in the event of an accident or sudden driving and braking maneuvers.

- If a person is sitting in a seat, always drive with the head restraint correctly installed and adjusted on that seat.
- If a person is sitting in a seat, adjust the head restraint according to their height.
- Never adjust the head restraint while driving.

NOTICE

When removing and installing the head restraint, make sure the head restraint does not hit the headliner, the front seat backrest, or other vehicle components. Otherwise, damage could result.

Adjusting the head restraints

 Please read the introductory information and heed the Warnings and Notice ⇒  and  Introduction.

Adjusting the height of the head restraints

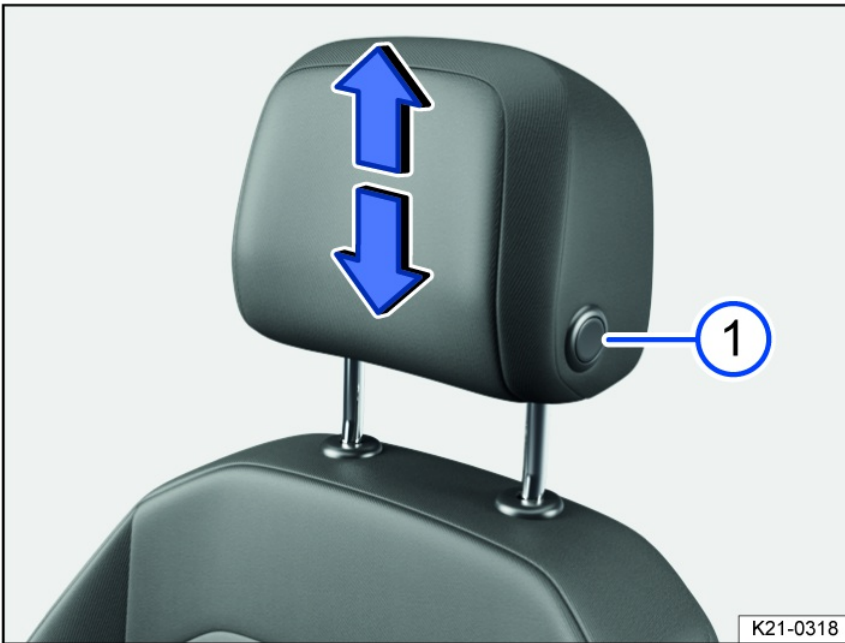

Fig. 72 General example: Adjusting the front head restraint forwards and backwards.

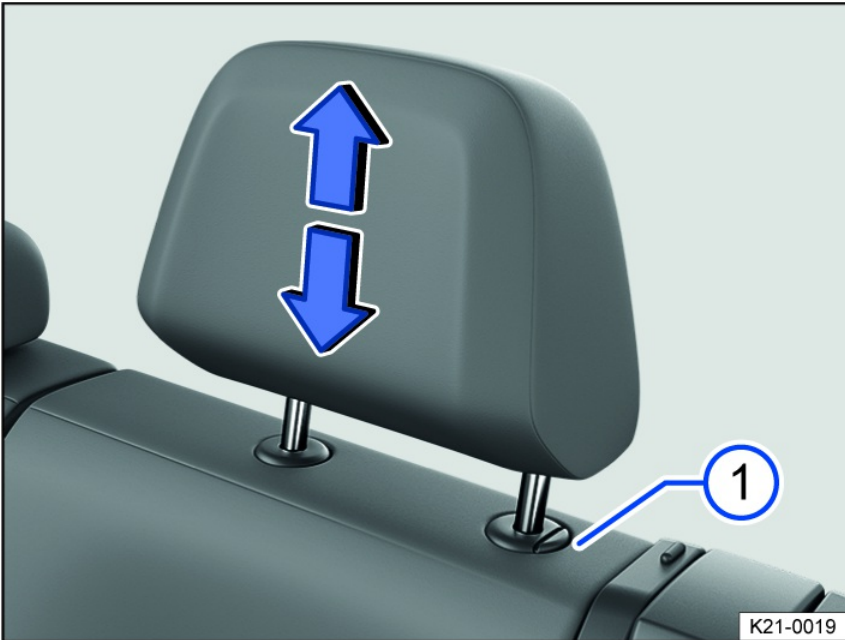

Fig. 73 General example: adjusting the rear head restraint.

1. Slide the head restraint up or down in the direction of the arrow; you may need to press the [fig. 72](#) or [fig. 73](#) button first to release the head restraint.

The head restraint must lock securely into place.

Adjusting the front head restraint forwards and backwards

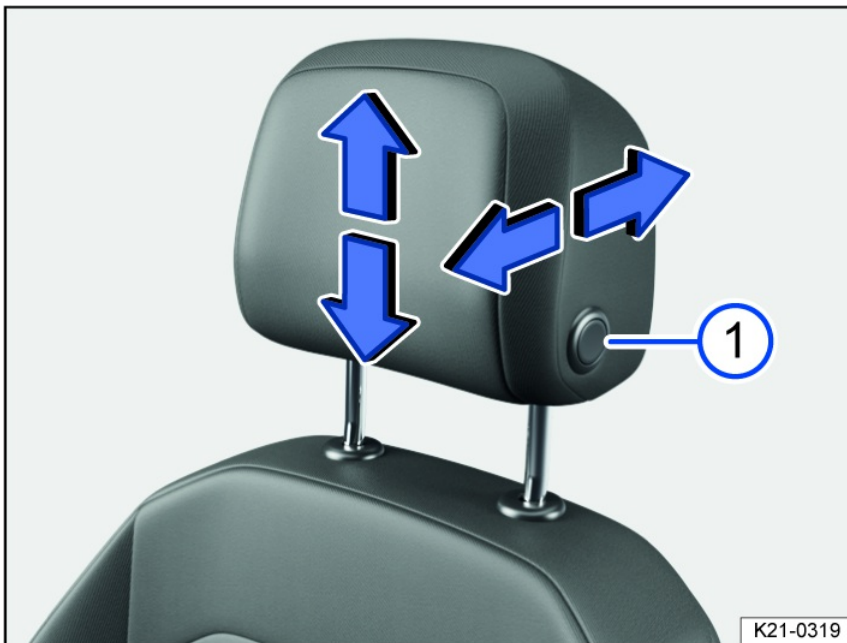

Fig. 74 General example: adjusting the front head restraint with forward/backward adjustment.

1. Push the head restraint forward in the direction of the arrow or, keeping the button *fig. 74* pressed, push the head restraint backward.

The head restraint must lock securely into place.

Removing and installing the head restraints

📖 Please read the introductory information and heed the Warnings and Notice ⇒ ⚠️ and ⓘ *Introduction.*

Removing the front head restraints

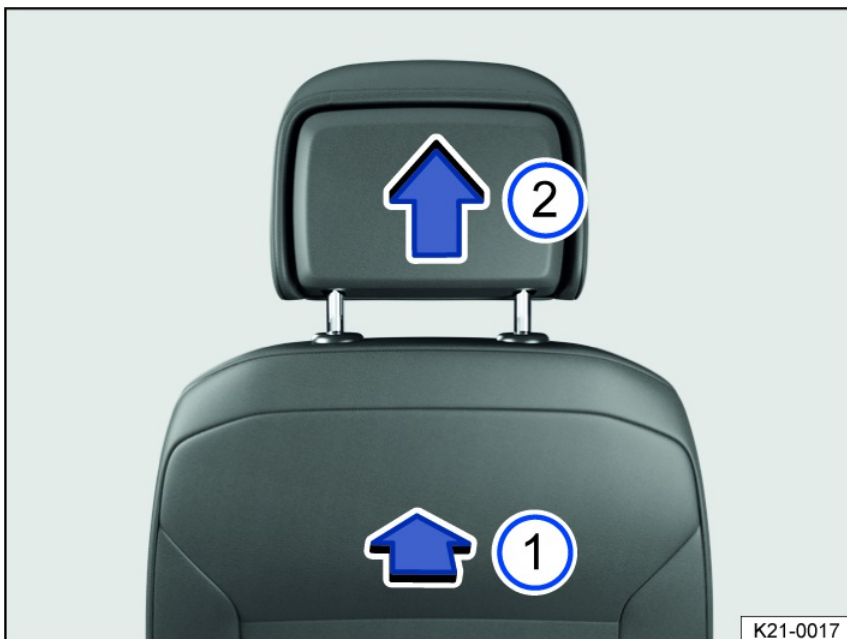

Fig. 75 General example: removing the front head restraint.

1. Lower the head restraint if necessary.
2. To release, find the notch on the rear side in the marked area *fig. 75*, push inwards in the direction of the arrow and hold.
3. Pull out the head restraint in the direction of the arrow *fig. 75*.

Installing the front head restraints

1. Position the head restraint correctly above the head restraint guides and insert into the guides on the seat backrest.
2. Slide the head restraint downward until it engages into the guide rods.
3. Adjust the head restraint to the correct position.

Removing the rear head restraint

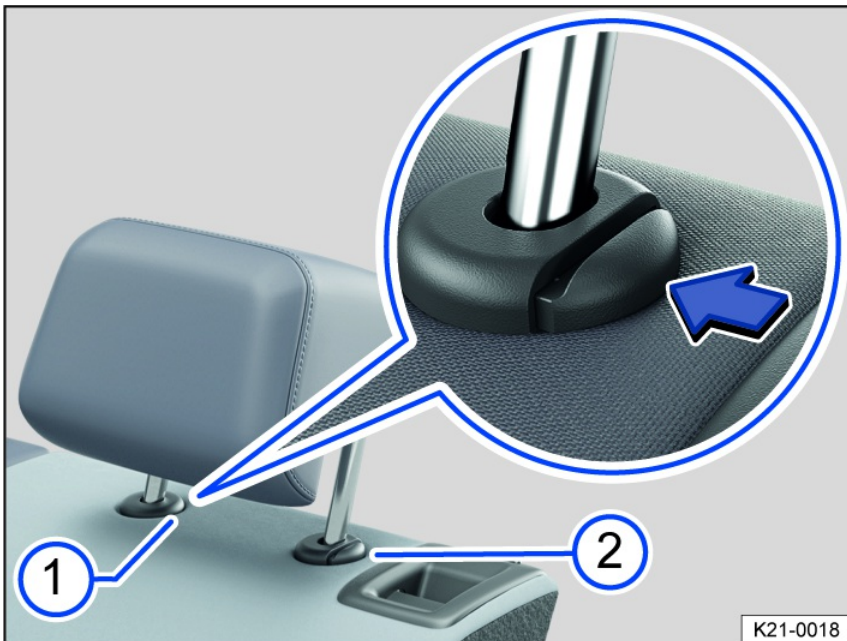

Fig. 76 General example: removing the rear head restraint.

1. Release the backrest of the rear bench seat and fold forwards.
2. Slide the head restraint all the way upward ⇒ *Adjusting the head restraints*.
3. Press the button *fig. 76* on the head restraint guide.
4. At the same time, press button ② while a second person pulls the head restraint all the way out.
5. Fold the rear bench seat backrest toward the rear and lock it securely into place.

Installing the rear head restraint

1. Release the backrest of the rear bench seat and fold forwards.
2. Position the head restraint correctly above the head restraint guides and insert into the guides on the seat backrest.
3. Push the head restraint downward while pressing the *fig. 76* button.
4. Fold the rear bench seat backrest toward the rear and lock it securely into place.
5. Adjust the head restraint to the correct position.

Seat functions

Center armrest

Front center armrest



Fig. 77 Front center armrest (general example).

- To lift: Pull the center armrest up to the detents in the direction of the arrow *fig. 77*.
- To lower: Pull the center armrest up fully. Then press the center armrest down.
- Forward and backward adjustment: Slide the center armrest in the direction of the arrow *fig. 77* all the way forward or all the way backward.

If the front center armrest is opened all the way or not completely closed, it can limit the driver's ability to move his or her arms, which can cause accidents and serious injuries.

- Always keep the storage compartments closed while driving.
- Never allow an adult or child to ride on the center armrest. This incorrect seating position can cause serious injuries.

Rear center armrest



Fig. 78 Folding center armrest in the rear.

There may be a folding armrest in the backrest of the rear center seat.

- To fold forward: pull the center armrest in the direction of the arrow *fig. 78*.
- To fold back: fold the center armrest upward in the opposite direction of the arrow *fig. 78* and press it all the way toward the seat backrest.

Passengers must not sit in the center rear seat when the center armrest is folded down.

⚠ WARNING

To reduce the risk of injuries while driving, the rear center armrest must always be folded up.

- If the center armrest is folded down, the center rear bench seat must never be used by either adults or children. Doing so would create an incorrect seating position that could result in serious injuries.

Memory function

Memory buttons

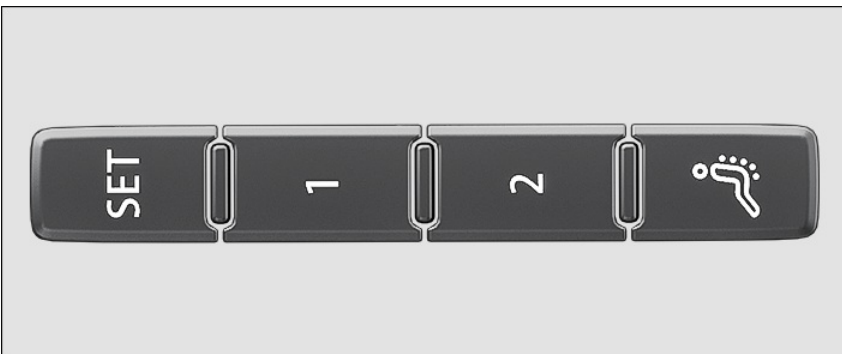

Fig. 79 On the outer side of the driver's seat: memory buttons.

Driver seat and outside mirror settings can be saved and called up using the memory buttons.

Storing the driver's seat and outside mirror settings for driving forward

1. Set the electronic parking brake.
2. Shift the transmission to neutral.
3. Switch the ignition on.

4. Adjust the driver's seat and outside mirror.
5. Press the **SET** *fig. 79* button for longer than ten seconds.
6. Press the desired memory button within approximately ten seconds.

A chime will confirm that the settings were saved.

Storing the front passenger's outside mirror settings for driving in reverse

1. Set the electronic parking brake.
2. Shift the transmission to neutral.
3. Switch the ignition on.
4. Press the desired memory button *fig. 79*.
5. Select the reverse gear.
6. Adjust the front passenger's outside mirror so that the edge of the curb can be seen clearly, for example.

The selected mirror position will be stored automatically and assigned to the vehicle key that was used to unlock the vehicle.

Recalling driver's seat and outside mirror settings

1. When the vehicle is stationary, the ignition is switched off, and a door is open, press the respective memory button briefly.

After approximately ten minutes, the stored positions can no longer be adjusted automatically. The adjustment process will be canceled if one of the memory buttons is pressed again.

Or: When the ignition is switched on or the door is closed, press and hold the respective memory button until the saved positions are reached.

The front passenger's outside mirror automatically leaves the position stored for driving in reverse once you begin driving forward at speeds of at least approx. 15 km/h (approx. 10 mph) or when you turn the knob for the outside mirrors from the **R** position to another position.

! If you open the driver door more than approximately ten minutes after the vehicle is unlocked, the driver seat and the outside mirrors will not be adjusted automatically.

Front seat convenience entry function

When you open the driver door, the driver seat automatically moves to a position that enables you to enter and exit the vehicle with ease.

The driver seat automatically returns to its original position once you have closed the driver door and switched on the ignition.

The front seat convenience entry function can be enabled and disabled in the Infotainment system.

! WARNING

Improper use of seat functions can cause injuries.

- Before beginning a journey always adjust to the correct seat position and maintain this throughout the journey. This also applies to all passengers.
- Set the memory function only with the vehicle stationary.
- Always keep your hands, fingers, feet and other parts of your body clear of the area in which the seats operate and move during adjustment.

¹⁾ Only if personalization has been activated.

Massage feature

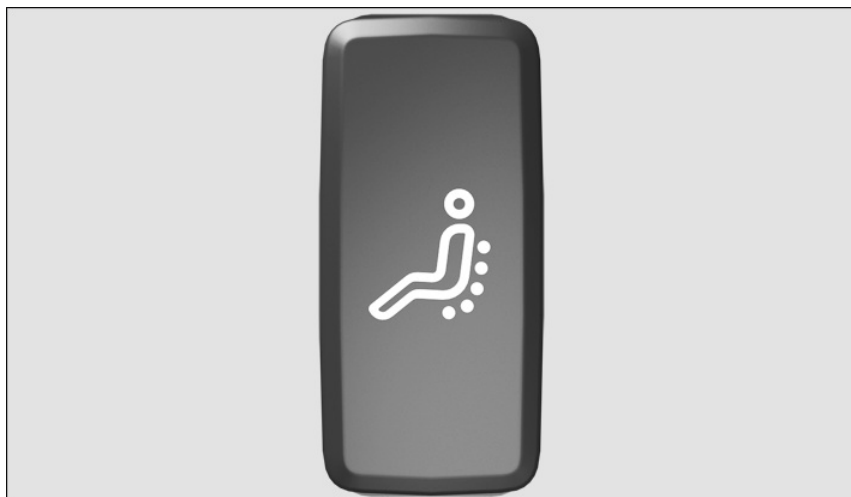

Fig. 80 In the lower part of the driver seat: Massage function button.

For the massage function, the lumbar support moves and massages the lumbar area of your back.

The lumbar support cushioning can be individually adjusted during operation by pressing repeatedly on the corresponding switch ⇒ *Adjusting power front seats.*

Switching the massage function on or off

1. To switch on, push the  button in the seat control panel. Press the  button again to switch off.

After around ten minutes, the massage function switches off automatically.

WARNING

Improper use of seat functions can cause injuries.

- Before beginning a journey always adjust to the correct seat position and maintain this throughout the journey. This also applies to all passengers.
- Only switch the massage function on and off when the vehicle is stationary.
- Always keep your hands, fingers, feet and other parts of your body clear of the area in which the seats operate and move during adjustment.

Lights

Headlights

Switching the turn signals on and off

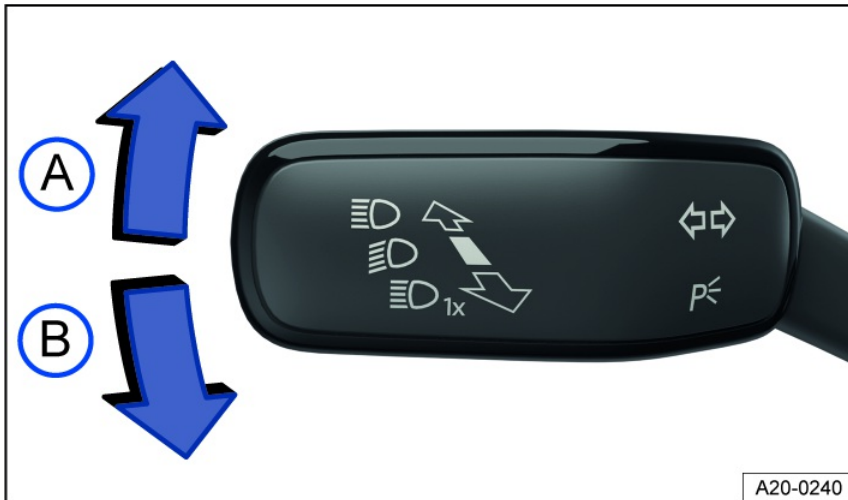

Fig. 81 On the left side of the steering column: turn signal and high beam lever.

- A Right turn signal ➔.
- B Left turn signal ➜.

Switching the turn signals on and off

1. Switch the ignition on.
2. Move the turn signal and high beam lever from the center position to the preferred position [fig. 81](#).
3. To cancel the turn signal, move the turn signal and headlamp lever back to its basic position.

If no chime sounds when the turn signal is on, contact suitably qualified professionals and have the vehicle checked. Volkswagen recommends contacting an authorized Volkswagen dealer or authorized Volkswagen Service Facility.

3-blink turn signal

To use the 3-blink turn signal, move the turn signal and high beam lever upward or downward to the pressure point and then release the lever. The turn signal will blink three times.

To stop the 3-blink turn signal before it ends, move the turn signal and high beam lever immediately to the pressure point in the opposite direction and release.

The 3-blink turn signal can be activated and deactivated in the vehicle settings in the Infotainment system ➔ [Vehicle settings menu](#).

⚠ WARNING

Using the turn signals incorrectly, not using the turn signals, or forgetting to turn the turn signal off can mislead other road users. This can cause accidents and serious injuries.

- Always activate the turn signals correctly when changing lanes, passing, or turning.
- Switch the turn signal off again every time you finish changing lanes, passing, or turning.

 The emergency flashers also work when the ignition is switched off ➔ [In case of an emergency](#).

Switching the lights on and off



Fig. 82 Next to the steering wheel: light switch (one version).

Switching the lights on

1. Switch the ignition on.
2. Turn the light switch to the desired position [fig. 82](#):

0 The side lights or parking lights and daytime running lights are switched on.

AUTO Automatic headlight control: the headlights will switch on or off depending on the brightness and weather conditions ⇒ , ⇒ *Automatic headlight control*.

 The side lights or parking lights and daytime running lights are switched on. The green symbol in the light switch turns on.

 The low beam headlights are switched on.

Switching the lights off

1. Switch the ignition off.
2. Turn the light switch to the desired position:

0 The lights are switched off.

AUTO The orientation lighting can be switched on ⇒ *“Exit lighting” and “Entry lighting” function (orientation lighting)* .

 The parking light is switched on ⇒ *Parking lights*. The green symbol in the light switch turns on.

 The low beam headlights are switched off.
Vehicles with starter button: As long as the driver door is closed, the parking light continues to light up.

Daytime running lights

The optional daytime running lights can increase the visibility of your vehicle in traffic during the daytime.

The daytime running light comes on automatically every time the ignition is switched on if the light switch is in the **0**,  or **AUTO** position (if brightness detected)

The daytime running lights cannot be switched on or off manually.

Daytime running lights parking function

Depending on the equipment, the vehicle may have a daytime running lights parking function to turn off the daytime running lights temporarily when the ignition is switched on.

Switch off the daytime running lights:

1. Switch the ignition on.
2. Turn the light switch to the **0** position.
3. Set the electronic parking brake.

Switch on the daytime running lights:

1. Switch off the electronic parking brake.

WARNING

Accidents and serious injuries may occur if the road is not well lit and the vehicle cannot be seen by others on the road, or is very difficult to see.

- The light assistance systems are only aids. The driver is always responsible for turning on the correct vehicle lighting.
- Always turn on the low beam headlight in the dark, when it is raining, and when visibility is poor.
- Regularly check that the lighting system and turn signals are functioning correctly.

⚠ WARNING

The parking lights or daytime running lights are not bright enough to illuminate the road sufficiently and to be seen by other road users.

- Always turn on the low beam headlight in the dark, when it is raining, and when visibility is poor.
- The taillights do not switch on with the daytime running lights. A vehicle without its taillights turned on may not be seen by other road users in the dark, in the fog, and when visibility is poor.

⚠ WARNING

Automatic headlight control **AUTO** only turns the low beam headlights on and off when there are changes in brightness.

- Turn on the low beam headlights manually in certain weather conditions, such as in fog.

 When reverse gear is engaged, the cornering lights on both sides of the vehicle will turn on automatically to better illuminate the surroundings while maneuvering.

Switching the high beam headlights on and off

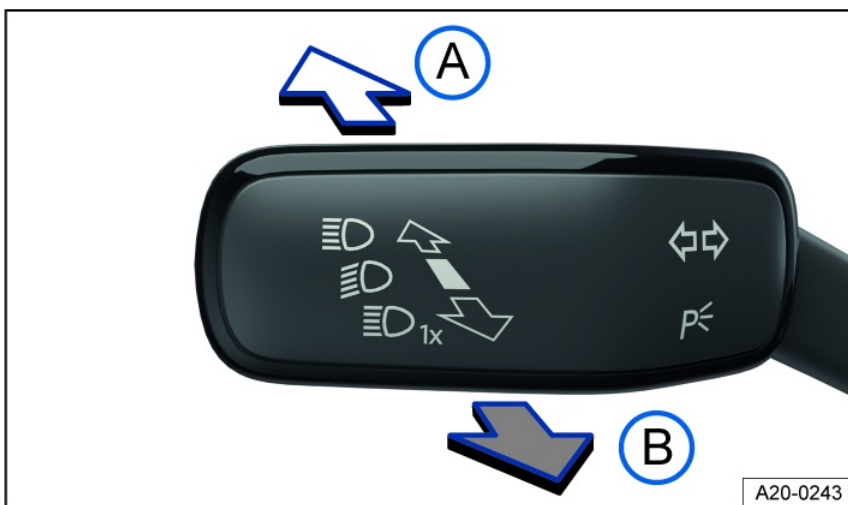





Fig. 83 On the left side of the steering column: turn signal and high beam lever.

- A**  Turn on the high beam headlight.
- B**  Activate the headlight flashers or turn off the high beam headlights.

If the high beam headlights or headlight flashers are turned on, the blue  indicator light will come on in the Volkswagen Digital Cockpit ⇒ .

Turning on the high beam headlight

1. Switch the ignition on.
2. Switch on the low beam headlight.
3. Press the turn signal and high beam lever forward out of the center position *fig. 83*.

Turning off the high beam headlight

1. Pull the turn signal and high beam lever backward out of the center position *fig. 83*.

Turning the headlight flasher on and off

1. Pull the turn signal and high beam lever backward out of the center position and hold it *fig. 83*.
Release the turn signal and high beam lever to turn the headlight flasher off.

Light Assist

Depending on the equipment, high beam control (Light Assist) may be available ⇒ *Light Assist*.

⚠ WARNING

Using the high beam headlights incorrectly can cause accidents and serious injuries, because the high beams can distract and create glare for other drivers.

- Use the high beam headlights only if other road users cannot be distracted or blinded.



Light Assist

Light Assist switches off automatically if the system detects oncoming vehicles or vehicles driving ahead. Light Assist generally detects well-lit areas such as towns and deactivates the high beam headlights when driving through these areas.

The high beam headlights switch on and off automatically within the limits of the system, depending on the environmental and traffic conditions and the vehicle speed ⇒ .



Switching on Light Assist

1. Switch on the ignition and the automatic headlights **AUTO**.
2. Tap the turn signal and high beam lever forward out of the basic position.

When Light Assist is switched on, the  indicator light in the instrument cluster display will turn on. When high beam control (Light Assist) is active, the blue indicator light  for the high beam headlight in the instrument cluster lights up.

Setting the main-beam control sensitivity

Depending on the country, the main-beam control sensitivity can be set in two stages:

- *Increasing the sensitivity:* press the turn signal and high beam lever forwards from its original position and hold it in this position for around 15 seconds.
The  indicator light on the instrument cluster will blink three times to confirm that this has been applied.
 - *Setting the sensitivity back to its standard setting:* press the turn signal and high beam lever forwards from its original position and hold it in this position for around 15 seconds.
The  indicator light on the instrument cluster will blink three times in quick succession to confirm that this has been applied.
- Or:** Switch the ignition off and on.

Switching off Light Assist

1. Switch off **AUTO** automatic headlights.

Or: If high beam control (Light Assist) is switched on and active, pull the turn signal and high beam lever backward.

Or: If high beam control (Light Assist) is switched on and not active, tip the turn signal and high beam lever forward.

The manual high beam headlights are now switched on. Pull the turn signal and high beam lever backwards to switch the high beam headlights off manually if necessary.

Or: Switch off the ignition.

System limitations

The high beams must be switched off manually in the following situations, because Light Assist may not switch them off at the right time or at all:

- In poorly lit towns which cannot be recognized as a town by the system.
- On poorly lit roads with strongly reflective signs.
- If there are others on the road who have inadequate lighting, such as pedestrians or cyclists.
- On tight curves where the view of traffic is partially obstructed, on steep rises, or in dips.
- When there are oncoming vehicles on roads with a center barrier and the drivers in the oncoming vehicle can clearly see above the barrier, for example truck drivers.
- In fog, snow, and heavy rain.
- When there are dust and sand in the air.
- If the windshield is damaged in the camera's field of vision.
- If the camera visual field is fogged over, dirty, or covered by a sticker, snow, or ice.
- If the camera switches off automatically due to a high ambient temperature or exposure to direct sunlight for a prolonged period. High beam control (Light Assist) will be available once the camera is available again.
- If the camera is faulty and the power supply is interrupted.

WARNING

The increased convenience thanks to high beam control (Light Assist) cannot replace the driver's attention. Switching on the high beam headlights incorrectly can cause accidents and serious injuries, because the high beams can distract and blind other drivers.

- Always control the headlights yourself and adapt them to the lighting, visual, and traffic conditions.
- Light Assist may not detect all traffic situations correctly and the function may be restricted in certain situations.
- If the camera lens is dirty, covered, or damaged, the Light Assist function may be limited. This is also the case if the vehicle lighting system is changed, such as by adding auxiliary headlights.

NOTICE

To avoid impairing the function of the system, note the following points:

- Regularly clean the camera view area and keep it free of snow and ice.
- Do not cover the camera view area.
- Regularly check the windshield for damage in the camera lens area.

Dynamic cornering light

The dynamic cornering lights provide optimum illumination of the roadway.



The dynamic cornering light only works when the automatic headlights **AUTO** are switched on and at speeds of more than approximately 6 mph (approximately 10 km/h).

Switching the poor weather lights on and off

Poor weather lights help you to illuminate the carriageway more effectively when visibility is poor.

The poor weather light can be switched on when the ignition is switched on and the automatic headlights **AUTO** or dipped beams  are switched on.

Switching on the Poor Weather Lights

1. Switch the ignition on.
2. Automatic headlights **AUTO** or dipped beams  switched on.
3. Press the  button ⇒ *Switching the lights on and off*.

The green indicator light in the button turns on.

Switching off the Poor Weather Lights

1. Press the  button again.

 **If the poor weather light is switched on when the automatic headlights are switched on **AUTO**, the dipped beams are also switched on, regardless of the ambient light level.**

Troubleshooting

Turn signal indicator light

The green indicator light blinks.

If a turn signal light on the vehicle is not working, the indicator light will blink twice as fast.

1. Check the lights and replace any bulbs as necessary ⇒  *Exterior lighting using LED technology*.
2. If the malfunction persists, contact a suitably qualified professional. Volkswagen recommends contacting an authorized Volkswagen dealer or authorized Volkswagen Service Facility.

Trailer turn signal indicator light

The green indicator light blinks.

If a trailer turn signal or the entire trailer light system is out, the indicator light will turn off.

1. Check the lights and replace any bulbs as necessary ⇒  *Exterior lighting using LED technology*.
2. If the malfunction persists, contact a suitably qualified professional. Volkswagen recommends contacting an authorized Volkswagen dealer or authorized Volkswagen Service Facility.

Exterior lighting malfunction

The yellow indicator light turns on.

The headlights have completely or partially failed.

1. Check the lights and replace any bulbs as necessary ⇒  *Exterior lighting using LED technology*.
2. If the malfunction persists, contact a suitably qualified professional. Volkswagen recommends contacting an authorized Volkswagen dealer or authorized Volkswagen Service Facility.

Rain/light sensor malfunction

The yellow indicator light turns on.

In the **AUTO** light switch position, the vehicle lighting will not turn on or off automatically.

1. Switch the ignition off and on.
2. If the malfunction persists, contact a suitably qualified professional. Volkswagen recommends contacting an authorized Volkswagen dealer or authorized Volkswagen Service Facility.

Dynamic cornering light

When travel mode is activated, the dynamic cornering light does not work.

The swivel behavior of the bulbs can be influenced by the selected driving mode.

If the dynamic cornering light malfunctions, this is indicated on the instrument cluster display. Contact a suitably qualified professional. Volkswagen recommends contacting an authorized Volkswagen dealer or authorized Volkswagen Service Facility.

Parking lights

Parking lights

Parking lights

If the  parking light function is switched on, both headlights will come on, along with the parking lights, sections of the taillights, the license plate light and various buttons in the vehicle interior.

Automatic parking light deactivation

The vehicle detects that the 12 V vehicle battery is low and switches off the parking light early enough to ensure that the engine can still be started, but not until at least two hours have passed.

If the battery capacity is not sufficient for the parking light to run for two hours, the 12 V vehicle battery may drain to such an extent that the engine can no longer be started.

WARNING

If the vehicle is stopped without enough lighting so that the vehicle cannot be seen or is difficult for others on the road to see, this can cause accidents and serious injuries.

- Always stop the vehicle safely and with enough lighting. Follow the country-specific legal regulations.

“Exit lighting” and “Entry lighting” function (orientation lighting)

When you are entering and exiting the vehicle in the dark, the “Exit lighting” and “Entry lighting” function illuminates the immediate area around the vehicle.

Depending on the equipment, the vehicle can have an automatic or manual “Coming home” function:

- **Automatic “Coming home” function:** the “Coming home” and “Leaving home” function automatically control the rain/light sensor.
- **Manual “Coming home” function:** the “Coming home” function is switched on manually.

The “Leaving home” function automatically controls the rain/light sensor.

The lighting time can be adjusted in the vehicle settings in the Infotainment system and the function can be activated or deactivated ⇒ [Vehicle settings menu](#).

Switching on the automatic “Coming home” function

1. Switch the ignition off.

The “Coming home” lighting switches on automatically when the light switch is in the **AUTO** position and the rain/light sensor detects darkness.

The lighting time begins when the last vehicle door or trunk lid is closed.

Switching on the manual “Coming home” function

1. Switch the ignition off.
2. Press the headlight flasher.

The “Coming home” lighting switches on automatically when the driver door opens. The switch-off delay begins when the last door or the trunk lid is closed.

Switching the “Exit lighting” function off

1. Turns off automatically after the set lighting time has elapsed.

Or: Automatically if a vehicle door or the trunk lid is still open approximately 30 seconds after switching on.

Or: Switch off the light.

Or: Switch on the ignition.

Switching the “Entry lighting” function on

1. Unlock the vehicle when the automatic headlight control **AUTO** is switched on and the rain/light sensor detects darkness.

Switching the “Entry lighting” function off

1. Turns off automatically after the lighting time has elapsed.

Or: Lock the vehicle.

Or: Switch off the light.

Or: Switch on the ignition.

Light functions

Cornering lights

If the low beam headlights are switched on, a cornering light will also switch on during slow turns or in very tight corners.

 **When reverse gear is engaged, the cornering lights on both sides of the vehicle will turn on automatically to better illuminate the surroundings while maneuvering.**

Automatic headlight control

If automatic headlights **AUTO** are switched on, the vehicle lighting switches on and off automatically along with the instrument illumination under the following conditions:

- The light sensor has detected darkness.
- The windshield wipers are switched on for a long time.

When the lights are turned on, the yellow indicator light **AUTO** turns on ⇒ *Switching the lights on and off*.

Automatic headlight control is merely an aid and cannot always accurately detect all driving situations.

If the vehicle is equipped accordingly, the activation time of the automatic headlights can be adjusted in the vehicle settings in the Infotainment system ⇒ *Vehicle settings menu*.

Headlight range control

Headlight range control is used to adjust the beam of the dipped beam headlight to the load level of the vehicle. This provides the driver with the best possible visibility and oncoming traffic is not dazzled.

Dynamic headlight range control

The headlight range automatically adjusts to the vehicle load when the headlights are switched on ⇒ .

WARNING

If the headlight range control fails or malfunctions, the headlights may blind and distract other road users. This can cause accidents and serious injuries.

- Have the headlight range control inspected immediately by an authorized Volkswagen dealer or authorized Volkswagen Service Facility. Volkswagen recommends contacting an authorized Volkswagen dealer or authorized Volkswagen Service Facility.

Adjusting headlights (travel mode)

When traveling in countries that drive on the opposite side of the road from your home country, the asymmetric low beam headlights can dazzle oncoming traffic. Therefore, when driving in such countries, certain headlight variants must be adjusted, or certain areas of the headlight lens must be masked off. For further information, contact an authorized Volkswagen dealer or authorized Volkswagen Service Facility. Volkswagen recommends contacting an authorized Volkswagen dealer or authorized Volkswagen Service Facility.

 **Travel mode may be used only for a short period of time. Contact an authorized Volkswagen dealer or authorized Volkswagen Service Facility for permanent conversion. Volkswagen recommends contacting an authorized Volkswagen dealer or authorized Volkswagen Service Facility.**

Warning tones when lights are not turned off

If the ignition has been switched off and the driver door is opened, warning tones will sound under the following conditions:

- With the side lights switched on ⇒ .

If the orientation lighting is switched on, the warning tone to indicate that the light is still turned on will not sound when leaving the vehicle ⇒ *“Exit lighting” and “Exit lighting” function (orientation lighting)*.

Interior lighting

Instrument and switch illumination

You can adjust the brightness of the instrument illumination in the vehicle settings in the Infotainment system ⇒ *Vehicle settings menu*.

The selected brightness will automatically adjust to the changing brightness in the vehicle.

If the automatic headlights **AUTO** are switched on, a sensor switches the dipped beams and the instrument and switch lighting on and off automatically based on outside brightness.





 **The instrument illumination for the needles and dials turns on when the ignition is on and the lights are off. The lighting for the gauges reduces automatically and eventually turns off as brightness outside increases. This function should remind the driver to turn off low beam headlights at the right time, such as when driving through tunnels.**

Interior/reading lights, ambient lighting

Switching on or off interior and reading lights

The scope and the depiction of the controls in the headliner vary depending on the vehicle equipment.

Press the corresponding button:

 Switch the front interior lights on or off.  Switch the rear interior lights on or off.  The interior lights will switch on automatically when unlocking or leaving the vehicle.  Switch the reading lights on or off.  Switch the ambient surface lighting on or off. Depending on the vehicle equipment: Switch between the highest brightness level and the set brightness level of ambient surface lighting in the roof console → page , *Ambient lighting*.

Glove compartment and luggage compartment lights

The relevant light turns on or off when opening and closing the glove compartment or trunk lid.

Ambient lighting

Depending on vehicle equipment, ambient lighting can provide indirect lighting in various areas of the vehicle interior.

The footwell can also be illuminated.

The brightness and, depending on the equipment, the color of the ambient lighting, can be adjusted in the vehicle settings in the Infotainment system ⇒ [Vehicle settings menu](#). If you select the setting Auto, the color of the ambient lighting changes depending on the driving mode setting.

Depending on the vehicle equipment: To increase or reduce the brightness of the ambient surface lighting in the roof console, briefly press the  button in the r console. You can adjust the brightness of the ambient surface lighting in the vehicle settings in the Infotainment system ⇒ [Vehicle settings menu](#).

 After the ignition has been switched off, the lights will turn off when the vehicle is locked or automatically after a few minutes. This reduces the risk of the 12 V vehicle battery being drained.

Visibility

Window wipers

Operating the windshield wiper lever

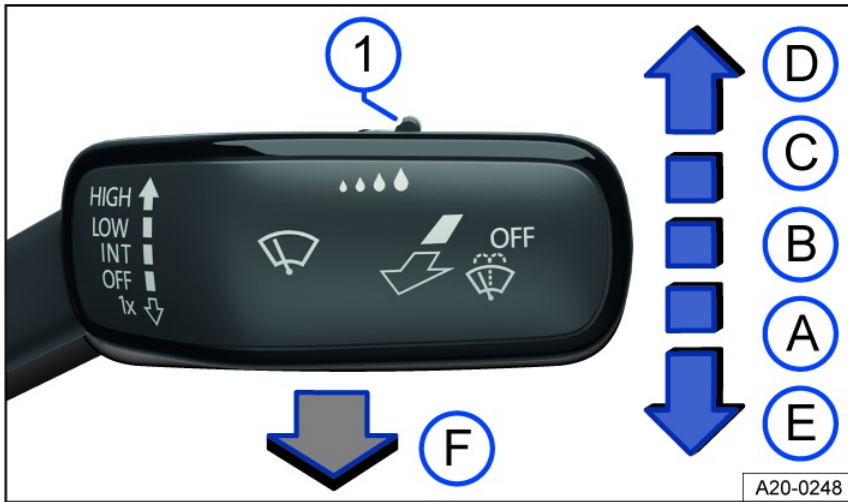





Fig. 84 On the right side of the steering column: operating the windshield wipers.

The windshield wipers only work when the ignition is switched on and the hood is closed. Move the wiper lever into the desired position ⇒ :

- A OFF** Wipers are switched off.
- B INT** Interval wiping for the windshield or rain sensor mode. Interval wiping for the windshield depends on the driving speed. The higher the speed, the faster the wipers will move.
- C LOW** Slow wiper speed.
- D HIGH** Fast wiping.
- E 1x** One-tap wiping – brief wiping. Press and hold the lever down longer to wipe faster.
- F**  Pull the lever to activate the automatic wiper/washer system to clean the windshield. While the wiper/washer system is active, the Climatronic system switches to recirculation mode for approximately 30 seconds to help prevent the washer fluid odor from entering the vehicle interior.
- 1**  Switch for interval levels (vehicles without rain/light sensor) or to adjust the sensitivity of the rain/light sensor.

WARNING

Without the sufficient freeze protection, washer fluid can freeze on the window glass and reduce visibility.

- Only use the washer system with sufficient freeze protection in winter temperatures.
- Never use the windshield washer system in winter temperatures if the windshield has not been warmed up, e.g. with the air conditioning system. Otherwise, the freeze protection mixture can freeze on the windshield and limit visibility.

WARNING

Worn or dirty wiper blades reduce visibility and increase the risk of accidents and serious injuries.

- Always replace wiper blades if they are damaged or worn and are no longer cleaning the window glass sufficiently ⇒ [Cleaning and changing wiper blades](#).

NOTICE

Incorrect handling of the windshield wipers can cause damage to the windshield, the wiper blades and the wiper motor.

- Before driving and before the ignition is switched on, check that the windshield wiper lever is in the basic position.
- Remove any snow – and ice from the windshield wipers and the windshield.
- Always carefully loosen wiper blades that have frozen onto the windshield from the windshield.

NOTICE

Do not use the windshield wipers when the windshield is dry. The window glass can be damaged if wiper blades wipe a dry window.

- Do not turn on the windshield wipers when the windshield is dry.

 The activated wiper speed temporarily changes to the next lower speed when the vehicle is stationary.

 When parking the vehicle in cold weather conditions, moving the windshield wipers to the service position may be helpful for loosening the wiper blades more easily from the windshield ⇒ *Putting the windshield wipers in the service position* .

Wiper function

Heated washer nozzles

The heat thaws frozen washer fluid nozzles. The heat output is automatically regulated when the ignition is switched on and is dependent on the outside temperature. Only the window washer nozzles are heated and not the washer fluid hoses.

Rain/light sensor



Fig. 85 On the right side of the steering column: windshield wiper lever.

- ① Switch for adjusting the sensitivity of the rain/light sensor.
- Ⓐ Rain/light sensor deactivated.
- Ⓑ Rain/light sensor activated, automatic wiping as necessary.

When switched on, the rain/light sensor automatically shortens or lengthens the delay between wiping cycles depending on how hard it is raining.

Activating and deactivating the rain/light sensor

1. Press the lever into the desired position *fig. 85*.

Automatic wiping can be activated and deactivated in the vehicle settings in the Infotainment system ⇒ *Vehicle settings menu*.

If automatic wiping is deactivated in the Infotainment system, the interval time will be set in fixed stages.

Adjusting the sensitivity of the rain/light sensor

The sensitivity of the rain/light sensor can be manually adjusted with the switch in the windshield wiper lever *fig. 85* , ⇒ .

- Move the switch to the right – high sensitivity.
- Move the switch to the left – low sensitivity.

WARNING

The rain/light sensor cannot detect all precipitation sufficiently and activate the windshield wipers accordingly.

- If necessary, switch on the windshield wipers manually if water on the windshield is impairing visibility.

Troubleshooting

Washer fluid level too low

The yellow indicator light turns on.

1. Fill the washer fluid reservoir ⇒ *Washer fluid*.

Windshield wiper malfunction

The yellow indicator light turns on.

The windshield wipers are not working.

1. Switch the ignition off and on.
2. If the malfunction persists, contact a suitably qualified professional. Volkswagen recommends contacting an authorized Volkswagen dealer or authorized Volkswagen Service Facility.

Rain/light sensor malfunction

The yellow indicator light turns on.

The windshield wipers will not be automatically activated in rain/light sensor mode when it is raining.

1. Switch the ignition off and on.
2. If the malfunction persists, contact a suitably qualified professional. Volkswagen recommends contacting an authorized Volkswagen dealer or authorized Volkswagen Service Facility.

Changes to rain/light sensor reaction

Some possible reasons for malfunctions and misinterpretations in the sensor area of the rain/light sensor ⇒ *View from the front* could be:

- **Damaged wiper blades:** damaged wiper blades can leave a film of water or streaks on the window, and this can extend the activation time, greatly shorten the wiper intervals, or cause fast wiping time.
- **Insects:** insects hitting the windshield may trigger the wipers.
- **Salt streaks:** salt streaks on the windshield from driving in the winter can cause the wipers to wipe more frequently or continuously on a window that is almost dry.
- **Dirt:** dried dust, wax, any other build-up on the windshield (lotus effect), or washing product residue (car wash) can lower the sensitivity of the rain/light sensor and cause it to react too slowly or not at all. Clean the sensor area for the rain/light sensor regularly and check the wiper blades for damage ⇒ *Exterior care and cleaning*.
- **Crack in the windshield:** if a stone strikes and chips the sensor area while the rain/light sensor is on, this will trigger a wiper cycle. After that, the rain/light sensor will detect this irregularity on the sensor surface and react to it. Depending on the size of the chip, the reaction behavior of the rain/light sensor may or may not change.

 **If there is an obstacle for the wipers on the window glass, the wipers will attempt to remove it. If it continues to block the wipers, the wipers will stop moving.**

1. Remove the obstacle and switch the wipers on again.

Mirrors

General safety precautions

Using the outside mirrors and the interior rearview mirror, the driver can observe traffic and adjust their driving based on traffic.

For driving safety, it is important that the driver adjusts the outside mirrors and the interior rearview mirror correctly before starting to drive.

It is not possible to oversee the entire side and rear area of the vehicle by looking in the outside and interior rearview mirrors. These areas that are not visible are called blind spots. Other road users and objects could be in the blind spot.

WARNING

Adjusting the outside mirrors and interior rearview mirror while driving can distract the driver. This can cause accidents and serious injuries.

- Only adjust the outside mirror and interior rearview mirror when the vehicle is stationary.
- When parking, changing lanes, passing, and turning, always pay attention to your surroundings, because other road users and objects could be within the blind spot.
- Always make sure that the mirrors are adjusted correctly and visibility to the rear is not limited by ice, snow, fog, or other objects.

WARNING

Inaccurate prediction of distance to vehicles behind you can cause accidents and serious injuries.

- Curved mirror surfaces (convex or aspheric) enlarge the field of vision and allow objects in the mirror to appear smaller and farther away.
- Using the curved mirrors to estimate the distance from vehicles behind you when changing lanes is imprecise and may cause accidents and serious injuries.
- Use the interior rearview mirror as much as possible to more accurately determine the distance to vehicles or other objects behind you.
- Make sure there is sufficient visibility of the area behind the vehicle.

⚠ WARNING

An automatic dimming rearview mirror contains an electrolyte fluid that can leak out if the mirror glass breaks.

- The leaking electrolyte fluid can irritate the skin, eyes, and respiratory organs, especially in individuals with asthma or similar illnesses. Immediately try to exit the vehicle to get fresh air. If this is not possible, open all the windows and doors.
- If the electrolyte fluid comes into contact with eyes or skin, wash the affected area immediately for at least 15 minutes with plenty of water and seek medical assistance.
- If the electrolyte fluid comes into contact with your shoes or clothing, wash it for at least 15 minutes with plenty of water. Clean the shoes and clothing thoroughly before wearing them again.
- If electrolyte fluid is swallowed, rinse out the mouth immediately for at least 15 minutes with plenty of water. Do not induce vomiting unless it ordered to do so by a doctor. Call for medical assistance immediately.

ⓘ NOTICE

If the glass on an automatic dimming mirror breaks, electrolyte fluid can leak out. This fluid damages plastic surfaces.

- Remove any leaking fluid as soon as possible, for instance using a wet sponge.

Interior rearview mirror

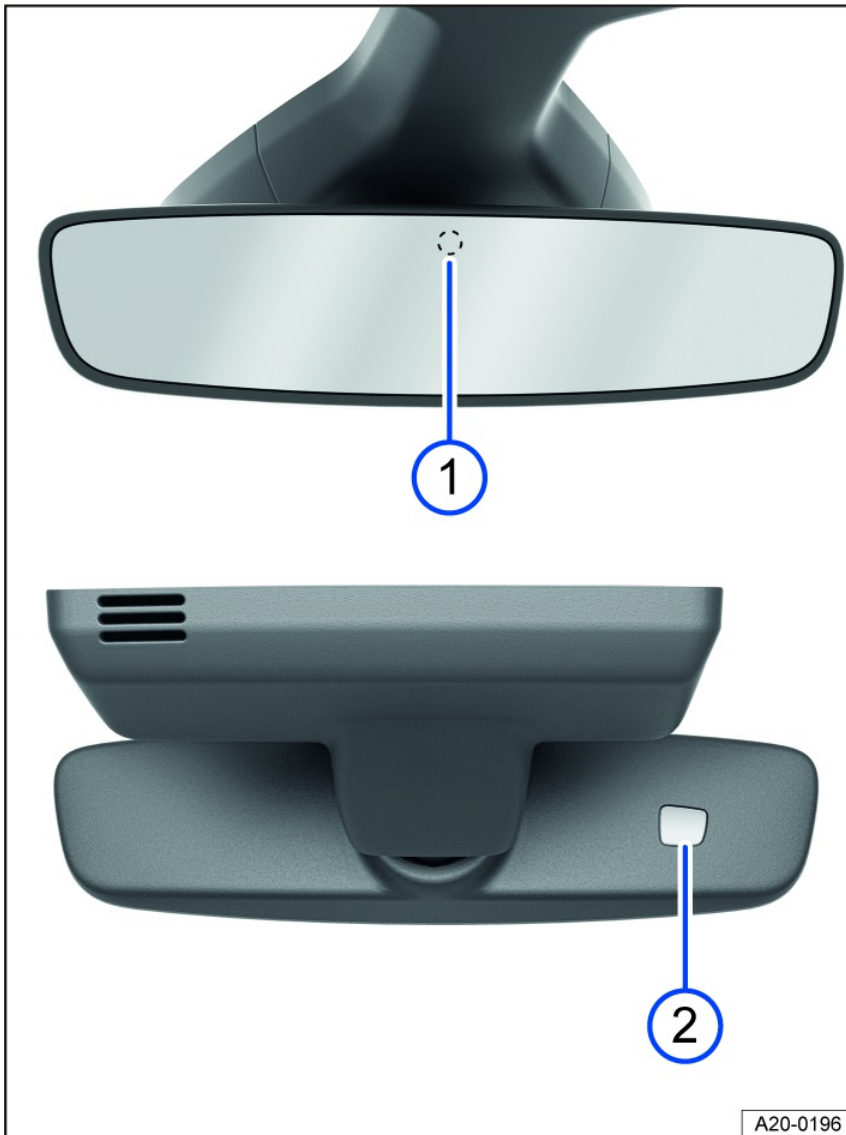

Fig. 86 On the windshield: automatic dimming interior rearview mirror.

- ① Sensor for light entering from the rear.
- ② Sensor for light entering from the front.

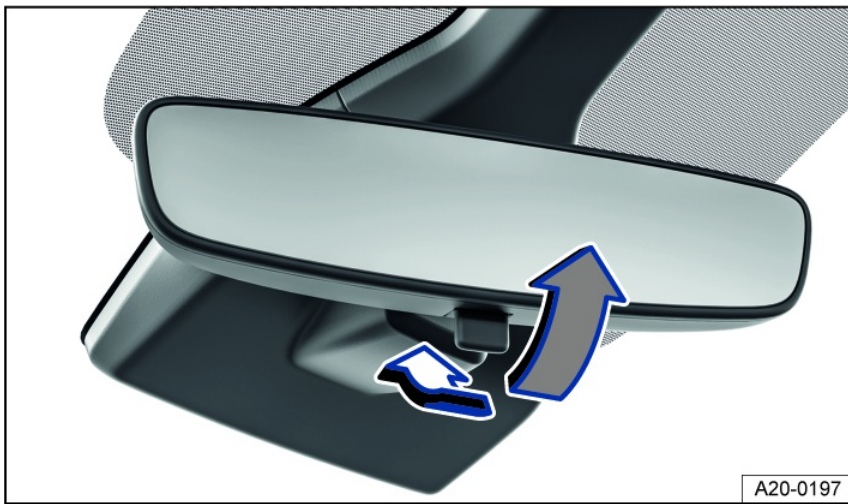

Fig. 87 On the windshield: manual dimming interior rearview mirror.

Automatic dimming interior rearview mirror

When the ignition is on, the sensors measure the amount of light entering from the rear *fig. 86* ① and from the front ②.

Depending on the measured values, the interior rearview mirror will dim automatically.

If the amount of light entering the sensors is limited or interrupted, for example by a sunshade or attachment, the automatic dimming interior rearview mirror may not function or may malfunction. Mobile navigation devices on the windshield or near the automatic dimming interior rearview mirror can also affect the sensors ⇒ ⚠.

Automatic dimming will be deactivated in some situations, for example when reverse gear is engaged.

Manual dimming interior rearview mirror

- Base position: lever on the lower edge of the mirror points forward toward the windshield.
- To dim, pull the lever back *fig. 87*.

⚠ WARNING

The illuminated display on a mobile navigation device can cause the automatic dimming interior rearview mirror to malfunction, which can result in accidents and serious injuries.

- If the automatic dimming function malfunctions, it may not be possible to use the interior rearview mirror to evaluate the exact distance to vehicles or other objects behind the vehicle.

Outside mirrors

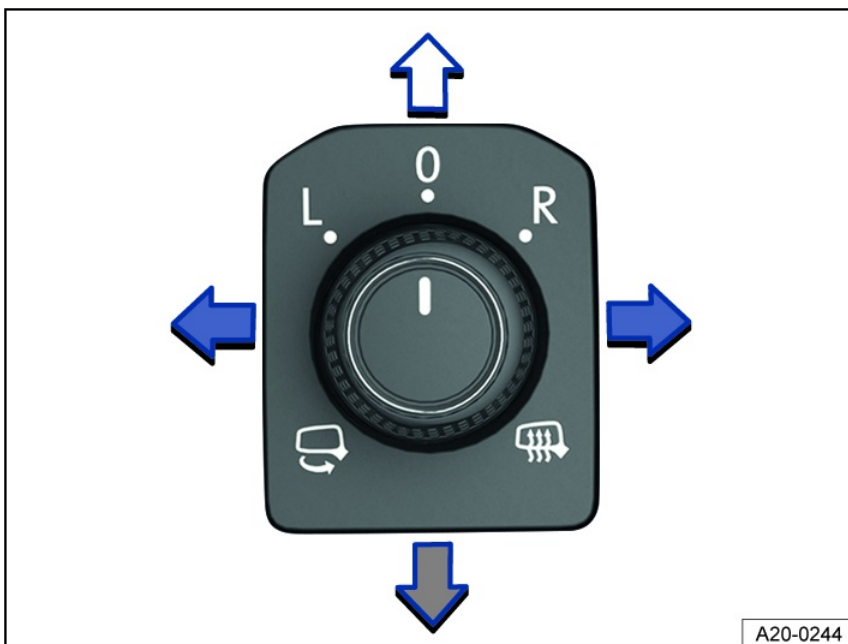



Fig. 88 In the driver door: knob for the outside mirrors.



The following information describes the outside mirror functions for left-hand drive vehicles. Position **L** corresponds to the outside mirror on the driver's side, and position **R** corresponds to the outside mirror on the passenger's side. For right-hand drive vehicles, proceed in the reverse order.

Adjusting outside mirrors

1. Switch the ignition on.
2. Turn the knob in the driver door to the preferred symbol [fig. 88](#).
3. To adjust the outside mirror, push the knob forward, back, right or left in the direction of the arrow.

The scope and the representation of the controls in the driver door vary depending on the vehicle equipment:

 Fold the outside mirror in towards the vehicle body ⇒ .

 Fold the outside mirror in towards the vehicle body ⇒ .

 Switch on the outside mirror heating. The exterior mirror heating only works when the ambient temperature is below approx. 20 °C (around 68 °F) and provides the most heat when it first turns on. After about two minutes, the mirrors will be heated depending on the ambient temperature.

L Adjusts the left outside mirror.

R Adjusts the right outside mirror.

0 Neutral position. The outside mirror cannot be adjusted and all functions are switched off.

Activating outside mirror functions

The following outside mirror functions must be activated in the vehicle settings in the Infotainment system before they are used for the first time ⇒ [Vehicle setting menu](#).

Synchronized mirror adjustment

The synchronized mirror adjustment feature simultaneously adjusts the right-side outside mirror to match adjustments to the left-side outside mirror.



1. Turn rotary knob to position **L**.
2. Adjusts the left outside mirror. The right outside mirror will be adjusted the same way (synchronized).
3. To correct the adjustment of the right outside mirror, if necessary, turn the knob to the **R** position and adjust the right outside mirror.

Automatic dimming exterior rearview mirror on the driver side

The automatic dimming exterior rearview mirror is controlled together with the automatic dimming interior rearview mirror ⇒ [Interior rearview mirror](#).

Folding the outside mirrors in while parking

If the vehicle is locked or unlocked from the outside, the outside mirrors will automatically fold in or out. For this to happen, the knob must be in the , **L**, **R** or **0** position.

If the knob for power exterior mirrors is in the  or  position, the outside mirrors will remain folded in.

Save the passenger-side outside mirror settings when reversing

1. Unlock the vehicle using the key, to which the setting is allocated.
2. Set the electronic parking brake.
3. Switch the ignition on.
4. Shift the transmission to neutral.
5. Select the reverse gear.
6. Adjust the front passenger outside mirror so that, for example, the edge of the curb can be seen clearly.
7. Shift the transmission to neutral.
8. Switch the ignition off.

The selected mirror position will be stored and assigned to the vehicle key.

Opening the front passenger outside mirror settings for driving in reverse

1. Turn rotary knob for the outside mirrors to the relevant position for adjusting the front passenger outside mirror.
2. With the ignition switched on, select reverse gear.

The front passenger outside mirror will adjust to the stored position.

The front passenger outside mirror will exit the position stored for driving in reverse when you begin driving forward faster than about 15 km/h (about 9 mph) or when the knob is turned to any other position.

WARNING

Inattentively folding the outside mirrors out and in can cause injuries.

- Do not fold the outside mirrors out or in if there are any obstacles in the path.
- Always make sure your fingers do not get pinched between the outside mirror and the mirror base when moving the mirror.

NOTICE

If outside mirrors are not folded in when driving through a car wash, they can get damaged.

- Always fold in the outside mirrors.
- Do not fold power outside mirrors in or out by hand because the mirror motor could be damaged.

🍃 Leave the outside mirror heating on only as long as it is needed. Otherwise fuel will be used unnecessarily.

🔧 If there is a malfunction in the power outside mirror, you can adjust the position of the mirror manually by hand by pushing on the edge of the mirror surface.

Sunshade

Sun visors

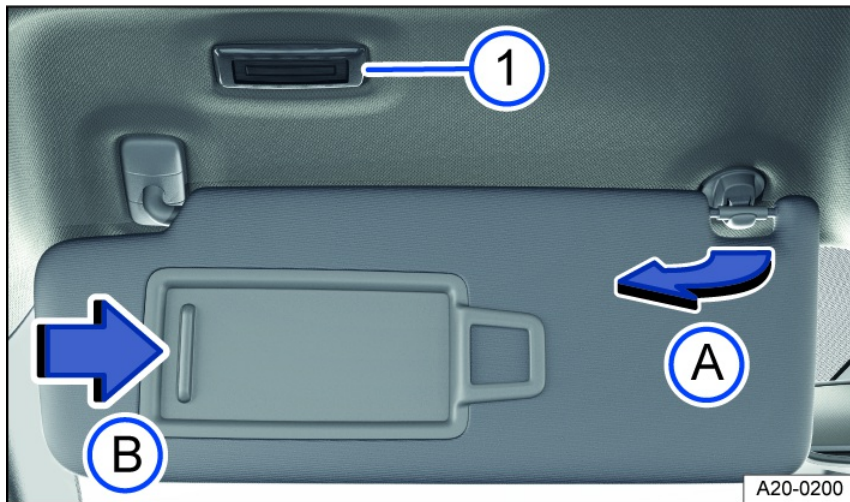

Fig. 89 In the front of the headliner: sun visor.

- ① Light.
- Ⓐ Remove from holder.
- Ⓑ Slide cover open.

Adjustment options for the sun visors

- Fold toward the windshield.
- Remove from the holder and tilt toward the door *fig. 89*.

Adjustment options for the sun visor

In some vehicle models, the sun visor can be moved farther toward the rear when it is tilted toward the door.

Illuminated vanity mirror

When the sun visor is folded down, there is a vanity mirror located behind a cover. The lights *fig. 89* turn on when the cover *fig. 89* slides open.

The lighting for the vanity mirror switches off in the following situations:

- The cover is closed.
- The sun visor is swung upwards or fully forwards.
- The sun visor is pushed in a longitudinal direction or not fully pushed in.

WARNING

Visibility may be reduced when sun visors are folded down and the sunshades are extended.

- Always guide sun visors and sunshades back into their holders when they are no longer needed.

🔧 Under certain conditions, the light above the sun visor will turn off automatically after several minutes. This reduces the risk of the 12 V vehicle battery being drained.

Windshield with communication window



Fig. 90 Next to the mirror base: Communication window (general example).

Windshields made of heat protection glass may have an infrared-reflecting coating and may, depending on the vehicle equipment, be able to be wirelessly heated. In order to ensure that wireless equipment from the accessories industry, e.g. toll systems, can function correctly, an uncoated area is present on either side of the interior rearview mirror (communication window) *fig. 90*.

The uncoated areas must not be covered from the inside or outside, or have stickers on them, because this could cause malfunctions.

Heating and air conditioning system

Climatronic

Overview of the Climatronic

Automatic air conditioner

Climatronic is an automatic air conditioning system which warms, cools and dehumidifies the air. In automatic mode, Climatronic can automatically control the air temperature, air distribution and the volume of air.

The air conditioner is most effective when the vehicle interior is kept closed. If there is a build-up of heat inside the vehicle, ventilation can help to speed up the cooling process.

Some functions of the air conditioner, as well as a climate control bar for the rear seats, depend on the vehicle equipment.



Fig. 91 In the upper section of the center console: air conditioning block for the Climatronic system (version 1).



Fig. 92 In the upper section of the center console: air conditioning block for the Climatronic system (version 2).

Display of activated functions

Illuminated LEDs on the climate control bar indicate that the function is activated.

In the Air conditioner menu in the Infotainment system, function keys highlighted in color indicate that a function is switched on ⇒ [Air conditioner menu in the Infotainment system](#).

⚠ WARNING

Poor visibility through the windows increases the risk of collisions and accidents that can cause serious or fatal injuries.

- Keep all windows free of ice, snow and fog.
- Adjust the heating, air conditioner, and rear window defroster to a setting where the windows do not fog up ⇒ [Troubleshooting](#).
- Only start driving when all windows are clear.
- Only use recirculation mode for a short time. Otherwise, the windows could fog up very quickly and greatly reduce visibility.
- Always switch off recirculation mode when it is not necessary.

Air conditioner menu in the Infotainment system

On the climate control bar

MENU Open the Air conditioner menu in the Infotainment system.

The Air conditioner menu in the Infotainment system is only available via the Climatronic. Certain functions depend on the vehicle equipment.

In the Air conditioner menu, you can find, for example, the functions for temperature regulation ⇒ *Temperature regulation* and air distribution ⇒ *Air distribution and blower speed*.

The top of the screen shows the current climate control settings, such as the air conditioner profile for automatic mode.

The lower section of the screen shows function keys for frequently used air conditioning functions.

Operating status of the air conditioner

The operating status of the air conditioning system is represented by colors:

 Cooling.  Heating.

Climate control settings submenu

 Open the Climate control settings submenu.

Depending on the vehicle equipment, you can find additional comfort functions in the Climate control settings submenu:

Switching the Climatronic on and off

In the air conditioner menu or on the climate control bar

OFF Switch off the Climatronic.  Adjust the blower speed.

1. To switch on the Climatronic, swipe towards the right on the touch slider for the blower speed.

Or: Turn the center knob clockwise.

2. To switch off the Climatronic, swipe towards the left on the touch control for the blower speed.

Or: Turn the center knob counterclockwise as far as it will go.

Automatic mode of the Climatronic

In the air conditioner menu or on the climate control bar

AUTO The set air temperature is maintained constant. The air volume and air distribution are automatically controlled. Automatic mode switches off when the blower speed is changed manually.

Selecting the air conditioner profile

The blower power in automatic mode can be controlled via the air conditioning profiles.

1. Open the air conditioner menu.
2. Tap **AUTO**.
3. To select an air conditioner profile, tap  at the top of the screen.
4. Select your preferred air conditioner profile in the pop-up window.

Temperature regulation



In the air conditioner menu or on the climate control bar

  Adjust the temperature. **A/C** The air is cooled and dehumidified in cooling mode. **SYNC** Apply temperature settings for the driver side to all seats. **MAX A/C**

Switch the maximum cooling output on and off.

Air recirculation is switched on automatically and Climatronic automatically directs air to the upper body.

Setting the temperature on the Climatronic climate control bar



1. To set the temperature of the Climatronic to +72 °F (+22 °C), tap and hold the touch control in the center between  and .

Or: to set a different temperature, swipe to the right or left on the touch control.

Or: turn the left or right knob to  or .

The Climatronic displays the set temperatures.



Maximum cooling output and heating output

1. Tap and hold  or  on the Climatronic touch control.

Or: Turn the left or right knob of the Climatronic system to  or  as far as it will go.



Or: To switch on the maximum cooling output of the Climatronic system, press  on the climate control bar.

Adjusting the temperature for the rear seats

1. Open the Air conditioner menu in the Infotainment system.
2. Tap the function key for the rear seats.
3. Tap the  or  function key.

Or: tap  or  on the climate control bar for the rear seats.

The set temperatures for the rear seats are shown on the climate control bar displays for the rear seats.

 If  is activated in the Infotainment system, the rear climate control bar cannot be used.

Air distribution and blower speed

Vents

Vents are located in the following places in the vehicle:

- Driver's side.
- Passenger's side.
- Front center console.
- Rear center console.

NOTICE

Food, medication, and objects that are sensitive to heat or cold can become damaged or unusable from the air coming out of the vents.

- Do not place any food, medication, or other objects that are sensitive to temperature in front of the vents.

Air distribution functions in the Air conditioner menu on the climate control bar

 Adjust the blower speed.  Top arrow: Direct air onto the windshield.

Middle arrow: Direct air to the upper body.

Bottom arrow: Direct air into the footwell.

 Direct air to the upper body.  Direct air into the footwell.  Direct air onto the windshield.

Defrost function

Switching defrost on and off

  The Climatronic defrost function clears fog and ice from the windshield.

The air is dehumidified and the blower is set to a higher speed.

Air recirculation

Switching air recirculation on and off in the Air conditioner menu or climate control bar

 No fresh air will enter the vehicle interior when recirculation mode is switched on.

1. Press  on the climate control bar.

When does recirculation mode switch off?

Recirculation mode will switch off in the following situations ⇒ :

- If the defrost function is switched on.
- If a sensor detects that the windows could fog up.

WARNING

Lack of air circulation can lead to sudden driver fatigue and lack of concentration, which can cause collisions, accidents, and serious injuries.

- Never use recirculation mode for long periods of time, because this prevents fresh air from entering the passenger compartment.
- Only use recirculation mode for a short time. Otherwise, the windows could fog up very quickly and greatly reduce visibility.
- Always switch off recirculation mode when it is not necessary.

NOTICE

Do not smoke in the vehicle when recirculation mode is switched on. The smoke can settle on the refrigerant system evaporator and the active combination filter and cause permanent odors.



 Climatronic: When reverse gear is engaged or while the automatic wash and wipe system is on, recirculation mode switches on automatically so that no odors will enter the vehicle interior.

Seat heating and seat ventilation

Switching the seat heating and seat ventilation on and off in the Air conditioner menu or in the climate control bar

The seat heating and seat ventilation function when the engine is running. The front seats and outer rear seats may be heated in three stages → . The front seats may also be ventilated from inside in three stages.

The seat ventilation function ventilates the seat using vehicle interior air. This removes moisture from the body. The seat itself is not cooled directly.

 **Switch seat heating on and off.**  **Switch seat ventilation on and off.**







If you switch off the ignition, the seat heating and seat ventilation are also switched off. If you switch on the ignition again within ten minutes, the last heating level or ventilation level selected for the driver seat is also automatically activated.

Heating and ventilation levels







The seat heating and seat ventilation are represented by colors:

- At the highest heating or ventilation level, all three LEDs light up.

Using the seat heating function

1. In order to switch on the seat heating at the highest heating level, press the  or  button in the climate control bar.
2. To set the heating level, press the  button or the  button repeatedly.
3. To turn off the seat heating, press the  or  button repeatedly until the LEDs turn off.

Using the seat ventilation function

1. In order to switch on the seat ventilation at the highest ventilation level, press the  or  button in the climate control bar.
2. To set the ventilation level, press the  or  button repeatedly.
3. To turn off the seat ventilation, press the  or  button repeatedly until the LEDs turn off.

When should the seat heating and seat ventilation not be switched on?

Do not switch on the seat heating and seat ventilation under any of the following conditions:

- The seat is occupied by a person with a limited perception of pain or temperature → .
- The seat is not occupied
- The seat is covered with a seat cover
- A child restraint is installed on the seat
- The seat surface is damp or wet
- Seat heating only: The interior or exterior temperature is higher than +77 °F (+25 °C).

WARNING

Magnetic fields are generated when the seat heating is operated. In individual cases, these magnetic fields can affect active medical implants (e.g. pacemakers).

- Wearers of an active medical implant should consult their doctor or the manufacturer of their implant before operating the seat heating.
- If necessary, make your vehicle occupants aware of this as well.

WARNING

People who cannot perceive pain or temperature or who have a limited perception of these due to medication, paralysis, or chronic illnesses such as diabetes could develop burns or undercooling on the back, buttocks, and legs when using seat heating or seat ventilation. Such injuries could take a very long time to heal or may never heal completely. Contact a medical doctor for questions about personal health conditions.

- People with a limited perception of pain and/or temperature must never use the seat heating and seat ventilation functions.

WARNING

If the seat cover is soaked through, this can cause the seat heating to malfunction and increase the risk of burns.

- Make sure the seat surface is dry before using the seat heating function.
- Never sit on the seat while wearing damp or wet clothing.
- Do not place any damp or wet objects and clothing on the seat.
- Do not pour any fluids on the seat.

NOTICE

- To prevent damage to the seat heating elements, never kneel on the seats or exert pressure on the seating surface and backrest with sharp or pointed

objects.

- Fluids, sharp objects, and insulating materials, for example a protective cover or child restraint, can damage the seat heating function.
- If any odor starts to develop, turn off the seat heating immediately and have it checked by suitably qualified professionals. Volkswagen recommends contacting an authorized Volkswagen dealer or authorized Volkswagen Service Facility.
- If the original seat cover is replaced with a different material, the seat heating may overheat or the operation of the seat heating may be restricted.

 In order to save fuel, switch off the seat heating and seat ventilation as soon as possible.

Steering wheel heating

Switching steering wheel heating on and off via the multi-function steering wheel



 Switch steering wheel heating on and off.

The steering wheel heating only works when the engine is running.

Heating levels for the steering wheel heating



When you switch on the steering wheel heating, the current heating level is constantly displayed in the instrument cluster as a bar display. At the highest heating level, all three bars are filled.

Operating steering wheel heating

1. To switch on steering wheel heating at the highest heating level, press the  button.
2. To adjust the heating level, press the  button repeatedly.
3. To switch off steering wheel heating, press the  button repeatedly until the bar display in the instrument cluster display turns off.

If you start the engine again within approximately ten minutes, the last heating level set is automatically switched on.

Saving the heating level

1. Switch on the steering wheel heating and set the desired heating level.
2. To save the current heating level, press and hold the  button for approximately one second.
The heating level is saved and the steering wheel heating is switched off.
3. To switch the steering wheel heating back on at the most recently saved heating level, press and hold the  button for approximately one second.

Steering wheel heating switches off automatically

If one of the following conditions applies, the steering wheel heating switches off automatically:

- If the energy use is too high.
- If the steering wheel heating system is malfunctioning.

Rear window defroster

Switching the rear window defroster on and off in the Air conditioner menu or climate control bar

 Switch the rear window defroster on and off while the engine is running.

The rear window defroster switches off automatically after a maximum of around ten minutes.

NOTICE

To reduce the risk of damage to the rear window defroster, do not apply any stickers on the heating wires on the inside of the window.

 In order to save fuel, switch off the rear window defroster as soon as possible.

Troubleshooting

The cooling mode or heating cannot be switched on or the function is limited

The  cooling mode only works when the engine is running and at ambient temperatures above +3 °C (+38 °F).

If the engine is very hot or if the outside temperature is extremely high, the function of the cooling mode , the heating and the defrost may be restricted.

- Switch on the fan.
- Check the safeguard on the air conditioning system ⇒ [Replacing fuses](#).
- Change active combination filters ⇒ [Service](#).

- If the malfunction persists, contact a suitably qualified professional. Volkswagen recommends contacting an authorized Volkswagen dealer or authorized Volkswagen Service Facility.

! NOTICE

If the air conditioner is not working, switch it off immediately to prevent subsequent damage. Have the air conditioner checked by suitably qualified professionals. Volkswagen recommends contacting an authorized Volkswagen dealer or authorized Volkswagen Service Facility.

The windows are fogged up

The windows fog up when they are colder than the ambient temperature and the air is very humid. Cold air does not absorb as much moisture as warm air which is why windows fog up more frequently during cold seasons.

1. To improve the heating and cooling output, keep the air intake in front of the windshield free of ice, snow, and leaves ⇒ [Vehicle care](#).
2. Leave the air duct in the rear section of the luggage compartment uncovered so that air can flow through the vehicle from front to back.
3. Switch on the defrost function ⇒ [Defrost function](#).

The temperature unit has changed

1. Changing the temperature units for all temperature displays in the vehicle using the Infotainment system ⇒ [Vehicle settings menu](#).

Water or water vapor under the vehicle

In the case of high outside humidity and temperatures, condensation can drip from the air conditioning system evaporator and pool under the vehicle. This is normal and does not mean there is a leak in the system.

Driving

Messages about driving

Pedals

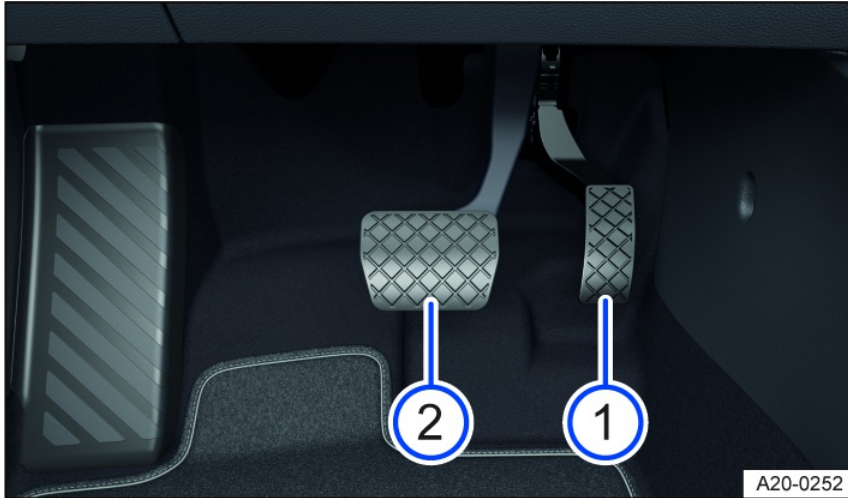

Fig. 93 In the footwell: pedals.

- ① Accelerator pedal.
- ② Brake pedal.

⚠ WARNING

Objects in the driver footwell can prevent the pedals from moving freely. This can cause the driver to lose control of the vehicle and increases the risk of serious injuries.

- Make sure all pedals can always be pressed without obstructions.
- Always attach floor mats securely in the footwell.
- Never place floor mats or other carpet over the installed floor mat.
- Make sure no objects can enter the driver footwell while driving.
- Remove any objects from the footwell when the vehicle is parked.
- Wear shoes that give your feet good grip for operating the pedals.

⚠ WARNING

Always comply with the applicable driving regulations and speed limits and think ahead while driving. Evaluating driving situations correctly can make the difference between safely reaching your destination and being involved in a collision with serious injuries.

- Take regular breaks on long drives. You should take a break at least every two hours.

⚠ WARNING

Driving under the influence of alcohol, drugs, medication, and prescription narcotics can cause serious accidents and fatal injuries.

- Alcohol, drugs, medication, and prescription narcotics can considerably impair perception, reaction times, and driving safety, which can result in loss of vehicle control.

ⓘ NOTICE

It must always be possible to press the pedals with no obstructions. For example, if a brake circuit is malfunctioning, the brake pedal may need to travel farther in order to stop the vehicle. In that case, the brake pedal would need to be pressed down farther and more strongly than normal.

Eco tips

The correct driving style can help to reduce consumption, pollution, and wear on the engine, brakes, and tires. The following tips will help you conserve the environment and your

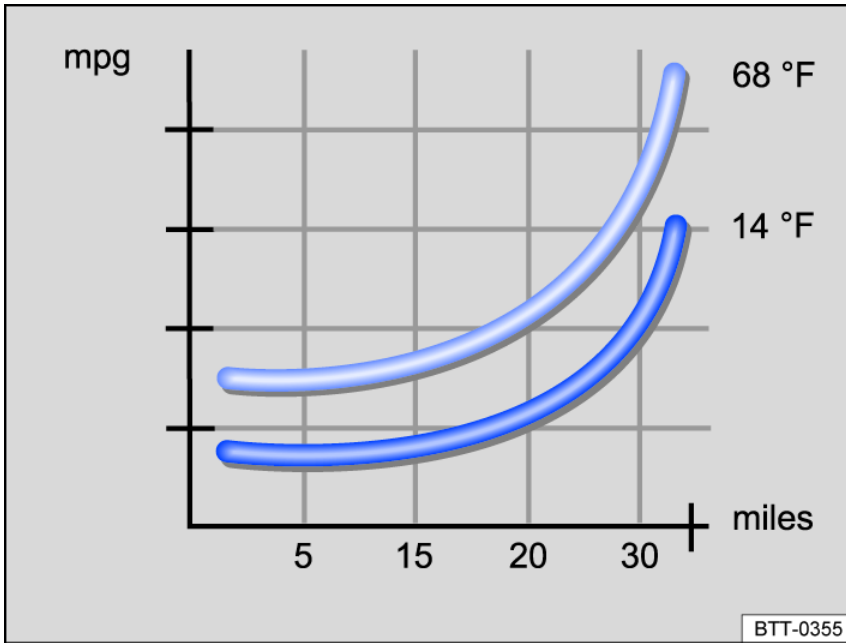

Fig. 94 Fuel consumption in mpg at two different ambient temperatures.

Anticipatory driving

An inconsistent driving style increases consumption. When the driver actively pays attention to traffic, this can prevent frequent acceleration and braking maneuvers. Maintaining enough distance to the vehicle driving ahead helps you to drive with better anticipation.

Using the freewheel function

Vehicles with an automatic transmission: If neither the accelerator nor the brake pedal is pressed in the **D** selector lever position, the vehicle will roll ("coasting feature") without using energy.

How to save energy when shifting gears

Early upshifting saves energy at an engine RPM of 2,000. Do not wait as long as possible to upshift gears and avoid high engine speeds.

- Vehicles with an automatic transmission: Accelerate slowly and avoid using the kick-down function.
- If possible, use the **ECO** driving mode.

Avoiding full acceleration

Excessively high speeds increase the rolling resistance and air resistance and with that, the power needed to move the vehicle. Never drive at the maximum vehicle speed.

Reducing to idle speed

Start driving immediately at low speeds. When stationary for a long time, do not shift to idle, but rather stop the engine, for example when in a traffic jam or at a railroad crossing.

On vehicles with an activated start-stop system, the engine can turn off automatically when the vehicle is stopped and when stationary.

Refuel in moderation

A full fuel tank increases the vehicle weight. A fuel tank that is half to three-quarters full is best suited for city driving.

Avoid short trips

A cold engine has a very high consumption rate. The optimal operating temperature is only reached after several kilometers (miles). When outside temperatures are very low, for example in winter, the consumption is much higher than average [fig. 94](#). Plan trips economically and combine short trips.

Have maintenance performed regularly

Regular maintenance is required for fuel-efficient driving and increases the service life of the vehicle.

Checking tire pressures

Low tire pressures cause wear as well as increased rolling resistance of tires, and this increases consumption. Use tires with optimal rolling resistance.

Adapt the tire pressures to the load:

- Follow the specifications on the tire pressure label ⇒ [Tire pressure](#).
- Tire Pressure Monitoring System ⇒ [Tire Pressure Monitoring System](#).

Using synthetic engine oil

Full synthetic engine oils with a low viscosity reduce the frictional resistance in the engine and distribute significantly better and faster when cold-starting the engine

Removing unnecessary weight

Clearing out the luggage compartment, for example by removing empty crates or unneeded child restraints, can reduce consumption.

To keep the vehicle's air resistance as low as possible, remove attachments after use.

Saving energy

The alternator, which is powered by the engine, generates power for the electrical equipment, such as the climate control system, window heating, or ventilation. Saving energy is simple, for example:

- When temperatures are high, air out the vehicle before driving and drive short distances with the windows open. Then turn on the climate control system.
- Turn off electrical equipment when it is no longer needed.

WARNING

Driving at high altitudes can reduce the engine power due to lower air density. Lower engine power can result in accidents, e.g. when overtaking. This can result in serious injury or death.

- Always adapt your speed and driving style to the visibility, weather, road and traffic conditions.

WARNING

Always adapt your speed and remain a safe distance to vehicles driving ahead according to the visual, weather, road, and traffic conditions.

NOTICE

Never let the vehicle roll down mountains or hills in the **N** neutral setting. The transmission is not lubricated when this happens and this can damage it.

 An authorized Volkswagen dealer or authorized Volkswagen Service Facility can provide you with more information about correct maintenance and replacement parts that are particularly energy efficient, such as new tires.

 In driving situations when less power is required, the engine cylinders can deactivate automatically on vehicles with Active Cylinder Management (ACT), depending on the vehicle equipment. While deactivated, no fuel will be injected into the respective cylinders, which reduces fuel consumption overall.

Information on the brakes

Breaking in brake pads

During the first approx. 200 to 300 km (approx. 100 to 200 miles), new brake pads do not yet have their full braking efficiency and first need to be “worn in” ⇒  However, you can compensate for the slightly reduced braking force by pressing firmly on the brake pedal. During the break-in period, the braking distance during full braking or automatic braking is longer than with brake pads that have been broken in. During the break-in period, avoid full braking and situations that place a heavy load on the brakes, such as driving too close to the vehicle ahead.

Brake pad wear

Brake pad wear depends on driving conditions and style. When driving frequently in cities and on curves or with a sporty driving style, have your brake pads checked frequently by suitably qualified professionals. Volkswagen recommends contacting an authorized Volkswagen dealer or authorized Volkswagen Service Facility.

External influences on the brake

When driving with wet brakes, for example after driving through water, in heavy rain, or after washing your vehicle, the braking efficiency can be reduced by moisture or ice on the brake discs. You must “dry” the brakes as soon as possible by braking carefully at high speeds. Make sure there is no vehicle behind you and that you do not endanger anyone else on the road ⇒ .

A coating of salt on the brake discs and brake pads reduces the braking efficiency and increases the braking distance. If you do not apply the brakes for long periods of time on salt-covered roads, you must brake carefully to clean off the layer of salt ⇒ .

Leaving the vehicle parked for long periods of time, low mileage, and avoiding heavy braking can contribute to corrosion on the brake rotors and dirty brake pads. If you usually avoid heavy braking or if there is corrosion present, occasional heavy braking at high speeds is recommended to clean the brake rotors and pads. Ensure that you do not endanger any other vehicles or anyone else on the road ⇒ .

WARNING

Driving with worn brake pads or a malfunctioning brake system can result in accidents and serious injuries.

- If you suspect that the brake pads are worn or the brake system is malfunctioning, immediately find a suitably qualified professional and have the brake pads checked and worn brake pads replaced. Volkswagen recommends contacting an authorized Volkswagen dealer or authorized Volkswagen Service

Facility.

WARNING

New brake pads have not achieved the optimum braking efficiency yet.

- Up to the first approx. 200 to 300 km (approx. 100 to 200 miles), new brake pads do not yet have their full braking efficiency and first need to be “worn in”. You can make up for the reduced braking efficiency by pressing the brake pedal harder.
- To reduce the risk of accidents, serious injuries, and loss of vehicle control, drive with extra caution when the brake pads are new.
- During the break-in period for new brake pads, do not drive too close to other vehicles and avoid driving situations that place a heavy load on the brakes.

WARNING

Prolonged braking causes the brakes to overheat. This can considerably reduce braking performance, increase braking distance and possibly lead to a total brake system malfunction.

- Never let the brakes “rub” too often and too long or press the brake pedal too often and too long.

WARNING

Overheated brakes reduces the braking efficiency and increase the braking distance considerably.

- When driving downhill, a lot of force is placed on the brakes and they become hot quickly.
- Before driving on a long stretch of road with a steep gradient, reduce your speed by shifting down to a lower gear with a manual transmission or in tiptronic mode of the automatic transmission. This utilizes the engine braking efficiency and reduces the load on the brakes.
- Aftermarket or damaged front spoilers can affect the air supply to the brakes and cause them to overheat.

WARNING

Wet, icy, or salt-covered brakes will take longer to brake and increase the braking distance.

- Test the brakes carefully.
- Always press the brake pedal carefully several times to dry the brakes and clear the ice and salt from them, as long as the visibility, weather, road, and traffic conditions permit.

 **If you are having the front brake pads checked, the rear brake pads should be checked at the same time. Regularly check the thickness of the brake pads visually by inspecting them through the openings in the wheel rims or from underneath the vehicle. If necessary, remove the wheels so that the brake pads can be inspected. For further information, contact an authorized Volkswagen dealer or authorized Volkswagen Service Facility. Volkswagen recommends contacting an authorized Volkswagen dealer or authorized Volkswagen Service Facility.**

Driving a loaded vehicle

Heed the following for good vehicle handling when the vehicle is loaded:

- Stow all cargo securely ⇒ [Transporting](#).
- Accelerate with extra care and caution.
- Avoid sudden braking and driving maneuvers.
- Brake earlier than usual.
- If necessary, read and heed the information about roof racks ⇒ [Roof rack](#).
- If necessary, note the information about driving with a trailer ⇒ [Trailer towing](#).

WARNING

Sliding loads can considerably impair the driving stability and safety of your vehicle, increase the braking distance when you brake hard or perform an emergency stop, and thus increase the risk of accidents and serious injury.

- Correctly secure the load to prevent it from sliding.
- Use suitable tie-downs or securing straps on heavy objects.
- Engage the rear seat backrests and, if necessary, the adjustable rear seats securely.

Driving with an open trunk lid

Driving with an open trunk lid can be especially dangerous. Secure all objects and the open trunk lid correctly and take sufficient precautions to reduce the amount of poisonous exhaust that enters the vehicle.

WARNING

Driving with the trunk lid unlocked or open may cause serious injuries.

- Always drive with the trunk lid closed.
- Store all objects securely in the luggage compartment. Loose objects can fall out of the trunk and injure other road users.
- Always drive carefully and anticipate upcoming traffic situations.
- Avoid abrupt or sudden driving and braking maneuvers because the open trunk lid can move in an uncontrolled manner.
- Mark objects sticking out of the luggage compartment so they will be visible to others on the road. Follow the legal regulations here.
- If objects must stick out of the luggage compartment, never use the trunk lid to “clamp” or “secure” objects.
- If there is a roof rack with cargo on the trunk lid, always remove it before driving with an open trunk lid.

WARNING

Poisonous exhaust fumes may leak into the vehicle interior if the trunk lid is open. This can lead to a loss of consciousness, carbon monoxide poisoning, accidents, and serious injuries.

- To prevent poisonous exhaust from entering the vehicle, always drive with the trunk lid closed.
- If you absolutely must drive with the trunk lid open, take the following precautions to reduce the risk of poisonous exhaust fumes entering the vehicle interior:
 - Close all windows.
 - Close the power sunroof.
 - Switch off recirculation mode.
 - Open all the air vents in the instrument panel.
 - Switch the blower to the highest blower level.

NOTICE

Opening the trunk lid changes the height and possibly the length of the vehicle.

Driving through water on roads

Note the following to reduce the risk of vehicle damage when driving through water, for example on flooded roads:

- The water must not be any higher than the bottom of the vehicle body ⇒ .
- Do not drive faster than walking speeds.
- Never stop the vehicle, drive in reverse, or stop the engine in water.
- Oncoming vehicles create waves that can raise the water level for your vehicle enough that it is not safe to drive through.
- Always manually deactivate the start-stop system when driving through water ⇒ *Start/Stop system*.

WARNING

When driving through water, mud, slush, etc., the braking effect may be delayed due to damp or icy brake rotors and brake pads in the winter, and this can extend the braking distance.

- Perform careful braking maneuvers to dry and remove ice from the brakes. Do not endanger road users or disregard legal regulations when doing so.
- Avoid abrupt and sudden braking maneuvers directly after driving through water.

NOTICE

Driving through water can greatly damage parts of the vehicle, e.g. electrical equipment.

- Never drive through salt water because salt can cause corrosion. Immediately clean any vehicle components that come into contact with salt water using fresh water.

Breaking in the engine

A new engine needs to be broken in during the first 1500 km (approx. 1000 miles). All moving parts should be able to work together. During the first few hours of operation, the engine has a higher internal friction than it will later.

Up to 1000 km (approx. 600 miles)

- Do not accelerate fully.
- Do not use more than two thirds of the maximum engine RPM.
- Do not drive with a trailer.

Between 1000 and 1500 km (approx. 600 to 1000 miles)

1. Increase the speed and engine RPM gradually.

The driving style during the first 1500 km (approx. 1000 miles) also affects the engine's quality. Even after that – especially when the engine is cold – the engine should be driven at moderate engine speeds to reduce engine wear and increase the possible mileage.

 **New tires and brake pads must be carefully broken in.**

NOTICE

Do not drive at an insufficient engine speed. Always downshift if the engine stops running “smoothly”.

 If the new engine is broken in gently, its service life is increased while, at the same time, reducing engine oil consumption.

Operating the vehicle in different countries and continents

Approval regulations

The vehicle was manufactured by the factory for a specific country and meets those approval regulations that were valid at the time of vehicle manufacture.

 **If the vehicle will be used temporarily or for a brief period in another country, then read and observe the following information.**

Safety standards and regulations

Some countries have special safety standards and regulations that differ from the vehicle configuration. Volkswagen recommends obtaining information about legal regulations from an authorized Volkswagen dealer or authorized Volkswagen Service Facility before driving in other countries.

Selling in other countries

If the vehicle is sold in another country or will be used for an extended period in another country, then the applicable legal regulations in that country must be observed.

Certain equipment may need to be installed or removed and functions may need to be deactivated. The scope and types of service may also be affected. This particularly applies if the vehicle is being operated for an extended period in a different climate region.

Functions of the Infotainment system

Due to the many different frequency bands around the world, the Infotainment system installed at the factory may not function in other countries.

NOTICE

- Volkswagen is not responsible for damage to the vehicle caused by substandard fuel, insufficient service, or not using Volkswagen Genuine parts.
- Volkswagen is not responsible if the vehicle does not meet all of the applicable legal requirements in other countries and continents.

Troubleshooting

BRAKE Brake system malfunction

The red warning light turns on. A message may also be displayed.

1.  **Do not continue driving!** Immediately contact an authorized Volkswagen dealer or authorized Volkswagen Service Facility for assistance.

BRAKE WEAR Brake pad wear indicator

The red warning light turns on or flashes.

The front brake pads are worn.

1. Immediately contact an authorized Volkswagen dealer or authorized Volkswagen Service Facility to have the system checked. Volkswagen recommends

contacting an authorized Volkswagen dealer or authorized Volkswagen Service Facility.

2. Have all brake pads inspected and replaced, if necessary.

Unusual noises when braking

If there are sustained scraping or squeaking noises when braking, that is a sign of worn brake pads on the front or rear axle.

1. Immediately contact an authorized Volkswagen dealer or authorized Volkswagen Service Facility to have the system checked. Volkswagen recommends contacting an authorized Volkswagen dealer or authorized Volkswagen Service Facility.
2. Have all brake pads inspected and replaced, if necessary.

If the vehicle's braking performance changes

If the brake pads are worn or if you notice that your vehicle does not brake as usual, e.g. the braking distance suddenly increases:

1. Immediately contact an authorized Volkswagen dealer or authorized Volkswagen Service Facility to have the system checked. Volkswagen recommends contacting an authorized Volkswagen dealer or authorized Volkswagen Service Facility.
2. Have all brake pads inspected and replaced, if necessary.

Starting and stopping the engine

Starter button



Fig. 95 In the lower area of the center console: starter button for starting the engine.

The starter button replaces the ignition lock (Press & Drive).

Vehicles with an automatic transmission: Start the engine with the starter button (Press & Drive) and by pressing the brake pedal.

The vehicle can only be activated when there is a valid vehicle key inside the vehicle.

Depending on the model, the starter button blinks to indicate readiness for use.

The electronic steering column lock is activated when you leave the vehicle by opening the driver's door when the ignition is switched off ⇒ [Steering information](#).

Switching the ignition on or off

1. Vehicles with an automatic transmission: Press the starter button once without pressing the brake pedal ⇒ .

Automatic ignition switch off

If the vehicle recognizes that the driver is absent when the engine is actively stopped, the ignition is automatically switched off after a certain amount of time. If the low beam headlights were switched on at this time, the parking light remains on for around 30 minutes. The parking light can be switched off either by locking the vehicle or manually.

Engine restart function

If no valid vehicle key is detected inside the vehicle after stopping the engine, it can be started again within approximately five seconds. A message about this will be shown in the instrument cluster display.

Once this time has elapsed, the vehicle can no longer be started without a valid vehicle key inside the vehicle.

WARNING

Unintentional vehicle movements can cause serious injuries.

- Do not press the brake or clutch pedal when switching on the ignition or the engine will start immediately.

WARNING

Careless or unintended use of the vehicle key can cause crashes and serious injuries.

- Always switch off the engine and take all vehicle keys with you when you leave the vehicle. Children or unauthorized people could lock the vehicle, start the engine, or switch the ignition on and activate electrical equipment, such as the power windows, which could lead to serious injuries.
- Never leave children or people requiring assistance unattended in the vehicle when the vehicle is locked. In an emergency, they will not be able to leave the vehicle unassisted or care for themselves. For example, depending on the season, the temperature inside the vehicle could become very high or low, which can lead to serious injuries, illness or death, especially for very young children.
- Never start the engine or let it run in unventilated or enclosed spaces. Among other substances, engine exhaust contains carbon monoxide, an odorless and colorless poisonous gas. Carbon monoxide can cause loss of consciousness and death.

 **Always switch the ignition off manually before leaving the vehicle and note any messages in the instrument cluster display.**

 **The vehicle being stationary for long periods with the ignition switched on can cause the 12 V vehicle battery to drain and then it will not be possible to start the engine.**

Starting the engine

Starting the engine

1. Switch the ignition on.
2. Press and hold the brake pedal until the electronic parking brake is switched off.
3. Vehicles with an automatic transmission: Move the selector lever to the **N** position or engage the **P** parking lock.
4. Vehicles with starter button: Press and hold the starter button \Rightarrow *Starter button* and do not press the accelerator pedal. For the engine to start, a valid vehicle key must be inside the vehicle and the brake must be pressed. Release the starter button once the engine starts.
5. If the engine does not start, stop the starting procedure and try again after approximately one minute.
6. Vehicles with starter button: If the vehicle was locked with the vehicle key, the starter button will be deactivated. If you are in the vehicle and you need to start the engine, first unlock the vehicle or perform an emergency start.

WARNING

The risk of serious injuries can be reduced when the engine is running or when starting the engine.

- Never start the engine or let it run in unventilated or enclosed spaces. Among other substances, engine exhaust contains carbon monoxide, an odorless and colorless poisonous gas. Carbon monoxide can cause loss of consciousness and death.
- Never start the engine or let it run if oil, fuel, or other highly flammable operating materials are under the vehicle, near the vehicle, or dripping from the vehicle, for example as a result of damage.
- Never leave the vehicle unattended when the engine is running, especially if a gear is engaged. The vehicle could move suddenly or perform an unusual action, increasing the risk of damage, fires, and serious injuries.
- Never use a start booster. A start booster can explode and cause sudden engine revving.

NOTICE

The starter or engine can be damaged if you try to restart the engine while driving or immediately after switching it off.

NOTICE

Avoid high engine speeds, full acceleration and heavy engine loads when the engine is cold.

NOTICE

At high altitudes, the air density is lower, which can make it more difficult to start the engine.

NOTICE

Do not tow-start or push-start the vehicle. Uncombusted fuel can damage the catalytic converter.

NOTICE

If the engine does not start, e.g. the fuel tank is empty, never use the starter with a gear engaged to drive or to attempt a tow-start. The starter can be damaged.

- If necessary, refill with fuel as per or use jump-start.
- If the engine does not start, contact an authorized Volkswagen dealer or authorized Volkswagen Service Facility. Volkswagen recommends contacting an authorized Volkswagen dealer or authorized Volkswagen Service Facility.

 Do not let the engine run to warm up while the vehicle is parked. Begin driving as soon as there is enough visibility through the windows. This allows the engine to reach its operating temperature sooner and reduces the emissions.

 **Electrical equipment with increased power draw switches off temporarily when the engine is started.**

 **If there is no vehicle key in the vehicle or the key is not detected, a message will appear in the instrument cluster display. This can occur if another signal interferes with the remote control vehicle key or if the remote control vehicle key is covered by an object, such as a metal case.**

 **For example, if the vehicle key button cell battery is weak or drained, the engine cannot be started with the starter button. Perform an emergency start.**

 **After starting, operating noises may be temporarily higher than usual while the engine is cold. This is normal and not a cause for concern.**

Stopping the engine

1. Bringing the vehicle to a stop ⇒ .
2. Park the vehicle.
3. Vehicles with starter button: Press the starter button briefly. If the the engine cannot be turned off, use the emergency stop function.
4. Pay attention to the messages in the instrument cluster.

Exit warning

When the driver door is opened, a warning chime sounds and warning notifications appear in the instrument cluster display to warn you that you are exiting a vehicle that can roll.

WARNING

Never turn the engine off when the vehicle is in motion. That can result in loss of control of the vehicle, accidents, and serious injuries.

- The airbags and safety belt pretensioners will not function.
- Braking support will not work. You must apply more pressure on the brake pedal to stop.
- Power steering will not work. You must use more force to steer.
- Vehicles with starter button: When the ignition is switched off, the steering column lock could engage and you would not be able to steer the vehicle.

WARNING

Exhaust system components will become very hot. This can result in fires and serious injuries.

- Never park the vehicle in such a way that exhaust system components come into contact with flammable materials under the vehicle, for example shrubs, leaves, dry grass, spilled fuel, etc.
- Never use additional undercoating or corrosion protection for exhaust pipes, catalytic converters, heat shields, or particulate filters.

NOTICE

The engine can overheat after turning it off if the vehicle is driven with a high engine load for a long period of time.

- Let the engine run in neutral for approximately two minutes before turning it off to reduce the risk of engine damage.

 **After the engine has been switched off, the radiator fan in the engine compartment can keep running for a few more minutes. The radiator fan will turn off automatically.**

Remote start function

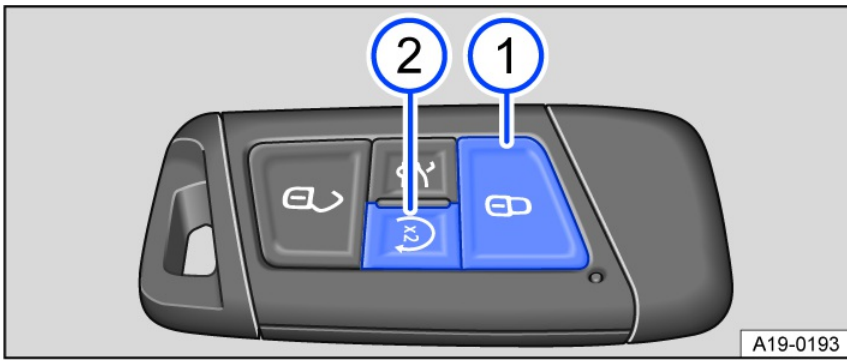

Fig. 96 Vehicle key with remote start relay function.

- ① Button to lock the vehicle.
- ② Button for remote start relay function.

With the remote start relay function, the engine can be started remotely, in order to heat or cool the vehicle interior before the start of a journey.

Starting the remote start relay function

You must press the following buttons on the vehicle key within five seconds to start the engine using the remote start relay function → ⚠:

1. Press the  button once *fig. 96*.

All turn signals will flash.

2. Press the  button twice *fig. 96*.

All turn signals will flash. During remote start, the parking light turns on.

ⓘ If the remote start relay process is not actively canceled by the driver or automatically canceled, the engine will run for around 10 minutes.

A maximum of two remote starts can be performed in a row, even if one or both remote starts have been interrupted within the 10 minute period.

1. In order to carry out two more remote starts, switch the ignition on and off once.

Ending the remote start relay

1. Press the  button on the remote control vehicle key to switch off the engine *fig. 96*.

Driving after a remote start relay

If the engine has been started using the remote start relay function, the vehicle cannot be driven. To transition to being able to drive:

1. Vehicles with starter button: Press the brake pedal and the starter button.

The engine continues to run during this process.

Remote start relay conditions

The following conditions must be fulfilled simultaneously in order for the vehicle interior to be heated or cooled by the remote start relay function:

- The vehicle is fully ready to drive.
- The vehicle does not move.
- Sufficient fuel is available and the indicator light  did not light up before the vehicle was parked.
- The parking lock **P** is engaged.
- All doors, the hood and the trunk lid are fully closed and locked.
- The anti-theft alarm system has not triggered the alarm.
- The panic alarm is not activated.
- The emergency flashers are switched off.
- Two remote starts have not yet been carried out in direct succession.

Settings for automatic air conditioning with remote start relay

Climatronic: After the engine is started, the air conditioner automatically regulates the temperature of the vehicle interior to approx. +22 °C (approx. +72 °F) if it is in automatic mode **AUTO**.

The following heating, ventilation and cooling system settings are automatically applied in the case of a remote start relay, depending on the vehicle equipment:

Active at outside temperatures above approx. +20 °C (approx. +68 °F)

- Front seat ventilation, level 2.

Active at outside temperatures below approx. +15 °C (approx. +59 °F)

- Front seat heating, level 2.

Active at outside temperatures below approx. +20 °C (approx. +68 °F)

- Exterior mirror heating.

Active at temperatures below approx. +4 °C (approx. +39 °F)

- Heated spray jets for windscreen washer system.
- Heated windshield wiper parks.
- Rear window defroster.

If the engine has been started using the remote start relay function, the settings can be changed via the air conditioning system controls and the buttons for the windshield and rear window defroster, seat heating or ventilation, depending on vehicle equipment.

Personal settings will be replaced by the automatic air conditioning settings the next time the vehicle is started using remote start relay.

1. To change the automatic air conditioning settings, contact a suitably qualified professional. Volkswagen recommends contacting an authorized Volkswagen dealer or authorized Volkswagen Service Facility.

WARNING

Careless or unintended use of the remote start relay function can cause serious injuries.

- Never start the engine in an enclosed space, e.g. in a garage. The exhaust can cause fatal poisoning and result in death through suffocation.
- Only use the remote start relay function when no-one is in the vehicle and immediately before you intend to drive the vehicle.
- Never start the engine if children or animals are in the vehicle. When the engine is running, the electrical seats may be used and can cause serious injuries.
- Never start the engine if the vehicle is covered with a protective cover. Hot vehicle components and exhaust can set the protective cover on fire and cause serious injuries.
- Never start the engine close to flammable or explosive materials. The exhaust could ignite the materials. This could cause a fire and serious injuries.
- Never start the engine if the vehicle is out of visual range.
- Never start the engine if the warning light  is turned on or blinking.

 Using the remote start relay function may increase fuel consumption and discharge the 12-volt vehicle battery.

 The use of the remote start relay function may be regulated or prohibited regionally in some countries. Always observe legal and local regulations relating to the use of the remote start relay function!

 During an active remote start relay, some vehicle functions are deactivated, e.g. the low beam headlight and the windshield wipers.

Electronic immobilizer

The immobilizer helps prevent the engine from being started and the vehicle from being moved with an unauthorized vehicle key.

For vehicles with a starter button: There is a chip in the vehicle key. It is used to automatically deactivate the electronic immobilizer when there is a valid remote control vehicle key in the vehicle interior.

For vehicles with a starter button: The electronic immobilizer is automatically activated as soon as there is no valid vehicle key in the vehicle.

The engine can only be started with a Volkswagen Genuine vehicle key that is coded correctly. You can obtain coded vehicle keys from an authorized Volkswagen dealer or authorized Volkswagen Service Facility.

 Only using Volkswagen Genuine vehicle keys will ensure that your vehicle operates correctly.

Troubleshooting



Fig. 97 On the right side of the steering column: emergency start function.

EPC Engine control malfunction

The yellow indicator light turns on.

Engine control is malfunctioning.

1. Pay attention to any text shown in the Volkswagen Digital Cockpit display.
2. Have the engine checked immediately by suitably qualified professionals. Volkswagen recommends contacting an authorized Volkswagen dealer or authorized Volkswagen Service Facility.

EPC Engine control malfunction

The indicator light comes on in the Volkswagen Digital Cockpit.

The yellow indicator light turns on.

The driving performance of the vehicle is limited.

The driving performance has been limited to prevent the engine control components from overheating.

- A corresponding indicator may appear in the instrument cluster display.
- It is possible to continue driving with reduced driving performance.

The driving performance limitation is removed in the following scenarios:

- The engine control components are no longer within a critical temperature range.

! Engine speed limited

The yellow indicator light turns on.

The engine speed has been limited to reduce the risk of the engine overheating.

The instrument cluster display shows the engine speed.

The engine speed limitation is removed in the following scenarios:

- The engine is no longer within a critical temperature range.
- The driver's foot is removed from the accelerator pedal.

! together with **EPC** Engine speed limitation due to engine control malfunction

The yellow indicator lights turn on.

The engine speed limitation is triggered by an engine control malfunction.

1. Make sure the displayed RPM is not exceeded.
2. Have the engine checked immediately by suitably qualified professionals. Volkswagen recommends contacting an authorized Volkswagen dealer or authorized Volkswagen Service Facility.

Valid vehicle key cannot be detected

A corresponding indicator appears in the instrument cluster display.

If the vehicle key has a weak or drained button cell battery, the vehicle key may not be able to be detected.

An emergency start must be performed:

1. Press and hold the brake pedal.
2. Hold the vehicle key on the right side of the steering column trim panel immediately after pressing the starter button *fig. 97*.

The ignition will switch on automatically and the engine may start.

The engine cannot be turned off

The engine cannot be turned off when the starter button is pressed briefly.

An emergency stop must be performed:

1. Press the starter button twice within several seconds or press and hold one time.

The engine will stop automatically → *Starter button*.

The engine cannot be started

If an unauthorized vehicle key is used or the system is malfunctioning, a corresponding indicator appears in the instrument cluster display.

1. Use an authorized vehicle key.
2. If the malfunction persists, contact an authorized Volkswagen dealer or authorized Volkswagen Service Facility.

The engine cannot be started

The engine cannot be started by briefly pressing the starter button while activating the brake pedal or the clutch pedal.

There is a malfunction in the start system.

1. Press the starter button until the engine starts.
2. Contact an authorized Volkswagen dealer or authorized Volkswagen Service Facility for assistance.

The engine cannot be started remotely

If at least one of the following conditions are met, the engine remote start function does not start or the engine switches off when it was running:

- The vehicle is unlocked.
- The hood or the trunk lid is opened.
- The selector lever is not in position **P** ⇒ *Automatic transmission: selecting the selector lever position*.
- The brake or accelerator pedal is pressed.
- During the remote start the fuel level sinks to the reserve amount.
- If the 12-volt vehicle battery is too weak or discharged.
- The switch for the hazard warning lights is pressed.

Ensure that the necessary conditions are met and then restart the engine if necessary.

Start/Stop system

Start-stop system

The start-stop system automatically switches the engine off when you stop and when the vehicle is stationary. The engine starts again automatically when needed.



Fig. 98 In the lower section of the center console: Button for the start-stop system.

Switching on the start-stop system

The function is automatically activated every time the ignition is switched on. Information about the current status is shown in the instrument cluster display.

Further information about start/stop mode can be found in the Infotainment system by pressing the **(MENU)** button or function key and the **(Vehicle)**, **(Selection)**, **(Vehicle status)** function keys.

Indicator lights

When indicator light **(A)** comes on, the start-stop system is available and the automatic engine stop is active.

When indicator light **(A)** comes on, the start-stop system is not available or the start-stop system has automatically started the engine ⇒ .

The start-stop system status can be displayed in the instrument cluster display.

Automatically deactivating and activating the start-stop system

1. Press and hold the brake pedal to stop the vehicle.
The engine turns off shortly before the vehicle becomes stationary.
2. To restart the engine, take your foot off the brake pedal or press the accelerator pedal.

Important conditions for automatic engine switch off

- The driver is wearing their safety belt.
- The driver door is closed.
- The hood is closed.
- A minimum engine temperature has been reached.
- The vehicle interior temperature is within the preset temperature value and air humidity is not too high.
- The air conditioner's defrost function is not switched on.
- The charge level of the 12-volt vehicle battery is sufficient.
- The temperature of the 12-volt vehicle battery is neither too low or too high.
- The vehicle is not on a large uphill or downhill gradient.
- The steering wheel is not significantly turned.
- Reverse gear is not engaged.
- Park Assist is not activated.
- The **S** gear is not engaged.

If the conditions for automatic engine switch-off are only achieved during a stationary phase, then the engine may also switch off at this point, e.g. if the defrost function is switched off.

Conditions for automatic restart

The engine can start automatically under the following conditions:

- If the vehicle interior heats up or cools down significantly.
- If the vehicle starts to move.
- If the electrical voltage in the 12-volt vehicle battery falls.
- If the steering wheel is moved.

In principle the following applies: The engine always restarts automatically when required for the identified situation and vehicle.

Conditions that make manual engine start necessary

The engine must be started manually under the following conditions:

- The driver's door is opened.
- The hood is opened.

Manually deactivating and activating the start-stop system

Manually deactivating the start-stop system:

1. To manually deactivate the system, press the **(A) OFF** button on the center console.

When the start-stop system is deactivated, the indicator light on the button comes on *fig. 98*.

Manually activating the start-stop system:

1. To activate the system manually, press the **(A) OFF** button in the center console again *fig. 98*.

Each time you press the  button, the instrument cluster display indicates the status of the start-stop system.

If the start-stop system has switched the engine off, it restarts as soon as the system is deactivated by pressing the  button.

⚠ WARNING

Never switch off the engine while the vehicle is in motion. That can result in loss of control of the vehicle, accidents, and serious injuries.

- The airbags and safety belt pretensioners will not function.
- Braking support will not work. You must apply more pressure on the brake pedal to stop.
- Power steering will not work. You must use more force to steer.
- When you switch the ignition off, the steering column lock could engage and you would not be able to steer the vehicle.
- Always deactivate the start-stop system when working in the engine compartment.

ⓘ NOTICE

If the start-stop system is used for a very long period of time at very high outside temperatures, this can damage the 12-volt vehicle battery.

 If the temperature is above approx. 38 °C (100 °F), the start-stop system may be automatically deactivated.

 In some cases you may need to restart the engine manually. Pay attention to the relevant message on the instrument cluster display.

 In the case of vehicles with **ECO** Driving Mode Selection, if the driving mode is selected, then the start-stop system is automatically activated.

 Always manually deactivate the start-stop system when driving through water.

Troubleshooting

The engine does not start automatically

1. Start the engine manually ⇒ *Starting the engine*.
2. Manually deactivate the start-stop system ⇒ *Start-stop system*.
3. Contact an authorized Volkswagen dealer or authorized Volkswagen Service Facility to have the system inspected. Volkswagen recommends contacting an authorized Volkswagen dealer or authorized Volkswagen Service Facility.

Automatic transmission

Automatic transmission: selecting the selector lever position

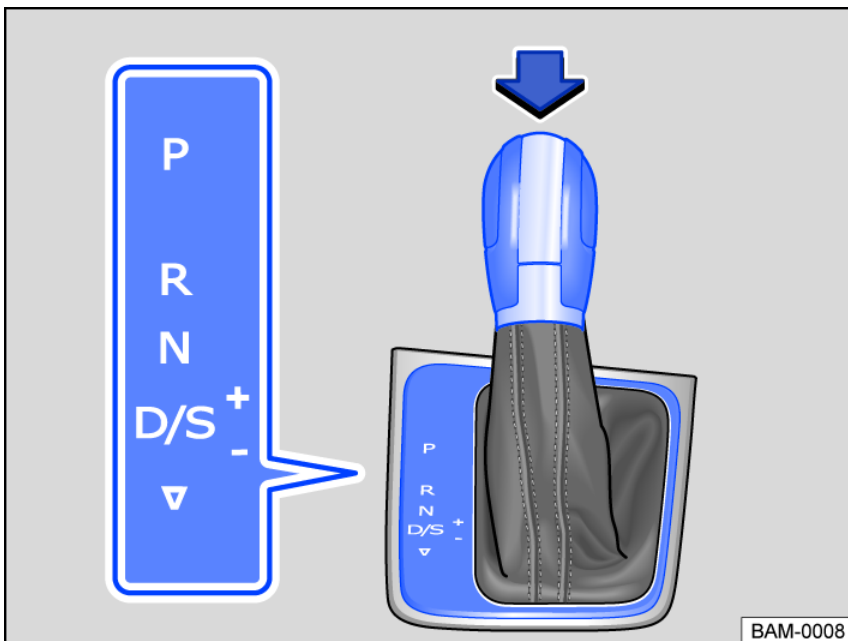

Fig. 99 Selector lever with lock button (arrow) on an automatic transmission.

When the ignition is switched on, the selected gear is shown in the instrument cluster display.

PThe drive gears are locked. Only select this gear when the vehicle is stationary.

To move the selector lever out of this position when the ignition is switched on, press the brake pedal and press the lock button on the selector lever.

RReverse gear is selected. Only select this gear when the vehicle is stationary. **N**The transmission is in the neutral setting. No power is transferred to the wheels

and the engine braking effect is not available. **D/S D** gear: normal program.

The transmission upshifts and downshifts automatically when in the forward driving gears. The shifting time depends on the engine load, the personal driving style, and the driving speed.

S gear: sport program.

The forward gears automatically upshift later and downshift earlier than in **D** gear in order to fully utilize the engine power reserves. The shifting time depends on the engine load, the personal driving style, and the driving speed.

To switch between gears **D** and **S**, tap the selector lever toward the rear ▽.

The selector lever will always spring back to the selector lever position **D/S**. This also applies when in the tiptronic shift gate ⇒ *Shifting using tiptronic*.

Selector lever lock

The selector lever lock prevents you from selecting a gear accidentally when in the **P** or **N** position, causing the vehicle to roll.

To release the selector lever lock, switch the ignition on and press the brake pedal. Then press the lock button on the selector lever handle in the direction of the arrow *fig. 99*.

When skipping past the **N** position, for example by switching from reverse gear to **D/S**, the selector lever is not locked. This makes it possible to free the vehicle when it is stuck by “rocking” it. If the lever remains in the **N** position for more than approx. 1 second when the vehicle is traveling at a speed lower than approx. 5 km/h (approx. 3 mph) and the brake pedal has not been pressed, the selector lever lock will engage ⇒ ⚠.

⚠ WARNING

Engaging the incorrect gear can cause you to lose control of the vehicle, which could lead to accidents and serious injuries.

- Never press the accelerator pedal when engaging a gear.
- If you release the brake pedal while the engine is running and a gear is engaged, the vehicle will start moving.
- Never shift to reverse gear **R** while driving or engage the **P** parking lock while driving.

⚠ WARNING

Unintentional vehicle movements can cause serious injuries.

- As the driver, never leave the driver seat when the engine is running and a gear is engaged. If you have to leave the vehicle while the engine is running, always set the electronic parking brake and move the selector lever to the **P** position.
- When the engine is running and the **D/S** or **R** gear is engaged, hold the vehicle with the brake pedal. Even at idle speed, power is still being transmitted and the vehicle will “creep”.
- Never shift into reverse gear **R** or engage the parking lock **P** while the vehicle is moving.
- Never leave the vehicle in selector lever position **N**. The vehicle will roll downhill regardless of whether the engine is running or not.

ⓘ NOTICE

If the electronic parking brake is not switched on while the vehicle is stationary and the brake pedal is released while the parking lock **P** is engaged, the vehicle may move forward or backward a few centimeters.

ⓘ If **N** is engaged by mistake while driving, take your foot off the accelerator pedal. Wait until the engine is at idle speed in neutral before shifting into a drive gear.

ⓘ If the selector lever is left for a long period of time in any position other than in the parking lock **P** when the engine is switched off, the 12 V vehicle battery will drain.

Shifting using tiptronic

The tiptronic mode allows you to shift gears manually on an automatic transmission.

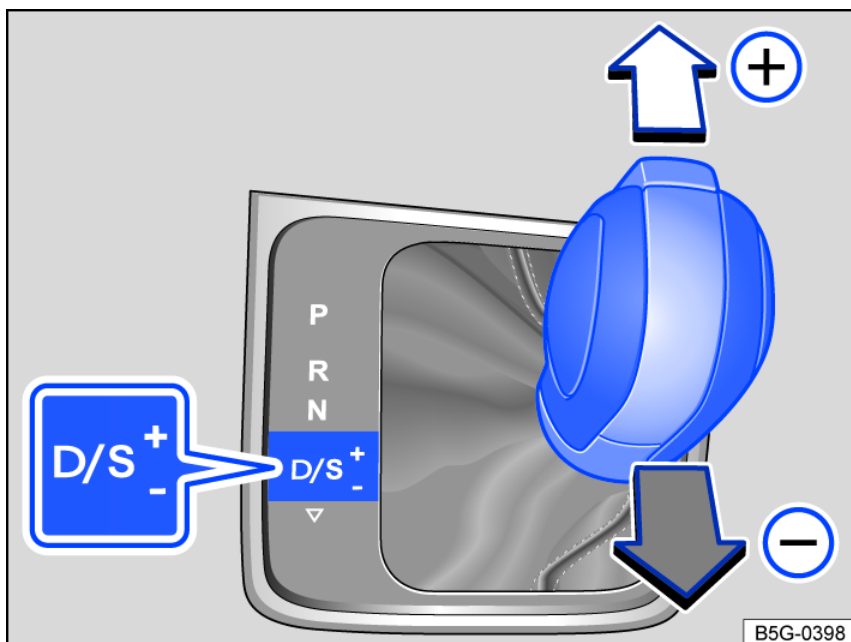

Fig. 100 Selector lever in tiptronic position (left-hand drive vehicle). The right-hand drive vehicle is a mirror image.



Fig. 101 Steering wheel with shift paddles for Tiptronic.

When shifting in the tiptronic program, the gear currently engaged is maintained. This applies until the system shifts gears automatically due to the current driving situation.

Using tiptronic with the selector lever

1. Press the selector lever from the selector lever position **D/S** to the right to the tiptronic position.
2. Tap the selector lever forward **+** or to the rear **-** to upshift or downshift *fig. 100*.

The lock button on the selector lever must not be pressed when tapping the selector lever within the tiptronic shift gate.

Operating Tiptronic with the shift paddles

1. Pull the right shift paddle toward the steering wheel to shift up *fig. 101*.
2. Pull the left shift paddle toward the steering wheel to shift down.
3. Pull the right shift paddle toward the steering wheel for about a second to leave the tiptronic program.

The Tiptronic program ends automatically if you do not operate the shift paddles for some time and the selector lever is not in the Tiptronic gate.

! NOTICE

When accelerating, the transmission automatically upshifts to the next gear shortly before the maximum permissible engine RPM is reached.

! NOTICE

When downshifting manually, the transmission only shifts if it is no longer possible to over-rev the engine.

Driving with an automatic transmission

The transmission shifts up and down automatically when in the forward driving gears.

Driving on an incline

The steeper the incline, the lower the gear that you should select. Lower gears increase the engine braking effect. Never let the vehicle roll down mountains or hills in the **N** neutral setting.

1. Reduce your speed.
2. Push the selector lever to the right out of the **D/S** selector lever position and into the tiptronic shift gate.
3. Tap the selector lever back to downshift.

Or: Downshift using the shift paddles on the steering wheel.

Stopping and starting to drive uphill

The steeper the hill, the lower the gear that you should select.

Auto Hold should be used when stopping or starting uphill when the engine is running.

If you stop on a hill with a gear selected, always press the brake pedal or set the electronic parking brake to prevent the vehicle from rolling away. Only release the brake pedal or the electronic parking brake once you start driving ⇒ .

Coasting with a DSG® automated transmission

When coasting, the vehicle's momentum is used to save fuel with predictive driving. The engine does not slow down the vehicle, so it can roll for a longer period. The function is only available in selector lever position **D/S** and within a speed range of approx. 40 to 130 km/h (approx. 25 to 80 mph).

If the brake is engaged while rolling, the engine remains switched off until the vehicle comes to a complete stop.

When rolling without braking, the engine starts again automatically when the vehicle reaches "creeping pace".

The engine may restart automatically to ensure the engine restarts safely and there is a secure supply of electricity to the vehicle electrical system.

Triggering the coasting feature

1. In the driving mode selection, select the Eco driving mode.
2. Take your foot off the accelerator. The engine is disengaged and in neutral. The vehicle is rolling without any engine braking effect.

Interrupting coasting

1. Press the brake pedal firmly.

Or: Press the accelerator pedal or brake pedal briefly.

Or: Pull a shift paddle towards the steering wheel.

Or: Push the selector lever into the tiptronic position.

Or: Change driving modes from Eco.

Kick-down

The kick-down function makes maximum acceleration possible in selector lever position **D/S** or in the tiptronic position.

When you press the accelerator pedal all the way down, the automatic transmission downshifts into a lower gear, depending on the vehicle speed and engine RPM. This utilizes the full acceleration power of the vehicle ⇒ .

With kick-down, the automatic upshift to the next gear only occurs if the maximum predefined engine RPM is reached.

For vehicles with driving mode selection, if the Eco driving mode is selected and the accelerator pedal is fully depressed past the pressure point, the engine power is controlled automatically so that the vehicle achieves maximum acceleration.

Launch Control Program

Depending on the vehicle equipment, vehicles with automatic transmission have a Launch Control Program. The Launch Control Program provides maximum acceleration from a standstill.

1. Switch off ASR.
2. Use your left foot to press down on the brake pedal and hold it.
3. Move the selector lever to selector lever position **D/S** in gear **S** or to the tiptronic position.
Or: on vehicles with Driving Mode Selection, select the Sport or Race driving mode.
4. Use your right foot to press down on the accelerator pedal until an engine speed of approx. 3200 rpm is reached.
5. Take your left foot off the brake ⇒ . The vehicle starts with maximum acceleration.
6. Switch ASR back on after acceleration!

WARNING

Fast acceleration can cause traction loss and sliding, especially on slippery roads. This could cause loss in vehicle control, accidents, and serious injuries.

- Always adapt your driving style to the flow of traffic.
- Only use the kick-down function or accelerate quickly when the visibility, weather, road, and traffic conditions allow it, and when other road users will not be endangered by the vehicle's acceleration and driving style.

- Please note that the drive wheels can continue to spin and the vehicle can slide if the traction control system is switched off, especially if the road is slippery.
- Switch the traction control system back on after the acceleration.
- Only use the Launch Control Program when road and traffic conditions permit it.

⚠ WARNING

Never let the brakes “rub” too often and too long or press the brake pedal too often and too long. Prolonged braking causes the brakes to overheat. This can considerably reduce braking performance, considerably increase braking distance and possibly lead to a total brake system malfunction.

ⓘ NOTICE

- If you stop on inclines when a gear is engaged, do not press the accelerator pedal to prevent the vehicle from rolling away. This can cause the automatic transmission to overheat and can damage it.
- Never let the vehicle roll in the **N** selector lever position, especially when the engine is stopped. The automatic transmission is not lubricated and this can damage it.
- Vehicles with the Launch Control Program: All vehicle components are put under intense strain when accelerating with the Launch Control Program. This can cause increased wear.

ⓘ NOTICE

Never let the brakes “rub” by pressing the pedal lightly when braking is not really necessary. This increases wear.

Troubleshooting

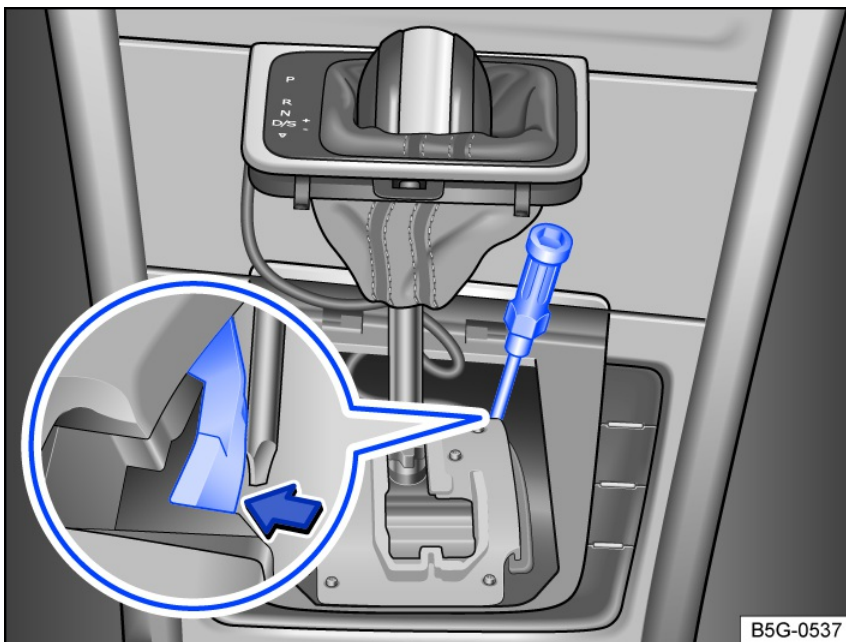

Fig. 102 Manually release the Automatic Shift Lock (ASL) (variant 1).

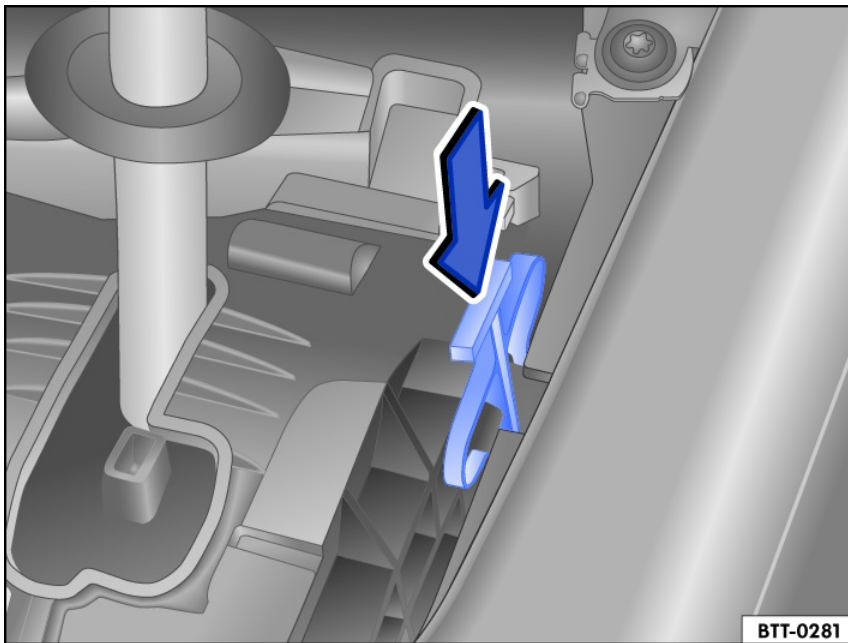

Fig. 103 Manually release the Automatic Shift Lock (ASL) (variant 2).

 **The engine is not starting**

The green indicator light turns on.

The brake pedal was not pressed, for example when trying to shift to another gear using the selector lever.

1. Press the brake pedal to select a gear.

 **Driving is restricted by the lock button**

The green indicator light blinks.

The lock button in the selector lever is not engaged.

1. Check if the lock button is locked.
2. Lock the lock button into place if necessary.

 **Driving is restricted by the selector lever lock**

The green indicator light blinks. A message is additionally displayed.

In rare cases, the Automatic Shift Lock (ASL) may not lock in vehicles with a DSG[®] automated transmission.

The engine will then be disabled to prevent the vehicle from going into motion unintentionally.

1. Press and release the brake pedal again.

 **Transmission overheating**

The yellow indicator light turns on.

An audible warning may also sound. Where applicable, a message will appear in the instrument cluster display.

The DSG[®] automated transmission can become too hot, for example due to frequently starting up on slopes.

1. At the next opportunity, stop and let the transmission cool down with the parking lock **P** engaged and the engine running ⇒ .
2. If the indicator light does not turn off, do not continue driving.
3. Contact an authorized Volkswagen dealer or authorized Volkswagen Service Facility for assistance. Otherwise, the transmission could become severely damaged.

 **Transmission overheating**

The red warning light turns on.

An audible warning may also sound. Where applicable, a message will appear in the instrument cluster display.

The DSG[®] automated transmission can become too hot, for example due to frequently starting up on slopes.

 **Do not continue driving!**

1. Let the transmission cool down with the parking lock **P** engaged and the engine running ⇒ .
2. If the warning light stays on, stop driving.
3. Contact an authorized Volkswagen dealer or authorized Volkswagen Service Facility for assistance. Otherwise, the transmission could become severely

damaged.

Selector lever lock emergency release

If there is a loss of power, for example, the 12 V vehicle battery is drained and the vehicle should be towed, then the selector lever lock must be released manually. Contact an authorized Volkswagen dealer or authorized Volkswagen Service Facility for assistance.

The emergency release is located under the shift gate cover.

Remove the cover on the shift gate:

1. Set the electronic parking brake. If you cannot set the electronic parking brake, the vehicle must be secured another way to prevent it from rolling.
2. Switch the ignition off.
3. Pull the cover near the selector lever boot upward carefully with the wires connected.
4. Fold the cover upward over the selector lever.

Depending on the equipment, there can be two different emergency releases for the Automatic Shift Lock (ASL):

Manually release the selector lever lock:

1. Using the flat blade of the screwdriver from the vehicle toolkit, carefully push the release lever in the direction of the arrow *fig. 102* (detail drawing) and hold it in this position (variant 1).
Or: press the release lever in the direction of the arrow *fig. 103* and hold it in this position (variant 2).
2. Press the lock button forward into the selector lever handle and move the selector lever to the **N** position.
3. After releasing the cover manually, carefully press into the center console while making sure the wires are in the correct position.

⚠ WARNING

Never release the parking lock **P** once the electronic parking brake is switched off. Otherwise, the vehicle may start to move unexpectedly on inclines or hills, which could then lead to accidents and serious injuries.

Emergency program

If all of the selector lever position displays have a gray background on the instrument cluster display, this means there is a system malfunction. The DSG® automated transmission runs in emergency mode. The vehicle can still be driven in emergency mode, but only at a reduced speed and not in all gears.

With the DSG® automated transmission, it may no longer be possible to drive in reverse gear in some cases.

In all cases, have the DSG® automated transmission checked immediately by suitably qualified professionals. Volkswagen recommends contacting an authorized Volkswagen dealer or authorized Volkswagen Service Facility.

Vehicle is not moving even when a drive gear is engaged

If the vehicle does not move in the desired direction, the system may not have engaged the drive position correctly.

1. Press the brake pedal and select the drive position again.
2. If the vehicle still does not move in the desired direction, there is a system malfunction. See an authorized Volkswagen dealer or authorized Volkswagen Service Facility for assistance to have the system checked.

ⓘ NOTICE

If you allow the vehicle to roll for a long period of time or at high speed with the engine off and the selector lever in the **N** position, the DSG® automated transmission will be damaged, e.g. in the case of towing.

ⓘ NOTICE

- Immediately stop the vehicle safely or drive faster than approx. 20 km/h (approx. 12 mph) the first time the vehicle indicates that the transmission is overheating.
- Stop the vehicle safely and switch off the engine as soon as possible if the message and audible warning are repeating approximately every 10 seconds. Let the transmission cool down.
- Only continue driving when the audible warning stops to reduce the risk of damaging the transmission. As long as the transmission is overheated, avoid starting the vehicle and driving slowly, like at walking speeds.

Driving on slopes

Hill start assist

Hill start assist helps when starting to drive uphill by actively holding the

vehicle in place.

Functional requirements

The following requirements must be met at the same time:

- The vehicle must be stationary and held with the brake pedal until you start driving.
- The engine must be running “evenly”.
- A gear or a position is engaged for driving uphill.

To start driving, take your foot off the brake pedal and press the accelerator pedal immediately. The brakes will release gradually as you start driving.

 **The holding function of the Hill Start Assist remains active only for a short time. Drive off within approx. two seconds.**

When is it active?

Hill Start Assist is immediately deactivated if one of the conditions specified below is no longer met:

- The driver's door is opened.
- If the engine is running “unevenly” or in the event of an engine fault.
- The engine is switched off or it stalls.
- The selector lever is in the neutral position **N**.

CAUTION

If you do not pull away immediately after releasing the brake pedal, the vehicle may roll backward under certain circumstances.

- If this is the case, press the brake pedal or set the electronic parking brake immediately.
- Press the brake pedal for a few seconds before you start to drive if you are driving on an incline in heavy traffic and you would like to prevent the vehicle from rolling backwards when starting to drive.

Downhill speed control

Downhill speed control helps the driver when traveling on slopes.

System function

The DSG® automated transmission selects the optimum gear itself, depending on the present gradient and current speed. The selector lever must be in the **D/S** selector lever position. Downhill speed control is not active in Tiptronic mode.

As the downhill speed control can only downshift as far as third gear, you may need to switch to Tiptronic mode on very steep downhill stretches. In Tiptronic mode, manually shift into second or first gear to use the engine's braking efficiency and reduce the load on the brakes.

While downhill speed control is active, the start-stop system is automatically deactivated.

Automatically activating downhill speed control

- If the gradient is greater than approximately 6%.
- **And:** if the selector lever is in the **D/S** selector lever position.
- In addition, if the cruise control system (CCS) is switched off: if the speed is slower than approx. 80 km/h (approx. 50 mph).
Or: The brake is pressed.
- Additionally if the cruise control system is active: If the saved speed is exceeded.
- In addition, if Adaptive Cruise Control (AAC) is switched off: if the speed is slower than approx. 80 km/h (approx. 50 mph).
Or: The brake is pressed.
- Additionally if Adaptive Cruise Control (ACC) is active: If the saved speed is exceeded.

Downhill speed control deactivates automatically

- When the gradient decreases.
- If the transmission upshifts because the engine speed is greater than approximately 4500 rpm.
- Additionally if the cruise control system is active: if the saved speed can be maintained.
- Additionally if Adaptive Cruise Control (ACC) is active: if the saved speed can be maintained.

WARNING

The intelligent technology of downhill speed control cannot overcome the natural laws of physics and it can only operate within the limits of the system. Do not allow the increased convenience of the downhill speed control to tempt you into taking risks.

- Unintentional vehicle movements can cause serious injuries.
- Downhill speed control is not a replacement for the driver's attention.
- Always adapt your speed and driving style to the visibility, weather, road and traffic conditions.
- Downhill speed control cannot hold the vehicle on the incline or brake sufficiently going downhill in every situation, for example if the ground is slippery or icy.

WARNING

Always be ready to brake. If this is not the case, accidents and injuries may result.

- Downhill speed control is merely a tool and cannot sufficiently brake the vehicle going downhill under every circumstance.
- The vehicle can go faster despite the downhill speed control.

Steering

Steering information

To make it more difficult to steal the vehicle, the steering must always be locked before leaving the vehicle.

Steering

Power steering on an electromechanical steering system adjusts automatically based on the driving speed, the steering torque, and the steering angle of the wheels. Electromechanical power steering works only when the engine is running. The steering also works if the start-stop system engages and the engine switches off.

If the power steering system is impaired or malfunctioning, a significantly greater amount of force than normal must be used to steer.

On vehicles with Driving Mode Selection, power steering handling can be influenced by the selected driving mode.

Electronic steering column lock

1. Stop the vehicle.
2. Depending on the vehicle equipment: Engage the parking lock **P**.
3. Switch the ignition off and then open the driver's door.

The steering column will be locked.

If the steering column does not lock, first open the driver's door and then switch the ignition off. As long as the vehicle is unlocked, the steering column also stays unlocked.

Countersteering assist

The countersteering assist provides the driver with steering assistance in critical driving situations. Additional steering power supports the driver when countersteering ⇒ .

Progressive steering

Depending on the vehicle's equipment, the progressive steering can adapt the force of the steering movement to the driving situation. Progressive steering only works when the engine is running.

In city traffic, less steering movement is needed for parking, maneuvering or for taking sharp bends.

On highways or on expressways, progressive steering gives a sportier, direct steering experience and noticeable dynamics when driving along curved stretches, for instance.

WARNING

If the power steering is not functioning, the steering wheel becomes stiff, making it much more difficult to steer. This can result in loss of control of the vehicle, accidents, serious injuries or death.

- Power steering works only when the engine is running.
- Never let the vehicle roll when the engine is stopped.
- Never switch off the ignition when the vehicle is in motion. The steering column lock could engage and you would not be able to steer the vehicle.

WARNING

The counter-steering assistance and the ESC help the driver steer the vehicle in critical driving situations. The driver must always steer the vehicle in every scenario. The vehicle is not steered by the countersteering assist.

When the vehicle is being towed, switch on the ignition so that the turn signals, horn, windshield wipers, and the windshield washer system can be activated.

Troubleshooting

Steering malfunction

The red warning light turns on or flashes.

There is an electromechanical steering or electronic steering column lock malfunction.

Do not continue driving!

1. Contact an authorized Volkswagen dealer or authorized Volkswagen Service Facility for assistance.
 - If the red warning light turns on, it may be difficult to move the steering wheel because the electromechanical steering system is malfunctioning.
 - If the red warning light blinks, the steering column cannot unlock.

Steering malfunction

The yellow indicator light turns on or flashes.

The steering is stiffer or more sensitive than usual.

The indicator light comes on permanently:

1. Restart the engine and drive the vehicle slowly for a short distance.
2. If the indicator light stays on, contact a suitably qualified professional and have the system checked. Volkswagen recommends contacting an authorized Volkswagen dealer or authorized Volkswagen Service Facility.

The indicator light blinks:

1. Turn the steering wheel back and forth slightly.
2. Switch the ignition off and back on.
3. Pay attention to the messages in the instrument cluster display.
4. If the indicator light continues to flash after switching the ignition back on, do not continue driving. Contact an authorized Volkswagen dealer or authorized Volkswagen Service Facility for assistance.

Driving Mode Selection

Introduction

Via the driving modes, the driver can adapt various properties of vehicle systems to the current driving situation, the desired driving comfort, and for an economic driving style. The suspension, steering, drive, and the air conditioner are some of the vehicle systems that can be adjusted.

Different driving modes are available depending on the vehicle equipment. The influence of vehicle systems on the individual driving modes depends on the vehicle equipment.

Vehicles with adaptive chassis control (DCC)

During the drive, the adaptive chassis control (DCC) adapts the suspension damping to the current ground and driving situation. The adaptive chassis control also incorporates the suspension tuning of the selected driving mode.

Selecting the driving mode



Fig. 104 In the center armrest: Driving Mode Selection **MODE** button.

The driving mode can be selected when the ignition is switched on and the vehicle is stationary or while driving.

WARNING



Selecting the driving mode while driving can distract you from traffic and increase the risk of accidents.

- Always drive attentively and responsibly.

If you select a driving mode while driving, the vehicle systems, except for Drive, will be switched over to the new driving mode immediately.

1. When the traffic situation allows it, briefly take your foot off the accelerator pedal to enable the newly selected driving mode to be applied to the Drive vehicle system as well.

Selecting a driving mode via the MODE button

1. Press  *fig. 104*.
2. To select driving modes, press  again or tap the desired driving mode in the Infotainment system.

If the Normal driving mode is selected, the LEDs in the MODE button will remain switched off, depending on the version.



Displaying information about the driving mode

1. To display additional information about the selected driving mode, tap  in the Infotainment system.



Selecting the Custom driving mode

1. Press .
2. Select Custom in the Infotainment system.
3. To open the Individual menu, tap Adjust.

Driving mode properties

 The Eco driving mode switches the vehicle to fuel-efficient operation and supports the driver with an fuel-saving driving style. The transmission automatically shifts to E in the Eco driving mode.  The Comfort driving mode provides a comfort-oriented vehicle setup and is suited for long trips, for example.

The Comfort driving mode is only available in vehicles with DCC.

 The Normal driving mode shows the basic settings of the vehicle systems and offers a balanced calibration, for example for everyday use.  The Sport driving mode gives the driver a sporty feel. If the Sport driving mode is selected, vehicles with an automatic transmission switch to S.  With the Custom driving mode, you can adapt individual vehicle systems according to your preferences.

Standard behavior of the driving mode and the vehicle systems

The Normal driving mode represents the basic settings for the vehicle systems when the ignition is switched on.

Behavior of the driving mode when switching the ignition off and on

If you switch the ignition off and then on again, the previously selected driving mode remains selected.

Behavior of the Drive vehicle system when the ignition is switched off and on

The settings for the Drive vehicle system are reset to the Normal driving mode settings when you switch the ignition off and on again.

The other vehicle systems will retain their settings.

You can change the Drive vehicle system back to the preferred driving mode.

1. Select your desired driving mode again.

Troubleshooting

Adaptive chassis control malfunction

The yellow indicator light turns on.

The message Fault: Damper control may appear in the instrument cluster display.

1. Contact an authorized Volkswagen dealer or authorized Volkswagen Service Facility to have the system inspected. Volkswagen recommends contacting an authorized Volkswagen dealer or authorized Volkswagen Service Facility.

The driving mode or the vehicle systems do not behave as expected

1. Pay attention to the standard behavior of the driving mode and the vehicle systems ⇒ *Standard behavior of the driving mode and the vehicle systems*.

Driver assistance systems

Cruise control system

Introduction

The cruise control system helps to maintain a set speed.

Speed range

The cruise control system is available at speeds above approximately 20 km/h (approximately 15 mph) when driving forward.

Driving with the Cruise Control System

You can override the stored speed at any time, for example, to pass another vehicle. The regulation function is paused while the vehicle accelerates and then resumes the stored speed.

Displays

If the cruise control system is switched on, the instrument cluster display indicates the saved speed and the status of the cruise control system.

The following indicator lights may turn on depending on the driving situation and the instrument cluster version:

Cruise control system is switched on, speed regulation active.

If the cruise control system is not regulating the speed, the indicator lights are small or grey.

If no speed is stored, the instrument cluster display shows --- instead of the speed.

Driving downhill

The vehicle cannot maintain the saved speed in all driving situations. Always be ready to apply the brakes.

1. Downshift before traveling downhill for extended periods.

This will enable you to utilize the engine braking effect and reduce the load on the brakes.

WARNING

If it is not possible to drive safely with enough distance and a constant speed, using the cruise control system may cause accidents and serious injuries. Using the cruise control system does not relieve the driver from their responsibility for their vehicle's speed.

- Always adapt your speed and remain a safe distance to vehicles driving ahead according to the visual, weather, road, and traffic conditions.
- Never use the cruise control system when visibility is poor, when there is not enough distance, or when roads are steep, winding, flooded, or slippery, for example from snow, ice, moisture, or gravel.
- Never use the cruise control system when driving off-road or on unpaved roads.

Operating the cruise control system

 Please read the introductory information and heed the Warnings and Notice  [Introduction](#).



Fig. 105 Left side of the multi-function steering wheel (variant 1).



Fig. 106 Left side of the multi-function steering wheel (variant 2).

Switching on

1. Press the  button.

No speed is saved. At this stage, the limiter will not yet start regulating your speed.

Starting the regulation function

1. Press the **SET** button while driving.

The cruise control system saves and controls the current speed.

Setting the speed

You can adjust the saved speed as follows:

- + 1 mph (1 km/h):** Press the  button.

Steering wheel version 2: Alternatively, swipe the button from the bottom to the top.

- 1 mph (1 km/h):** Press the  button.

Steering wheel version 2: Alternatively, swipe the button from the top to the bottom.

To change the stored speed continuously, press and hold the respective button.

The vehicle adjusts to the current speed by accelerating or decelerating. The vehicle does not brake actively.

Canceling the regulation function

1. Press the **CNCL** or  button briefly.

Or: Press the brake pedal.

The vehicle speed remains stored in the system.

Resuming the regulation function

1. Press the **RES** button.

The cruise control system resumes and maintains the saved speed.

WARNING

There is the risk of an accident if you inadvertently resume at the saved speed or if the saved speed is too fast for the current road, traffic, or weather conditions. This may result in serious injury or even death.

- Check whether the saved speed is suitable for the current road, traffic, or weather conditions before you resume the cruise control system.
- Switch off the cruise control system if you do not require it.

Switching off

1. Press and hold the  button.

The cruise control system is switched off and the saved speed is deleted.

Troubleshooting

 Please read the introductory information and heed the Warnings and Notice ⇒  **Introduction.**

Cruise control system malfunction

Malfunction. The yellow indicator light turns on.

1. Switch off the cruise control system and seek assistance from an authorized Volkswagen dealer or authorized Volkswagen Service Facility. Volkswagen recommends contacting an authorized Volkswagen dealer or authorized Volkswagen Service Facility.

The regulation function is canceled automatically

- The vehicle has exceeded the stored speed for an extended period.
- No gear is engaged for driving forward.
- Brake assistance systems, for example ASR or ESC, are active.
- The vehicle has been braked by Front Assist.
- If the problem persists, switch off the cruise control system and seek assistance from an authorized Volkswagen dealer or authorized Volkswagen Service Facility. Volkswagen recommends contacting an authorized Volkswagen dealer or authorized Volkswagen Service Facility.

Adaptive Cruise Control (ACC)

Introduction

Adaptive Cruise Control (ACC) maintains your selected speed. When the vehicle approaches a vehicle driving ahead, the ACC adjusts the speed automatically and maintains your set distance to the vehicle driving ahead.

Does this vehicle have ACC?

The vehicle has ACC if you can adjust ACC settings in the Assistance systems menu in the Infotainment system.

Speed range

You can set a speed between approx. 20 mph (approx. 30 km/h) and approx. 130 mph (approx. 210 km/h). The maximum speed that you can set may be lower, depending on the vehicle equipment and country.

Driving with ACC

You can override the ACC system at any time. The regulation function is canceled when you apply the brakes. When you accelerate, the regulation function is paused while accelerating and then resumed.

If a trailer is hitched, ACC is less dynamic.

Driver intervention request

 **If automatic deceleration by the ACC is not sufficient or the system limits are reached, the ACC will prompt you – with a message in the instrument cluster – to also apply the brakes. The red warning light will also turn on and a warning tone will sound. Take over steering and be ready to brake.**

Radar sensor

ACC detects driving situations using a radar sensor in the front of the vehicle. The radar sensor has a range of up to approx. 120 m (approx. 400 ft).

WARNING

The intelligent technology of the ACC cannot overcome the natural laws of physics and can operate only within the limits of the system. Never allow the increased convenience to tempt you into taking risks. Careless or unintended use of the ACC system can cause accidents and serious injuries. The system cannot replace the driver's attention.

- Always adapt your speed and distance to vehicles driving ahead based on the visual, weather, road, and traffic conditions.
- Never use ACC when visibility is poor or when roads are steep, winding, flooded, or slippery, like from snow, ice, moisture, or gravel.
- Never use ACC when driving off-road or on unpaved roads. ACC is only designed for use on paved roads.
- Take over steering immediately if a driver intervention prompt appears in the instrument cluster display or the deceleration by ACC is not sufficient.
- Apply the brakes if the vehicle continues to roll unintentionally, e.g. after a driver intervention prompt.
- Always be ready to resume control of the vehicle speed.

Special driving situations

 **Please read the introductory information and heed the Warnings and Notice** ⇒  **Introduction.**

The functions described below depend on the vehicle equipment and are not available in all countries.

Stop-and-go traffic

ACC can brake vehicles with automatic transmissions to a stop and hold them stationary. ACC remains active, and the instrument cluster display shows ACC is ready for a few seconds. In this time, the vehicle will automatically move again once the vehicle driving ahead starts.

Extend drive-readiness or reactivate:

1. Press the **RES** button.

Driving off when drive-readiness has ended and the vehicle driving ahead has already started moving:

1. Press the **RES** button.

Or: Briefly press the accelerator pedal.

The ACC does not stay active in the following scenarios:

- The stationary phase lasts several minutes.
- A vehicle door is opened.
- The ignition is switched off.

WARNING

If ACC is ready appears in the instrument cluster display and the vehicle driving ahead starts to move, your vehicle will start driving automatically. The vehicle may not be able to detect obstacles in the vehicle's path when this happens. This may cause accidents and serious injuries.

- Check the vehicle's path every time before you start driving and brake the vehicle if necessary.

ACC limitations

 Please read the introductory information and heed the Warnings and Notice ⇒  *Introduction*.

When should I not use ACC?

The ACC system is not suitable in the following situations. Canceling the regulation function ⇒ :

- When driving in heavy rain, snow, or spray
- When driving through construction zones, tunnels or toll stations.
- When driving on winding roads, for example, mountain roads
- When driving off-road
- When driving in parking ramps
- When driving on roads with embedded metal objects, such as railroad tracks
- When driving on gravel roads
- Following a violent impact affecting components within the range of the radar sensor, e.g. following a rear-end collision.

WARNING

If you use the ACC in the situations mentioned, accidents and serious injuries may result and legal regulations may be violated.

Delayed reaction

If the radar sensor is exposed to environmental conditions that limit its function, the system may have a delayed response to this. Therefore, the display that indicates that functions are restricted may be delayed when you first start driving or while driving ⇒  *Introduction*.

Unrecognizable objects

ACC only detects vehicles that are moving in the same direction. The following will not be detected:

- Pedestrians
- Animals
- Stationary vehicles
- Vehicles crossing the street or oncoming vehicles
- Other stationary obstacles

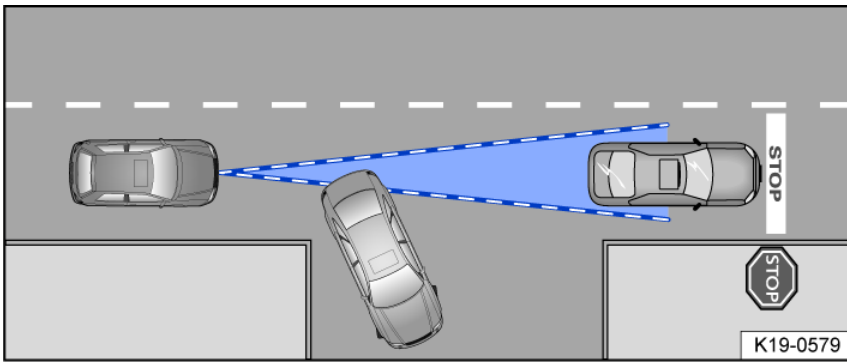

Fig. 107 Turning and stationary vehicles.

If, for example, a vehicle detected by the ACC turns or changes lanes and there is a stationary vehicle in front of this vehicle, the ACC will not react to the stationary vehicle [fig. 107](#).

Curves

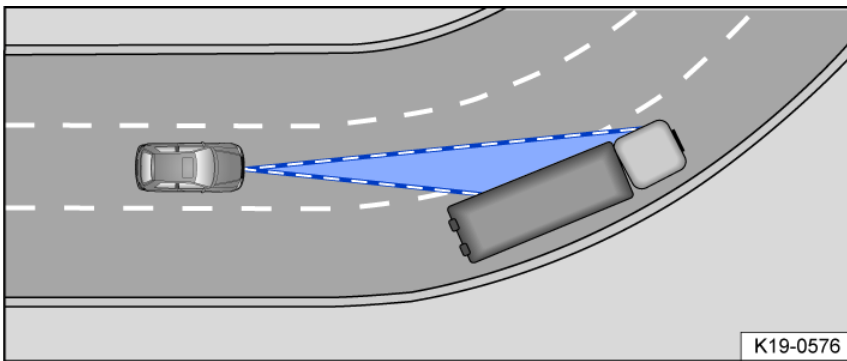

Fig. 108 Driving around curves.

The radar sensor only measures straight ahead. Therefore, on tight curves, vehicles may be detected by mistake or vehicles driving ahead may not be detected [fig. 108](#).

Vehicles outside the sensor range

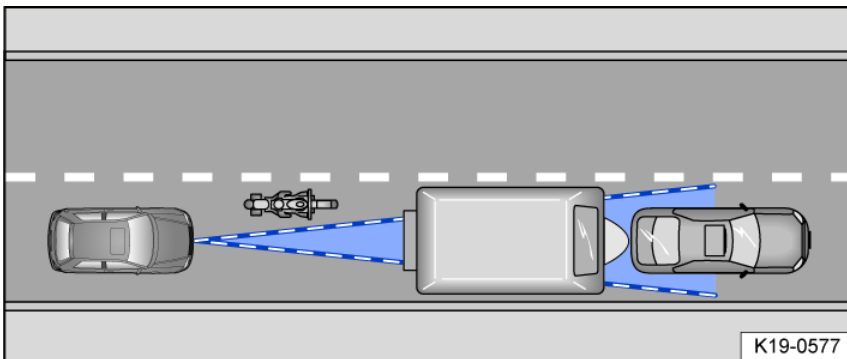

Fig. 109 Narrow vehicle.

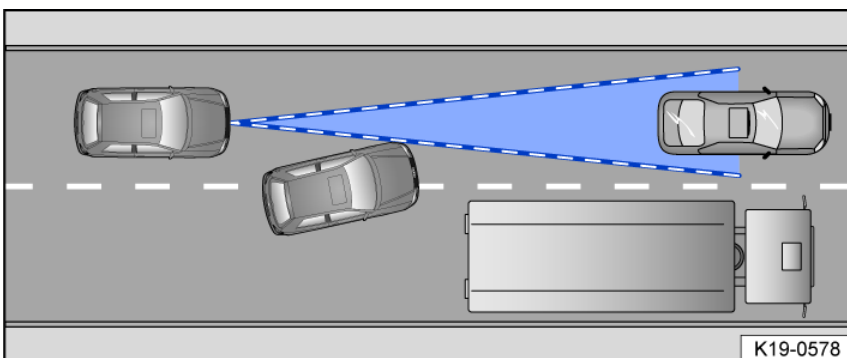

Fig. 110 Changing lanes.

The ACC may not react, may react with a delay, or may react in a way that is not desired in the following situations:

- If there are vehicles that are driving close to your vehicle but outside the sensor range, such as motorcycles [fig. 109](#).
- If vehicles change to your lane close in front of your vehicle [fig. 110](#).
- Vehicles with attachments exceeding the vehicle dimensions.

Switching ACC on and off

📖 Please read the introductory information and heed the Warnings and Notice ⇒ ⚠️ *Introduction.*



Fig. 111 Left side of the multi-function steering wheel (variant 1).



Fig. 112 Left side of the multi-function steering wheel (variant 2).

Switching on

1. Press the  button.
ACC is not yet functioning.

Starting the regulation function

1. Press the **SET** button while driving forward.

ACC saves the current speed and maintains the set distance. If the current speed is outside the specified speed range, the ACC adjusts the minimum speed when driving too slowly or the maximum speed when driving too quickly.

In addition, the anti-slip regulation (ASR) is activated and ESC Sport is deactivated.

The following indicator lights may turn on depending on the driving situation:

 ACC is regulating – no vehicle ahead detected.  ACC is regulating – vehicle ahead detected.

If the ACC is not functioning, the gray indicator lights come on.

Canceling the regulation function

1. Press the  button briefly.

Or: Press the brake pedal.

If the respective indicator light for the driving situation lights up gray, the speed and distance are saved.

If the anti-slip regulation (ASR) is deactivated, then the Adaptive Cruise Control is automatically stopped.

Resuming the regulation function

1. Press the **(RES)** button.

ACC assumes the last set speed and the last set distance. The instrument cluster display shows the set speed, and indicator lights turn on corresponding to the driving situation.

Switching off

1. Press and hold the **(OFF)** button.

The set speed is deleted.

Adjusting the ACC settings

📖 Please read the introductory information and heed the Warnings and Notice ⇒ **Introduction**.

Setting the distance

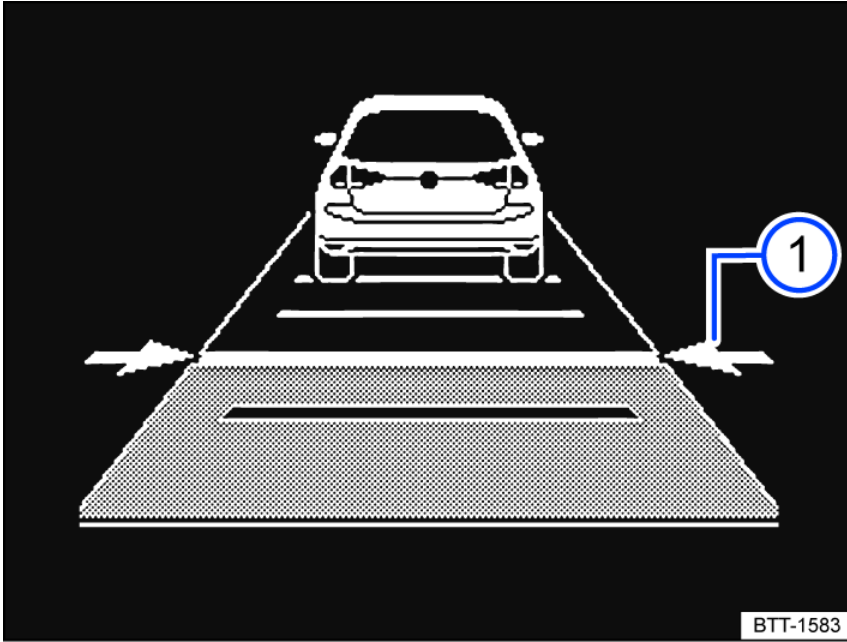

Fig. 113 In the instrument cluster display: set distance ① (general example, ACC is regulating).

You can set the distance at five levels from very short to very long:

1. Press the **(SET)** button.
2. Press the **(+)** or **(-)** button.

Steering wheel version 2: Alternatively, swipe vertically over the button area from **(SET)** to **(+)** or **(-)**.

Or: Press the **(SET)** button repeatedly until the preferred distance is set.

The instrument cluster display shows the selected level **fig. 113 ①**. Heed the country-specific regulations for minimum distance.

In the Assistance systems menu of the Infotainment system, you can choose whether you want the regulation to start at the distance that was set at the end of the journey or start at a preselected distance.

If ACC is not regulating, the set distance and the vehicle will not be highlighted on the instrument cluster display.

Setting the speed

You can adjust the stored speed within the specified speed range using the buttons on the multi-function steering wheel as follows:

+ 1 mph (1 km/h): Press the **(+)** button.

Steering wheel version 2: Alternatively, swipe the button from the bottom to the top.

- 1 mph (1 km/h): Press the **(-)** button.

Steering wheel version 2: Alternatively, swipe the button from the top to the bottom.

+ 5 mph (10 km/h): Press and hold the **(+)** button. Pressing for the first time changes to the next-largest tens digit (km/h) or fives digit (mph).

- 5 mph (10 km/h): Press and hold the **(-)** button. Pressing for the first time changes to the next-smallest tens digit (km/h) or fives digit (mph).

⚠ WARNING

If the vehicle is less than the minimum distance from the vehicle ahead and the difference in speed between the vehicle ahead and your own vehicle is so great that the speed deceleration from the ACC is not sufficient, there is a risk of a rear end collision. The braking distance also increases during rainfall and winter

road conditions.

- ACC may not be able to detect all driving situations correctly.
- Always be ready to apply the brakes yourself.
- If you press the accelerator pedal, you will override the speed and distance control. In this case, ACC will not brake automatically.
- Heed the country-specific regulations regarding minimum distance.
- Always set a longer distance when there is rain, snow, or poor visibility.

Adjusting the regulation function system settings

You can influence how the ACC reacts in a sporty driving style:

- Vehicles with Driving Mode Selection:
Select the desired driving mode.
- Vehicles without Driving Mode Selection:
Select the desired driving mode in the Assistance systems menu in the Infotainment system.

Deactivating distance control

1. Press the  button.
2. Select Control system in the instrument cluster display.
Distance control is deactivated. The vehicle only maintains the set speed.

Troubleshooting

 Please read the introductory information and heed the Warnings and Notice ⇒  [Introduction](#).

ACC is not available

The yellow indicator light turns on.

- The radar sensor is dirty. Clean the radar sensor ⇒ [Vehicle care](#).
- The visibility of the radar sensor is limited due to weather conditions, such as snow, or from soap residue or coatings. Clean the radar sensor ⇒ [Vehicle care](#)
- Radar sensor visibility is limited by attachments, decorative frames on license plate holders, or stickers. Clear the area around the radar sensor.
- The radar sensor is misaligned or damaged, for example as a result of damage to the front of the vehicle. Check if there is noticeable damage ⇒ [Repairs and technical modifications](#).
- Malfunction or fault. Stop the engine and restart.
- Painting work was carried out on or structural modifications were made to the front of the vehicle.
- The original Volkswagen emblem is not used. Volkswagen recommends the use of Volkswagen original parts or Volkswagen original accessories, which you can acquire from an authorized Volkswagen dealer or authorized Volkswagen Service Facility.
- If the problem persists, contact an authorized Volkswagen dealer or authorized Volkswagen Service Facility. Volkswagen recommends contacting an authorized Volkswagen dealer or authorized Volkswagen Service Facility.

ACC is not functioning as expected

- The radar sensor is dirty. Clean the radar sensor ⇒ [Vehicle care](#).
- The system limitations are not adhered to ⇒ [ACC limitations](#).
- The brakes are overheating, and the regulation function has been automatically canceled. Let the brakes cool down and check the function again.
- If the problem persists, contact an authorized Volkswagen dealer or authorized Volkswagen Service Facility. Volkswagen recommends contacting an authorized Volkswagen dealer or authorized Volkswagen Service Facility.

The Adaptive Cruise Control cannot start

Make sure the following requirements are met:

- Vehicles with an automatic transmission: A gear is engaged for driving forward.
- The brake lights on the vehicle are functioning.
- The brake lights on the electronically connected trailer are functioning.
- ESC is not regulating.
- The brake pedal is not being pressed.

Unusual noises during automatic braking

This is normal and not a cause for concern.

Front Assist

Introduction

Front Assist can recognize impending forward collisions and warn the driver. In addition, the system can provide support when braking and initiate an automatic braking maneuver.

The Front Assist system can help to avoid accidents but cannot replace the driver's attention.

Front Assist works solely within the system limitations. Warning times vary depending on the Traffic Situation and the driving behavior.

Range of functions

Autonomous Emergency Braking (Front Assist) includes the following extended functions, depending on the vehicle equipment and the country:

- Pedestrian Monitoring.

The functions named are (if available) automatically active if Front Assist is switched on.

Recognizable objects

Autonomous Emergency Braking (Front Assist) can recognize the following objects, depending on the vehicle equipment and the country:

- Vehicles.
- Bikes.
- Pedestrians.

Driving with Front Assist

You can cancel automatic braking interventions by moving the steering wheel or pressing the accelerator pedal.

Automatic braking

Front Assist can brake the vehicle to a stop. The vehicle will not be held at a stop after that. Press the brake pedal.

The brake pedal feels more firm during an automatic braking maneuver.

Detecting the Driving Situation

Front Assist detects driving situations using a radar sensor in the front of the vehicle. The range of the radar sensor is up to approximately 400 ft (120 m).

WARNING

The intelligent technology of Front Assist cannot overcome the natural laws of physics and it can only operate within the limits of the system. Do not allow the increased convenience provided by the Front Assist system to tempt you into taking risks. The Front Assist system cannot prevent accidents and severe injuries automatically. The driver is always responsible for control of the vehicle.

- Always adapt your speed and remain a safe distance to vehicles driving ahead according to the visual, weather, road, and traffic conditions.
- Please be aware that Autonomous Emergency Braking (Front Assist) cannot detect all objects in the speed range ⇒ *Front Assist limitations*.
- When Front Assist warns you, brake the vehicle immediately or maneuver around the obstacle, depending on the driving situation.
- Autonomous Emergency Braking (Front Assist) may intervene when not desired, e.g. when the function is limited. Therefore, consider interrupting automatic Autonomous Emergency Braking (Front Assist) interventions if necessary.
- If you are unsure which functions the vehicle has included, consult suitably qualified professionals before starting your journey. Volkswagen recommends contacting an authorized Volkswagen dealer or authorized Volkswagen Service Facility.

Warning levels and braking support

 Please read the introductory information and heed the Warnings and Notice ⇒  *Introduction*.

Speed ranges

Autonomous Emergency Braking (Front Assist) provides maximum support within these speed ranges:

- Response to vehicles: Approx. 3 mph (approx. 5 km/h) to approx. 155 mph (approx. 250 km/h).
- Response to bikes: Approx. 3 mph (approx. 5 km/h) to approx. 155 mph (approx. 250 km/h).
- Response to pedestrians: Approx. 3 mph (approx. 5 km/h) to approx. 40 mph (approx. 65 km/h).

The support system can involve an advance warning, an immediate warning, automatic braking or braking support. A distance warning may also be displayed.

Influencing factors

Whether and in which speed range Autonomous Emergency Braking (Front Assist) reacts to the named objects is dependent on the following factors:

- Type of object.

- Movement direction of the object.
- Speed of the object.
- Speed of the vehicle.

The work area can therefore be limited if the vehicle approaches an object very quickly and thus has little time to react.

Furthermore, not all warning levels are passed through in all situations. Depending on the speed, there may not be, for example, an advance warning or immediate warning, but rather an automatic braking maneuver that occurs straight away, so as to best protect the detected object.

Distance warning



Front Assist detects if there is a safety hazard from following the vehicle ahead too closely.

The indicator light turns on. Increase the distance.

Advance warning



Front Assist detects a possible collision and prepares the vehicle for possible emergency braking.

A warning tone sounds and the warning light turns on. Apply the brakes or maneuver to avoid the collision.

Immediate warning

If you do not respond to the advance warning, the brakes may be applied briefly to indicate the increasing risk of a collision. Apply the brakes or maneuver to avoid the collision.

Automatic braking

Autonomous Emergency Braking (Front Assist) can brake the vehicle automatically in several stages of increasing braking force. Reducing the vehicle speed may help to reduce the damage resulting from a collision.

Braking support

If the system detects that you are not braking enough before an impending collision, Front Assist can increase the braking force and thus help to reduce the risk of collision. The braking support is only active as long as you are firmly pressing the brake pedal.

Front Assist limitations

Please read the introductory information and heed the Warnings and Notice ⇒ [Introduction](#).

or Autonomous Emergency Braking is not available or availability is limited directly after starting the vehicle or after restarting the system. During this time, the indicator light in the instrument cluster display comes on.

Front Assist has physical and system limitations. Therefore, always pay attention and be ready to intervene as necessary.

Delayed reaction

If the radar sensor is exposed to environmental conditions that limit its function, the system may have a delayed response to this. Therefore, the display that indicates that functions are restricted may be delayed when you first start driving or while driving ⇒ [Introduction](#).

Unrecognizable objects

Autonomous Emergency Braking (Front Assist) may not react or may react with a delay to the following objects:

- If vehicles are driving close to your vehicle but outside of the sensor range, for example vehicles that are staggered around your vehicle or motorcycles
- If vehicles change to your lane close in front of your vehicle
- If vehicles have objects or accessories projecting out of the vehicle.
- If there are oncoming vehicles or vehicles crossing the street
- Stationary or oncoming pedestrians; generally no reaction to people without Pedestrian Monitoring.
- Stationary cyclists, oncoming cyclists or cyclists crossing the street.
- Pedestrians and cyclists who are not detected as such, for example because they are fully or partially hidden.

Functional limitations

Front Assist may not react, may react with a delay, or may react in a way that is not desired in the following situations:

- When driving around tight curves
- When driving in heavy rain, snow, or spray
- When driving in parking garages or tunnels.
- When driving on roads with embedded metal objects, such as railroad tracks
- When driving in reverse
- If ESC is regulating.
- If the radar sensor is dirty or obstructed
- If multiple brake lights on the vehicle are malfunctioning.
- If multiple brake lights are malfunctioning on a trailer that is connected to the vehicle electrical system

- If the vehicle is accelerating very quickly or the accelerator pedal is pressed all the way down
- In complex driving situations, such as around traffic islands
- In unclear traffic situations, for example if vehicles driving ahead are braking quickly or are turning
- If Front Assist is malfunctioning

Switching off Front Assist

Depending on the system, Front Assist may not be suitable in the following situations and must be switched off if they occur ⇒ :

- If the vehicle is not being driven on public roads, for example during off-road driving or on a racetrack.
- If the vehicle is being towed or transported
- If add-ons such as auxiliary headlights cover the radar sensor.
- If the radar sensor is malfunctioning
- Following a violent impact affecting components within the range of the radar sensor, e.g. following a rear-end collision.
- If there are multiple unwanted activations

WARNING

If you do not switch off Front Assist in these situations, accidents and serious injuries could occur.

Using Front Assist

 Please read the introductory information and heed the Warnings and Notice ⇒  [Introduction](#).

When you switch on the ignition, Front Assist and the advance warning (depending on the country) are automatically switched on.

 or  However, Front Assist is not available or its availability is restricted while the indicator light is turned on.

Volkswagen recommends always leaving Front Assist, distance warning, and advance warning switched on. For exceptions to this, see ⇒ [Front Assist limitations](#).

Switching on and off

You can switch Autonomous Emergency Braking on and off manually and view the switched on condition.

In the instrument cluster display:

1. Press the  button.
2. Switch Autonomous Emergency Braking on or off.

 Depending on the vehicle equipment, the  button is located either on the multi-function steering wheel or the turn signal and high beam lever.

In the Infotainment system:

1. Open the Assistance systems menu.
2. Switch Autonomous Emergency Braking on or off in the corresponding submenu.

 If you switch off Front Assist, the advance warning and distance warning will also be switched off. The yellow indicator light turns on in the instrument cluster display.

Adjusting the distance and advance warning setting

If Front Assist is switched on, you can set the following settings in the assistance systems menu of the Infotainment system depending on the equipment and country:

- Switch on and off distance warning.
- Switch on and off advance warning.
- Set the warning period for the advance warning.

Troubleshooting

 Please read the introductory information and heed the Warnings and Notice ⇒  [Introduction](#).

or Front Assist Starts

The indicator light lights up white or yellow depending on the country.

- Autonomous Emergency Braking (Front Assist) is temporarily not available or has limited availability. After driving straight for a short distance, Autonomous Emergency Braking is available again and the indicator light goes out. If the vehicle does not drive, the indicator light stays on.

Front Assist is not available, and the radar sensor does not have sufficient visibility

- The radar sensor is dirty. Clean the radar sensor ⇒ [Vehicle care](#).
- The visibility of the radar sensor is limited due to weather conditions, such as snow, or from soap residue or coatings. Clean the radar sensor ⇒ [Vehicle care](#)
- Radar sensor visibility is limited by attachments, decorative frames on license plate holders, or stickers. Clear the area around the radar sensor.

- The radar sensor is misaligned or damaged, for example as a result of damage to the front of the vehicle. Check if there is noticeable damage ⇒ [Repairs and technical modifications](#).
- Painting work was carried out on or structural modifications were made to the front of the vehicle.
- The original Volkswagen emblem is not used. Volkswagen recommends the use of Volkswagen original parts or Volkswagen original accessories, which you can acquire from an authorized Volkswagen dealer or authorized Volkswagen Service Facility.
- If the problem persists, turn off Autonomous Emergency Braking and contact suitably qualified professionals. Volkswagen recommends contacting an authorized Volkswagen dealer or authorized Volkswagen Service Facility.

Front Assist is not functioning as expected or has been triggered multiple times unnecessarily

- The radar sensor is dirty. Clean the radar sensor ⇒ [Vehicle care](#).
- The system limitations are not adhered to ⇒ [Front Assist limitations](#).
- If the problem persists, turn off Autonomous Emergency Braking and contact suitably qualified professionals. Volkswagen recommends contacting an authorized Volkswagen dealer or authorized Volkswagen Service Facility.

Lane Keeping System (Lane Assist)

Introduction

Lane Assist helps the driver to stay in a lane, within the system limitations. This function is not suitable for, and not designed for, autonomously keeping your vehicle in a lane.

Lane Assist detects the lane markers using a camera behind the windshield. If the system detects that the vehicle is coming too close to a lane marker, the system warns the driver with corrective steering. The driver can override the corrective steering at any time.

Speed range

Lane Assist is ready to take control (active system status) when a lane marking is detected within the system limits above approximately 35 mph (60 km/h).

WARNING

The intelligent technology of Lane Assist cannot overcome the natural laws of physics and it can only operate within the limits of the system. Careless or unintended use of Lane Assist can cause accidents and serious injuries. The system cannot replace the driver's attention and steering.

- Always adapt your speed and remain a safe distance to vehicles driving ahead according to the visual, weather, road, and traffic conditions.
- Always keep your hands on the steering wheel so that you are prepared to steer at any time. The driver is always responsible for keeping the vehicle within the lane.
- Override immediately by steering if the system intervenes when it should not.
- Pay attention to indicators in the instrument cluster display and respond to the prompts accordingly when the traffic situation allows.
- Always pay attention to the area around your vehicle and drive with anticipation.
- If the camera lens is dirty, covered, or damaged, Lane Assist may be limited.

Lane Assist limitations

 Please read the introductory information and heed the Warnings and Notice ⇒  [Introduction](#).

Lane markings not detected or not correctly recognized

Lane Assist does not correctly detect all lane markings. If lane markings are not recognized, Lane Assist may fail to intervene. Be prepared to steer at all times.

Under certain circumstances, Lane Assist may incorrectly detect poor road surfaces, road structures or objects, reflections and glare as lane markings. Override immediately if the system intervenes when it should not.

Switching off Lane Assist temporarily

In the following situations, Lane Assist may intervene when not desired or may fail to intervene when it should. Therefore, the driver's attention is especially important in these scenarios. Switch off Lane Assist temporarily:

- When the driving style is very dynamic.
- When weather or road conditions are poor
- In construction zones
- In front of bumps or dips in the road
- When not on highways or well-developed roads.

WARNING

If you do not switch off Lane Assist in these situations, accidents and serious injuries could occur.

Lane Assist is not available

The system is not available under the following conditions (inactive system status):

- The vehicle speed is less than around 55 km/h (around 30 mph).
- Lane Assist has not detected a road lane marking.
- If lanes and curves are too narrow.
- Temporarily, when the driving style is very dynamic.
- When the turn signals are switched on before a manual lane change.
- When the driver oversteers during a system intervention.
- When there is no reaction from the driver to a driver intervention prompt.

Driving with Lane Assist

📖 Please read the introductory information and heed the Warnings and Notice ⇒ ⚠️ *Introduction.*

Switching on and off

You can view the switched on condition of the Lane Assist in the instrument cluster display and in the Infotainment system. You can also switch Lane Assist on and off there.

In the instrument cluster display:

1. Press the  button.
2. Switch Lane Assist on or off.

📍 Depending on the vehicle equipment, the  button is located either on the multi-function steering wheel or the turn signal and high beam lever.

In the Infotainment system:

1. Open the Assistance systems menu.
2. Switch Lane Assist on or off in the corresponding submenu.

📍 If there is a system malfunction, Lane Assist can turn off automatically.

Displays

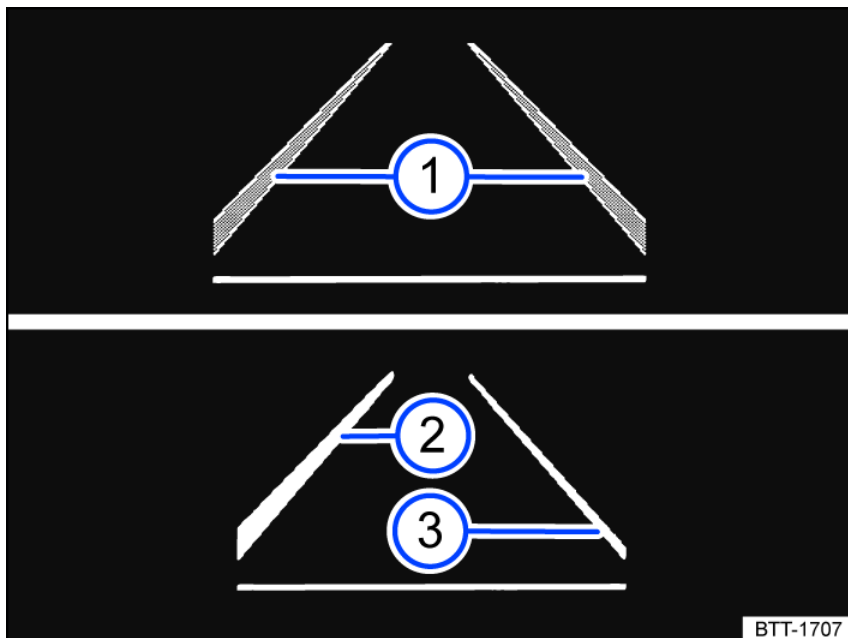



Fig. 114 In the instrument cluster display: Lane Assist indicators.

- ① Lane marking detected. The system is ready to monitor on the indicated side.
- ② Lane marking detected. The system is monitoring on the indicated side.
- ③ The system is not ready to monitor on the indicated side.

One of the following indicator lights may come on, depending on the driving situation and the instrument cluster version:

 System active and ready to control.  System in operation (corrective steering intervention).

If the indicator light does not light up, the system is not ready for operation on both sides (inactive system status) or is switched off.

 If Travel Assist is actively regulating, there will be no steering intervention and no Lane Keeping System (Lane Assist) display.

Driver intervention request

If there is no steering activity, the system prompts you to drive in the center of your lane with an indicator in the instrument cluster display and warning chimes.

If you do not respond accordingly, the system becomes inactive.

Depending on the vehicle equipment, semi-automatic vehicle control in a medical emergency (Emergency Assist) is activated.

Independently of steering activity, you are also prompted by an indicator on the instrument cluster display and by a warning chime to drive in the middle of the lane the corrective steering intervention takes a long time.

Steering wheel vibration

The following situations may cause the steering wheel to vibrate:

- A lane is no longer detected during a sharp corrective steering intervention by the system.

In addition, you can select the Vibration or Steering wheel vibration option in the Assistance systems menu in the Infotainment system. If you select this option, the steering wheel will vibrate if Lane Assist is active and you drift onto a road lane marking that the system has detected.

Troubleshooting

 Please read the introductory information and heed the Warnings and Notice ⇒  **Introduction.**

Malfunction message, Lane Assist is not available

An indicator light comes on in the instrument cluster. In addition, a message is shown in the instrument cluster display.

- The camera field of view is dirty. Clean the windshield ⇒ [Vehicle care](#).
- The camera's view is limited due to weather conditions, such as snow, or from soap residue or coatings. Clean the windshield ⇒ [Vehicle care](#).
- The camera's view is limited by attachments or stickers. Keep the area around the camera field of view clear.
- The camera is misaligned or damaged, for example as a result of damage to the windshield. Check if there is noticeable damage ⇒ [Repairs and technical modifications](#).
- The camera was automatically deactivated due to a high ambient temperature or long exposure to direct sunlight. Lane Assist will be available once the camera is available again. Stop the engine and restart.
- Malfunction or fault. Stop the engine and restart.
- If the problem persists, contact an authorized Volkswagen dealer or authorized Volkswagen Service Facility. Volkswagen recommends contacting an authorized Volkswagen dealer or authorized Volkswagen Service Facility.

 It can take a few seconds once the ignition has been switched on for a system fault to be recognized.

 If Lane Assist is not available, Emergency Assist is not available either.

 If Lane Assist is not available, Travel Assist is not available either.

The system is functioning differently than expected

1. Do not mount any objects on the steering wheel.

Comfort drive Travel Assist

Introduction

Thanks to the comfort drive Travel Assist, within the system limitations, the vehicle can maintain a distance, which has been preselected by the driver, to the vehicle in front and hold the preferred position within the lane (adaptive lane guidance).

Travel Assist uses the same sensor technology as the Adaptive Cruise Control (ACC) and Lane Keeping System (Lane Assist). Therefore, carefully read all the information about the ACC and Lane Assist and take note of the system limitations and notes specified in those sections.

Does this vehicle have Travel Assist?

The vehicle has Travel Assist, if the  button on the multi-function steering wheel is available.

Speed range

Travel Assist operates in a speed range between around 30 km/h (approximately 20 mph) and around 210 km/h (approximately 130 mph). This range is expanded to, from 0 km/h (0 mph) to around 250 km/h (approximately 155 mph), for the adaptive lane guidance. This speed range may vary depending on the country.

Driving with Travel Assist

Travel Assist automatically regulates the speed and steers the vehicle. Within the system limitations, Travel Assist can also bring the vehicle to a halt behind a

stopping vehicle and drive on again.

You can override the Travel Assist regulation function at any time.

Displays

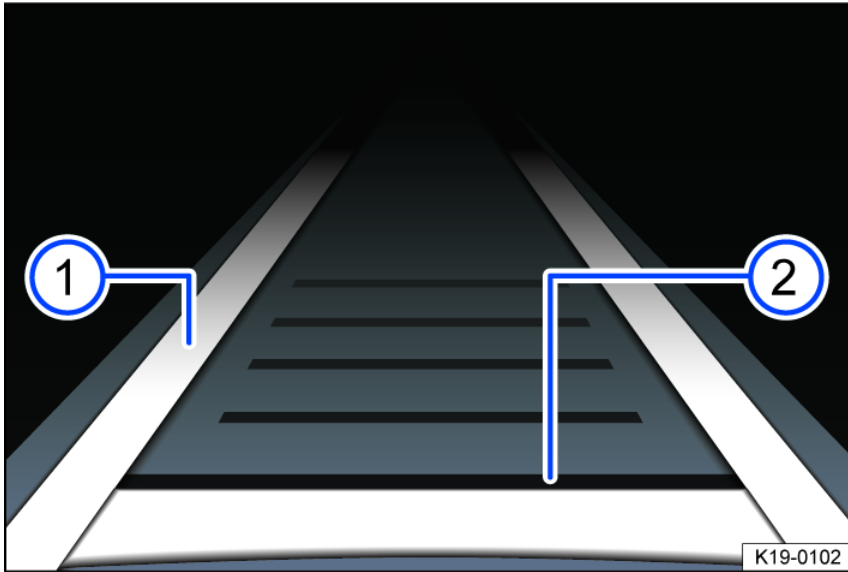



Fig. 115 In the instrument cluster display: Display during active control.

- ① Adaptive lane guidance is active.
- ② Set distance, no vehicle recognized in front.

Indicator lights on the instrument cluster display show the Travel Assist status, depending on the vehicle equipment:

 **Travel Assist active, Adaptive Cruise Control and adaptive lane guidance active.**  **Travel Assist active, Adaptive Cruise Control active and adaptive lane guidance passive.**

Driver intervention request

If you remove your hands from the steering wheel, the system will ask you to take over the steering wheel after a few seconds with a message in the instrument cluster display and with audible warnings.

If you do not respond, the system warns you with a brief braking maneuver.

Travel Assist is then deactivated.

Alternatively, Emergency Assist is activated, depending on the vehicle equipment.

WARNING

The intelligent technology of the Travel Assist cannot overcome the natural laws of physics, and it can only operate within the limits of the system. Careless or unintended use of the Travel Assist can cause accidents and serious injuries. The system cannot replace the driver's attention.

- Always adapt your speed and distance to vehicles driving ahead based on the visual, weather, road, and traffic conditions.
- Never use Travel Assist when visibility is poor or when roads are steep, winding, flooded, or slippery, for example from snow, ice, moisture, or gravel.
- Never use Travel Assist when driving off-road or on unpaved roads. Travel Assist is only designed for use on paved roads.
- Travel Assist does not react to persons, animals, vehicles crossing the lane or vehicles coming towards you in the same lane.
- Take over steering immediately if a driver intervention prompt appears in the instrument cluster display or the deceleration by the Travel Assist is not sufficient.
- Apply the brakes if the vehicle continues to roll unintentionally, e.g. after a driver intervention prompt.
- Always keep your hands on the steering wheel so that you are prepared to steer at any time. The driver is always responsible for keeping the vehicle within the lane.
- Always be ready to resume control of the vehicle speed.

Operating Travel Assist

 Please read the introductory information and heed the Warnings and Notice ⇒  **Introduction.**



Fig. 116 Left side of the multi-function steering wheel (variant 1).



Fig. 117 Left side of the multi-function steering wheel (variant 2).

Switching on and starting the regulation function

1. During forward travel with ACC switched on, press the  button on the multi-function steering wheel.

The vehicle switches from ACC to Travel Assist.

Depending on the driving situation, the vehicle switches to the following system status in Travel Assist:

- If ACC is regulating, Travel Assist maintains the current speed and the preset distance from the vehicle driving ahead (system status inactive).
At the same time, the vehicle is kept in its lane by steering movements when road markings are detected (system status active).
- If ACC is not regulating, Travel Assist is switched on, but stays deactivated.

1. Press the **SET** button.

Travel Assist switches the driving situation accordingly to an active or inactive system status.

The indicator/warning light corresponding to the driving situation comes on in the instrument cluster display. A notification is also displayed.

Canceling the regulation function

1. Press the  button briefly.

Or: Press the brake pedal.

The set distance remains saved.

Changing to ACC

1. Press the  button on the multi-function steering wheel.

The vehicle switches from Travel Assist to the system status of ACC corresponding to the driving situation.

Adjusting further settings

The further operation of Travel Assist corresponds to the operation of the ACC ⇒ [Adjusting the ACC settings](#).

Troubleshooting

 Please read the introductory information and heed the Warnings and Notice ⇒  [Introduction](#).

Comfort drive Travel Assist is not available or is not working as expected

The yellow indicator light turns on. In addition, a message is shown in the instrument cluster display.

- There is a malfunction in the sensor system. Check the causes and troubleshooting measures described in the information on ACC and Lane Assist.
- Malfunction or fault. Stop the engine and restart.
- The system limitations are not adhered to.
- If the problem persists, contact an authorized Volkswagen dealer or authorized Volkswagen Service Facility. Volkswagen recommends contacting an authorized Volkswagen dealer or authorized Volkswagen Service Facility.

Take over the steering

The white warning light will come on and a message will be shown in the instrument cluster display.

You have let go of the steering wheel for a few seconds.

1. Take hold of the steering wheel and take over steering the vehicle.

Take over the steering immediately

The red warning light will come on and a message will be shown in the instrument cluster display. An audible warning will sound or the steering wheel will vibrate, depending on the driving situation.

You have let go of the steering wheel for a long period of time or the system limits have been reached.

1. Immediately take hold of the steering wheel and take over steering the vehicle.

Comfort drive Travel Assist switches off automatically

- Vehicles without Emergency Assist:
You have let go of the steering wheel for a long period of time.
- Malfunction or fault. Stop the motor and restart.
- If the problem persists, contact an authorized Volkswagen dealer or authorized Volkswagen Service Facility. Volkswagen recommends contacting an authorized Volkswagen dealer or authorized Volkswagen Service Facility.

The regulation function is canceled unexpectedly

- You have operated the turn signal.

Semi-automatic vehicle control in a medical emergency (Emergency Assist)

Introduction

Emergency Assist can recognize driver inactivity and can automatically keep the vehicle in its lane and, if necessary, slow it down to a stop. The system can hereby actively help to avoid an accident or reduce the consequences of an accident.



Emergency Assist uses the same sensor technology as the Adaptive Cruise Control (ACC) and Lane Keeping System (Lane Assist). Therefore, carefully read all the information about the ACC and Lane Assist and take note of the system limitations and notes specified in those sections.

WARNING

The intelligent technology of the Emergency Assist cannot overcome the laws of physics, and it can only operate within the limits of the system. The responsibility for driving the vehicle always lies with the driver.

- Always adapt your speed and remain a safe distance to vehicles driving ahead according to the visual, weather, road, and traffic conditions.
- Emergency Assist alone cannot always avoid accidents and serious injury.
- If the radar sensor or the front camera malfunctions, is covered or misaligned, Emergency Assist may carry out unwanted braking or steering interventions.
- Emergency Assist does not react to people, animals, vehicles crossing the lane or vehicles coming towards you in the same lane.

Driving with Emergency Assist

 Please read the introductory information and heed the Warnings and Notice ⇒  **Introduction.**

Switching on and off

When the ignition is switched on, Emergency Assist is active under the following conditions:

- The Lane Assist system and Adaptive Cruise Control (ACC) are switched on.
- A gear is engaged for driving forward.
- The system must detect lane markers on the left and right side of the vehicle.

 **If the Lane Keeping System (Lane Assist) is not available, Emergency Assist is not available either.**

Driver intervention request

Using warning chimes and brief braking maneuver, Emergency Assist prompts an inactive driver to take over control of driving. In addition, a message is shown in the instrument cluster display.

System intervention

If you do not respond, the system can brake the vehicle and keep it in its lane. In the instrument cluster display, one of the following indicator lights comes on:

 **System is regulating.**

You can override the regulation at any time by accelerating, braking or steering.

Whenever Emergency Assist is actively controlling the vehicle, the emergency flashers will switch on after a short delay to warn other road users.

If the remaining stopping distance is sufficient, the vehicle slows down, if necessary, to a stop. The electronic parking brake then switches on automatically.

WARNING

If Emergency Assist is triggered unintentionally, it could result in accidents or serious injury.

- If the vehicle behaves unexpectedly, you can stop intervention by Emergency Assist by accelerating, braking or steering.
- Switch off the Lane Keeping System (Lane Assist).
- Do not use the comfort drive Travel Assist.
- Seek assistance from suitably qualified professionals and have the system checked. Volkswagen recommends contacting an authorized Volkswagen dealer or authorized Volkswagen Service Facility.

Lane Change System (Side Assist)

Introduction

The Lane Change System (Side Assist)
helps the driver to discern the traffic
situation behind the vehicle.

Radar sensors monitor the area behind the vehicle. The system measures the distance and difference in speed to other vehicles and informs the driver through visual signals in the outside mirrors.

System limitations

Only use the Lane Change System on secure roads.

The Lane Change System may not interpret the traffic situation correctly in some situations, for example:

- In tight curves.
- When driving in the center of two lanes.
- When lanes have different widths.
- When driving at the top of a hill.
- In poor weather conditions.
- When certain types of equipment are on the side of the road, such as high or offset guard rails.

WARNING

The intelligent technology of the Lane Change System (Side Assist) cannot overcome the laws of physics and it can only operate within the limits of the system. Do not allow the increased convenience of the Lane Change System (Side Assist) to tempt you into taking risks. Careless or unintended use of the Lane Change System (Side Assist) can cause accidents and serious injuries. The system cannot replace the driver's attention.

- Always adapt your speed and remain a safe distance to vehicles driving ahead according to the visual, weather, road, and traffic conditions.
- Always keep your hands on the steering wheel so that you are prepared to steer at any time.

- Pay attention to the displays in the outside mirror housings and in the instrument cluster display, and act accordingly.
- Always pay attention to the area around your vehicle.
- Never use the Lane Change System (Side Assist) if the radar sensors are dirty, covered up, or damaged. The function of the system may be impaired in such cases.
- Sunlight may reduce the visibility of the visual display in the outside mirror.

i The radar sensors calibrate once, on the first kilometer of a journey after the vehicle is delivered, and then again if the sensor technology has been repaired. The range of the sensors may be limited during the calibration phase.

Driving with the lane change system

📖 Please read the introductory information and heed the Warnings and Notice ⇒ **⚠️ Introduction.**

Switching on and off

You can view the switched on condition of Side Assist in the instrument cluster display and in the Infotainment system. You can also switch Side Assist on and off there.

In the instrument cluster display:

1. Press the  button.
2. Switch the Lane Change System (Side Assist) on or off.

i Depending on the vehicle equipment, the  button is located either on the multi-function steering wheel or the turn signal and high beam lever.

In the Infotainment system, depending on the vehicle equipment:

1. Open the Assistance systems menu.
2. Switch the Lane Change System (Side Assist) on or off in the corresponding submenu.



Fig. 118 In the outside mirror housing: Visual indicators for Side Assist.

When the Lane Change System (Side Assist) is switched on, the yellow indicator light  comes on once briefly in the outside mirror.

System function

The switched on lane change system is active from approximately 9 mph (approximately 15 km/h). The lane change system deactivates at a speed below approximately 6 mph (approximately 10 km/h).

In the following driving situations, the yellow indicator light  in the outside mirror will come on:

- When your vehicle is passed.
- When passing another vehicle and the difference in speed between the two vehicles is up to approximately 9 mph (approximately 15 km/h). There is no indicator if the passing speed is clearly faster.

When a potentially critical situation is detected while the turn signal is activated in the direction of the detected vehicle, the yellow indicator light  blinks in the outside mirror.

The faster another vehicle approaches, the sooner the display in the outside mirror will turn on.

Lane change system “Side Assist Plus”

In vehicle with a Lane Keeping System (Lane Assist), a corrective steering intervention warns you when a possibly critical situation is detected when changing lane (information level, warning level), if the Lane Keeping System (Lane Assist) is switched on. The steering intervention also occurs if you activate the turn signal for

the respective side. If you oversteer the steering intervention, an additional warning is provided by a steering wheel vibration. Steering wheel vibration must also be activated in the Assistance systems menu in the Infotainment system.

Automatic deactivation

The lane change system switches off automatically if the radar sensors are permanently covered. For example, this could be from ice or snow covering the radar sensor.

A message will appear in the instrument cluster display.

If the Lane Change System (Side Assist) is automatically deactivated, the system can be activated only after switching the ignition off and back on.

If you use the trailer hitch installed at the factory and have made the required electrical connection, the Lane Change System (Side Assist) will switch off automatically. Once you have disconnected the electrical connection, the Lane Change System (Side Assist) will be automatically switched on again. For trailer hitches that were not installed at the factory, you must switch the Lane Change System (Side Assist) off and on again manually.

Brightness

The brightness of the visual display adapts it self automatically to the ambient brightness.

You can set the default brightness of the display in the Assistance systems menu of the Infotainment system. The lane change system is not active while making the settings.

Troubleshooting

 Please read the introductory information and heed the Warnings and Notice ⇒  [Introduction](#).

Lane change system malfunctioning

Malfunction or fault. The yellow indicator light turns on. In addition, the yellow central warning light  comes on.

1. Contact a suitably qualified professional. Volkswagen recommends contacting an authorized Volkswagen dealer or authorized Volkswagen Service Facility.

Malfunctioning sensor view, malfunction message, system switches off automatically

- Clean the radar sensors and remove labels or accessories from the radar sensors ⇒ [Exterior care and cleaning](#).
- Check if there is any noticeable damage.
- If the problem persists, contact an authorized Volkswagen dealer or authorized Volkswagen Service Facility. Volkswagen recommends contacting an authorized Volkswagen dealer or authorized Volkswagen Service Facility.

The system is functioning differently than expected

- The radar sensors could be dirty ⇒ [Exterior care and cleaning](#). In addition to dirt and snow, the sensor range can also be impaired by soap residue or other coatings.
- The system conditions are not met ⇒  [Introduction](#).
- The radar sensors could be covered by water.
- The vehicle could be damaged in the radar sensor area, for example from parking barriers.
- The coverage areas of the radar sensors could be blocked by attachments, for example by bicycle carriers.
- The paint may have been changed or other structural modifications may have been made near the radar sensors, for example to the front of the vehicle or to the suspension.
- The side mirrors may be covered with after-market tinting films.
- If the problem persists, contact an authorized Volkswagen dealer or authorized Volkswagen Service Facility. Volkswagen recommends contacting an authorized Volkswagen dealer or authorized Volkswagen Service Facility.

Parking and maneuvering

Parking the vehicle

Parking

WARNING

Parking the vehicle incorrectly can result in the vehicle rolling, even on slight downhill slopes. This can cause accidents and serious injuries.

- When parking, always follow the steps in the specified order.
- Before exiting the vehicle, make sure the electronic parking brake is activated and the red warning light **PARK** comes on in the Volkswagen Digital Cockpit display once the ignition has been switched off.

1. Press and hold the brake pedal.
2. In vehicles with an automatic transmission, move the selector lever into the **P** position.
3. Set the electronic parking brake.
4. On uphill and downhill slopes, turn the steering wheel so that the vehicle will roll into a curb if it begins moving.
5. Stop the engine and switch the ignition off.

The red **PARK** indicator light in the instrument cluster display will turn on.

6. Release the brake.
7. Exit the vehicle ⇒ . Pay attention to other road users.
8. Take all vehicle keys with you and lock the vehicle.

WARNING

If children, people requiring assistance or animals are left unattended in the vehicle, there is a risk of accidents and serious injuries.

- Never leave children, people requiring assistance or animals unattended in the vehicle. They could move the selector lever, switching off the electronic parking brake. The vehicle could move.
- Never leave children, people requiring assistance or animals in the vehicle. Depending on the season, the temperature inside the vehicle could become very high or low.
- Always take all vehicle keys with you when leaving the vehicle.

To avoid damage and dangerous situations, always park the vehicle in a suitable parking area ⇒ .

NOTICE

Any unevenness in the ground, as well as sand and mud may mean that the vehicle cannot be parked safely and may be damaged.

- Always park the vehicle on solid and level ground.

NOTICE

Vehicle components that are low to the ground such as the bumpers, spoilers, and parts of the suspension could be damaged when driving over objects protruding up from the ground.

- Drive carefully over driveways, ramps, curbs and fixed barriers, as well as when driving through dips.

Electronic parking brake



Fig. 119 In the center console: button for the electronic parking brake.

Switching on

1. When the vehicle is stationary, pull and hold the button for the electronic parking brake  *fig. 119*.

The yellow indicator light in the  button comes on.

PARK If the electronic parking brake is switched on, the red indicator light comes on in the instrument cluster.

Switching off

1. Switch the ignition on.
2. Press the brake pedal and press the  button.

Or: when the engine is running, press the accelerator pedal lightly without pressing the brake pedal.

The indicator light in the  button and the red **PARK** warning light in the Volkswagen Digital Cockpit will turn off.

Automatic switch-on if you leave the vehicle incorrectly

In vehicles with an automatic transmission or DSG® automated transmission, if the system detects that the vehicle was exited incorrectly, it can switch on the electronic parking brake automatically ⇒ .

WARNING

Exiting the vehicle incorrectly can result in the vehicle rolling. This can cause accidents, serious injuries, and property damage.

- Always follow the specified steps in the correct order when parking the vehicle.
- Before exiting the vehicle, make sure the electronic parking brake is activated and the red **PARK** warning light in the Volkswagen Digital Cockpit display comes on after switching off the ignition.

Automatic switch-off when starting to drive

The parking brake releases automatically as you drive off if one of the following situations occurs when the driver's door is closed ⇒ :

- Automatic transmission: A gear is engaged or changed.

Starting to drive on steep inclines or with increased vehicle weight

You can prevent the electronic parking brake from releasing automatically if you pull the  switch upward and hold it up while starting to drive.

If more engine power is required when starting to drive, the electronic parking brake will release only after the  switch is released.

This can make it easier to start driving when towing a heavy load.

Emergency braking function

Only use the emergency braking function in an emergency, if the vehicle cannot be stopped using the brake pedal ⇒ .

1. Pull and hold the  switch.

The vehicle will brake abruptly. A warning chime will also sound at the same time.

WARNING

Using the electronic parking brake incorrectly can cause accidents and serious injuries.

- Always use the brake pedal to brake the vehicle and never the electronic parking brake unless it is an emergency. The braking distance will be significantly longer because only the rear wheels will be braked under certain circumstances.
- Do not press the accelerator pedal when the engine is running and a gear is engaged if the vehicle is to be brought to a standstill. The parking brake may

release and the vehicle could start to move.

 Noises can be heard when the electronic parking brake is operated or checked after a longer period.

Troubleshooting

PARK Holding force in the current situation is too low

The red warning light **PARK** is blinking.

It is not possible to park the vehicle safely.

1. Park the vehicle in another location or on a flat surface.

/ Electronic parking brake malfunction

The yellow central warning light comes on. The  symbol with a message is additionally shown in the instrument cluster display.

1. Contact an authorized Volkswagen dealer or authorized Volkswagen Service Facility. Volkswagen recommends contacting an authorized Volkswagen dealer or authorized Volkswagen Service Facility.

The electronic parking brake does not switch off

- The requirements for switching off the electronic parking brake are not met ⇒ [Electronic parking brake](#).
- The 12 V vehicle battery is drained ⇒ [Preparing and Performing a Jump-start](#).

Auto Hold



Fig. 120 In the center console: Auto Hold button (general example).

Auto Hold secures the vehicle from rolling away when it is stationary, without having to hold the vehicle with the brake pedal.

Depending on the vehicle equipment, your vehicle may feature the Auto Hold function.

Requirements

- ✓ The driver door must be closed.
- ✓ The engine must be stopped.

Auto Hold does not switch on or it switches off automatically if you shift into the **N** position. As a result, the vehicle will not be secured from rolling away ⇒ .

Switching on

1. Press the **AUTO HOLD** button [fig. 120](#).

The yellow indicator light in the **AUTO HOLD** button turns on.

Auto Hold is ready to use, but the vehicle may not be kept stationary ⇒ .

Auto Hold remains switched on after the ignition is turned on again.

Keeping the vehicle stationary using Auto Hold

1. When Auto Hold is switched on, bring the vehicle to a stop using the brakes.
2. Release the brake pedal.

The vehicle is kept stationary.

The hold on the vehicle will end when the vehicle starts to drive or the requirements for Auto Hold are not met.

Switching off

1. Press the **AUTO HOLD** button.

The indicator light in the **AUTO HOLD** *fig. 120* button turns off.

The electronic parking brake switches on automatically to keep the vehicle stationary.

However, if you press the brake pedal when switching off Auto Hold, the electronic parking brake will not switch on ⇒ ⚠.

Temporary switch-off with the button

It may be necessary to switch off Auto Hold temporarily, for example when maneuvering the vehicle to make it easier for the vehicle to roll.

1. With the engine running, press the brake pedal.
2. Press the  button.

Auto Hold is switched off.

Auto Hold will switch on again once the brake pedal is pressed while the vehicle is stationary.

⚠ WARNING

The intelligent technology of Auto Hold cannot overcome the natural laws of physics and it can only operate within the limits of the system. Do not allow the increased convenience provided by Auto Hold to tempt you into taking risks.

- Make sure the indicator light for the electronic parking brake in the instrument cluster display lights up if the vehicle is to be kept stationary.
- Never exit the vehicle when the engine is running and Auto Hold is switched on.
- In some situations, such as when the ground is slippery or icy, Auto Hold will not be able to keep the vehicle stationary on hills or brake it adequately when going downhill.

ⓘ NOTICE

Damage can result if the electronic parking brake switches on automatically in a car wash.

- Always switch off Auto Hold before going through a car wash.

Information about the parking systems

Safety instructions

⚠ WARNING

The intelligent technology of the Park Distance Control (PDC) cannot overcome the natural laws of physics and it can only operate within the limits of the system. Do not allow the increased convenience provided by the parking systems to tempt you into taking risks. The parking systems cannot replace the driver's attention.

- Always adapt your speed and driving style to the visibility, weather, road and traffic conditions.
- Always keep an eye on the parking direction and the vehicle surroundings. Pay particular attention to small children, animals and objects.
- Bear in mind that the parking system may not be able to react if the vehicle approaches too quickly and no warning is issued.
- Do not allow the parking system's display to distract you from the traffic around you.

⚠ WARNING

Camera lenses enlarge and distort the field of vision. Using the camera image to estimate the distance to people or obstacles may not be precise and can cause accidents and serious injuries.

- Do not rely on the camera system image.

ⓘ NOTICE

In parking spaces without a curb, park at least 20 inches (50 cm) away from walls and buildings to reduce the risk of vehicle damage.

Sensor and camera boundaries

Various sensors and cameras that detect the vehicle surroundings ultrasonically, by radar waves, and visually are located on and in the vehicle. The various parking systems use different combinations of sensors. All sensors have technical and physical limits ⇒ ⚠:

- In some situations, some objects may not be detected, e.g. trailer draw bars, narrow poles, fences, posts, and trees, extremely low or high obstacles, or trunk lids that are opening or already open ⇒ .
- The parking system coverage areas have “blind” spots in their range where they cannot detect people and objects.
- Dirt, ice, or water on the sensors and cameras may be detected as obstacles or prevent the detection of objects in some cases. In addition to dirt and snow, soap residue or other coatings can also impair the sensor range → page , *Exterior care and cleaning*.
- External noises and certain surfaces on objects and clothing can affect the sensor signals. In some situations, people and objects may not be detected or may be detected incorrectly.
- Certain objects, such as small posts or grating, cannot be shown or cannot be adequately shown due to the resolution of the screen and if there is insufficient lighting.
- The cameras only show two-dimensional images on the screen. Due to the lack of depth of field, it may be difficult or impossible to identify protruding objects or recesses in the road.

 **Volkswagen recommends practicing with the parking systems in a location or parking space with no traffic in order to become acquainted with the functions.**

Requirements

 **The use of parking systems, e.g. with camera assistance, may not be allowed in some regions according to legal provisions.**

- Use the parking systems only where permitted by legal provisions.

General information

So that the sensors and cameras can detect the area surrounding the vehicle as well as possible and display this image on the Infotainment system screen, the following requirements must be met.

- ✓ The doors and trunk lid are closed.
- ✓ The outside mirrors must not be folded in.
- ✓ The sensors or cameras are not covered by attachments or decorative license plate frames. The decorative number plate frame and the number plate itself must not protrude at the sides or bottom.
- ✓ The vehicle must be on level ground.
- ✓ The vehicle must not be loaded primarily in the rear or on one side.
- ✓ Engine is running.
- ✓ Braking assistance systems such as ESC or ASR are switched on.

 **If you use any other functions in the Infotainment system while you are parking, the parking function and its warning chimes will be deactivated.**

Finding a suitable parking space

- ✓ The length and width of the parking space must be larger than the vehicle measurements and provide enough space to maneuver.
- ✓ The distance when driving past the parking space is approx. 1 m (approx. 3 feet).
- ✓ **Vehicles with Park Assist:** The speed when passing the parking space is, for parking spaces parallel to the road, maximum approx. 40 km/h (approx. 25 mph), and for parking spaces across the road maximum approx. 20 km/h (approx. 12 mph).

Automatic braking intervention

A parking system's automatic braking support helps to avoid collisions, if an obstacle is detected.

Parking systems with braking support

Depending on the vehicle equipment, the vehicle has parking systems with a maneuvering and/or emergency braking function ⇒ .

WARNING

The increased comfort offered by the parking system automatic braking intervention should not cause you to take safety risks. In some situations, function of the automatic braking intervention may be limited or it may not function at all. Collisions with obstacles can lead to injuries and vehicle damage. The system cannot replace the driver's attention.

- Stay attentive and do not rely only on the parking systems.
- Always be ready to take over braking and steering.
- Do not take any risks when it comes to safety.
- React to the warnings and recommendations from the parking systems.

Requirements

- ✓ When maneuvering, the vehicle is not driving faster than approx. 10 km/h (approx. 6 mph).
- ✓ A parking system has been switched on.

What happens during an automatic braking intervention?

If there is an obstacle, the vehicle brakes to a stop and is kept stationary for around two seconds.

1. After braking, press the brake pedal to keep the vehicle stationary.
2. Check your surroundings.

Park Assist: If the speed is too high, the vehicle will brake to a stop. The parking process can then be resumed.

Depending on the vehicle equipment, there may be a message on the instrument cluster display.

Switching on and off

Automatic braking is activated or deactivated when a parking system is switched on or off by the driver.

1. **Or:** Tap the  function key in the screen display of the parking system.

Maneuver braking for Park Distance Control

1. Briefly press the accelerator pedal to cancel the automatic braking support ⇒ .

 **If there is an obstacle in the front area of the vehicle, automatic braking support will not happen if Park Distance Control was activated automatically while driving forward ⇒ *Switching Park Distance Control (PDC) on and off.***

Driving with a trailer

If a trailer is connected electrically, the automatic braking support in the rear area is deactivated.

If the trailer hitch was not installed at the factory, the parking system must be manually deactivated when towing a trailer.

General information

 **Switch the parking system off if automatic braking support happens too frequently, like when driving off-road.**

 **If the maneuver braking function for Park Distance Control intervenes to stop the vehicle, the function will be inactive for a distance of approx. 5 m (approx. 16 ft) when driving in the same direction. It will become active again if the gear or selector lever position changes.**

 **The parking process is canceled following Park Assist emergency braking due to an obstacle.**

 **Following a Rear Traffic Alert emergency braking intervention, it will take approx. 10 seconds before automatic braking support can occur again.**

Troubleshooting

The parking system is functioning differently than expected

- The system conditions are not met ⇒ *Requirements.*
- The sensors or camera may be dirty or covered with ice ⇒ *Exterior care and cleaning.*
- The camera lens is dirty and the camera image is not clear ⇒ *Exterior care and cleaning.*
- Sources of noise, such as a jackhammer or driving over cobblestones, can interfere with the ultrasonic signal.
- The vehicle is damaged in the area of the sensors or camera, for example from parking barriers, or the paint may have been changed or other structural modifications may have been made near the sensors or camera, for example to the vehicle front end or to the suspension.
- The areas detected by the sensors or camera may be blocked by accessories such as bicycle racks.

Fault displays

1. Note any messages on the instrument cluster display and in the Infotainment system.

NOTICE

Contact an authorized Volkswagen dealer or authorized Volkswagen Service Facility in the event of a parking system malfunction. Volkswagen recommends contacting an authorized Volkswagen dealer or authorized Volkswagen Service Facility.

No sensor or camera view or the parking system has been switched off

If a sensor malfunctions, the sensor area is deactivated. The sensor area affected can be displayed in the Infotainment system by the  symbol. The parking system may be completely switched off.

If Park Distance Control is malfunctioning, a continuous tone will sound for several seconds when you switch it on. Where applicable, a message will appear in the instrument cluster display.

1. Check if one of the causes listed is responsible.
2. Once the source of the issue has been resolved, switch the system on again.

- If the problem persists, contact an authorized Volkswagen dealer or authorized Volkswagen Service Facility. Volkswagen recommends contacting an authorized Volkswagen dealer or authorized Volkswagen Service Facility.

The Park Assist is canceled automatically

Park Assist will end the parking process if one of the following situations occurs:

- The **P** function key is pressed.
- The driver takes over steering.
- The driver's door is opened.
- The time limit or number of movements for the parking process is exceeded.
- ASR is switched off or it engages.
- There is a system malfunction.

- Restart the parking process.

Park Assist is active and supports steering movements when the vehicle is stationary

If Park Assist attempts to turn the steering while the vehicle is stationary, the white  symbol appears in the instrument cluster display.

- Press the brake pedal.

After a wheel change, Park Assist parks inaccurately

If, after a wheel change, Park Assist parks inaccurately, e.g. with an increased or reduced distance from the curb, the system may have to acquire the wheel sizes again.

- Drive the vehicle over a longer distance, including around bends.

The Park Assist system automatically learns the new wheel sizes.

Park Distance Control (PDC)

Introduction

Park Distance Control assists the driver when parking and warns if there are obstacles.

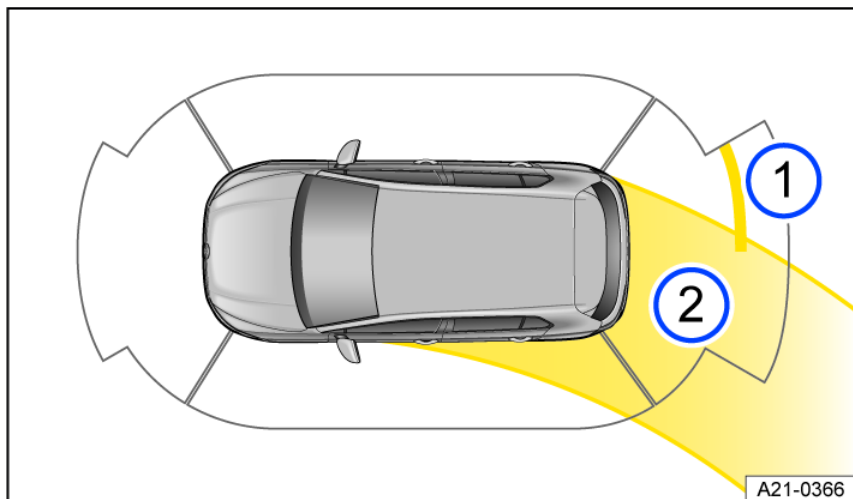



Fig. 121 Infotainment system: Display of Park Distance Control (general example).

-  Obstacle detection.
-  Steering lock.

System function

Using ultrasound sensors, the Park Distance Control detects the distance of the vehicle from an obstacle.

The Park Distance Control warns you of a collision via colored segments on the screen of the Infotainment system and via warning chimes [fig. 121](#), ⇒ .

If the driver does not respond to an approaching obstacle, automatic braking support may intervene (depending on the vehicle equipment) ⇒ .

WARNING

The intelligent technology of the Park Distance Control (PDC) cannot overcome the natural laws of physics and it can only operate within the limits of the system. Not paying attention can result in accidents, serious injuries and vehicle damage.

- The PDC cannot replace the driver's attention.

NOTICE



The collision area has been reached, at the latest, when the penultimate segment is displayed or a continuous warning tone sounds.

- Brake the vehicle in good time before reaching an obstacle.

NOTICE

Depending on the vehicle equipment, distances to obstacles in the side areas are also displayed. In order to fully scan and display the side areas, you must move the vehicle a few yards forward or back. Any obstacles that enter these areas from the outside are not displayed.

Screen display

Red section of the image: Nearby obstacle. The vehicle is at risk. Apply the brakes. **Yellow section of the image: Obstacle in the path of the vehicle. The vehicle is at risk. Steer around the obstacle.** **White or gray section of the image: Obstacle outside of the vehicle's path.**  **Mute the warning chimes.**  **Switch maneuver braking on and off (depending on the vehicle equipment).** **There is a system malfunction in the area that is detected (depending on vehicle equipment). The colors may vary.**

NOTICE

The system will only provide visual and audible warnings for obstacles within the vehicle's path.

Park Distance Control settings

Depending on the vehicle equipment, settings for the Park Distance Control can be adjusted in the vehicle settings in the Infotainment system → [Vehicle settings menu](#).

Special considerations when towing a trailer

If a trailer electrical system is connected, the rear sensors of the Park Distance Control are not switched on:

- You are not warned about obstacles.
- The maneuver braking is also deactivated automatically.

Switching Park Distance Control (PDC) on and off

 Please read the introductory information and heed the Warnings and Notice  and  Safety instructions.



Fig. 122 In the center console: Park Distance Control button.

Switching on

1. Select the reverse gear.

Or: Press the  button [fig. 122](#).

Or: Press the  button.

Or: The vehicle will roll backward.

Switching off

1. Press the  button *fig. 122*.

Or: Press the  button.

Or: engage the **P** selector lever position.

Or: the vehicle is driving forward at more than approx. 10 km/h (approx. 6 mph) up to approx. 15 km/h (approx. 9 mph).

Automatic activation when driving forward

If the vehicle slowly approaches an obstacle, Park Distance Control is automatically activated.

1. Switch the function on or off in the Infotainment system vehicle settings ⇒ *Vehicle settings menu*.

If the driver switches off Park Distance Control, no further automatic activation occurs.

Automatic activation is available again under following conditions:

- The vehicle has been accelerated to more than approx. 15 km/h (approx. 9 mph) and then the speed has fallen below this again.

Or: the ignition has been switched off and on again.

Or: parking lock **P** has been changed to a gear.

 **If an obstacle is detected in front of the vehicle, the display in the Infotainment system is activated. If the vehicle approaches further, warning chimes also sound.**

Rear View Camera (Rear View)

Introduction

The Rear View Camera system in the rear of the vehicle makes it easier for the driver to see behind the vehicle and assists when parking.

System function

The Rear View Camera system shows the area behind the vehicle on the Infotainment system screen. Depending on the mode and vehicle equipment, orientation lines may assist in the view toward the rear ⇒ .

WARNING

The intelligent technology of the Park Distance Control (PDC) cannot overcome the natural laws of physics and it can only operate within the limits of the system. Not paying attention can result in accidents, serious injuries and vehicle damage.

- The PDC cannot replace the driver's attention.
- Brake the vehicle in good time before reaching an obstacle.

 **The orientation lines superimposed on the camera image are shown by the system regardless of the vehicle's surroundings. There is no automatic obstacle detection by the camera while it is active. The driver must evaluate whether the vehicle will fit in the parking space.**

 **If a trailer is connected to the factory-installed trailer hitch, all orientation lines for the rear area are hidden in the camera image.**

 **If a camera is installed in the trunk lid, the orientation lines are also hidden if the trunk lid is open.**

USA and Canada: If the camera image on a parking system has been switched on by engaging the reverse gear, no function keys are displayed for safety reasons. These function keys can be displayed again by tapping the function key .

CAUTION

Vehicles with a swiveling emblem: The Rear View Camera system extending can cause serious injuries due to entrapment.

- When engaging reverse gear, make sure that there are no persons directly behind the vehicle and that nobody can intervene in the range of operation of the Volkswagen emblem on the trunk lid.

Switching the Rear View Camera system on and off

 Please read the introductory information and heed the Warnings and Notice ⇒  and  *Safety instructions*.

Switching on

Rear View Camera system with parking mode selection:

1. Select the reverse gear.

Or: Press the  button.

Switching off

Rear View Camera system with parking mode selection:







1. The vehicle drives at more than approx. 9 mph (approx. 15 km/h).

Or: Press the  button.

Parking (Rear View Camera system with parking mode selection)

 Please read the introductory information and heed the Warnings and Notice  and  Safety instructions.

Screen display

 **Perpendicular parking:** Guide lines help when parking in reverse perpendicular to the road.  **Parallel parking:** Guide lines and boxes help when parking in reverse parallel to the road.  Turn the steering wheel (parallel parking mode).  Stop the vehicle (parallel parking mode).  **Cross traffic:** Depiction of the area behind the vehicle and the areas to the side of the vehicle at a wide angle.  **Trailer or terrain assistance:** Depiction of the area immediately behind the vehicle with a high zoom factor and guide lines.  **Red line:** Boundary or safety distance from the vehicle.

Red frame: Outline of the vehicle (parallel parking).

 **Yellow lines:** the vehicle's path based on the steering angle.

Yellow assisting box: front or rear edge of the parking space (parallel parking)

 **Green horizontal lines:** Boundaries.

Green line on the side: turning point when parking (parallel parking).

Green frame: outline of the vehicle (parallel parking).

 **Adjust the brightness, contrast, and color.**

Parking mode: Parking perpendicular to the road

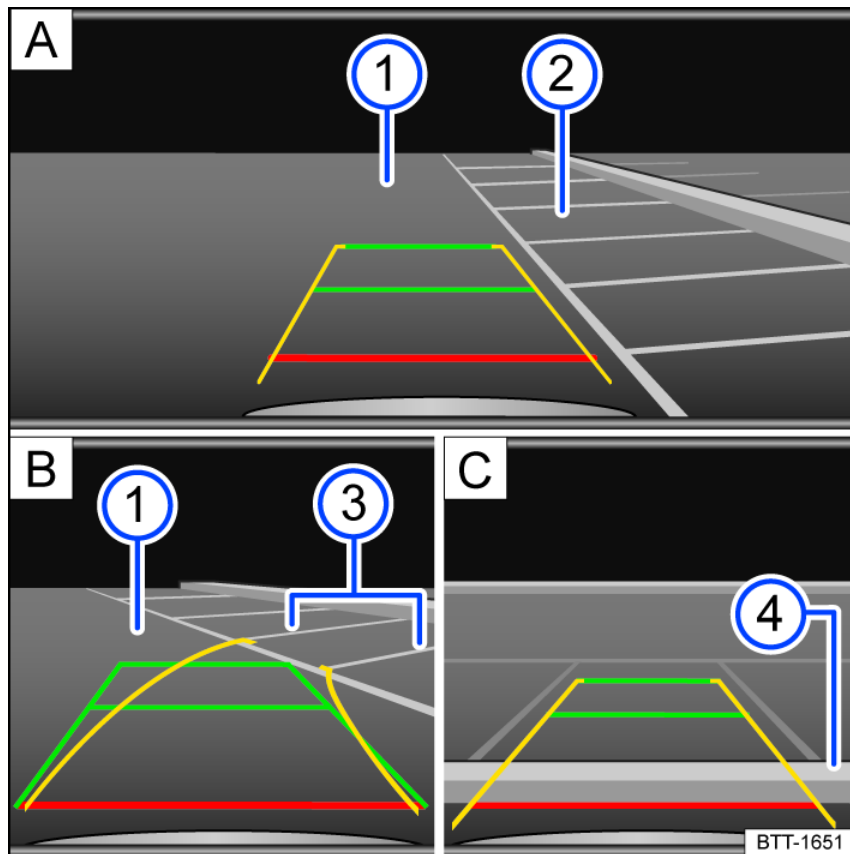













Fig. 123 Infotainment system: Parking perpendicular to the road.

-  Searching for a parking space.
-  Steering toward the selected parking space.
-  Aligning the vehicle within the parking space.

-  Road surface.
-  Parking space.
-  Side boundary of the parking space.
-  Rear boundary of the parking space.

1. Press the  button or function key before driving past the parking space.
2. Tap the  function key in the Infotainment system to select the parking mode.
3. Position your vehicle in front of the parking space *fig. 123*  .

- Steer so that the yellow lines lead into the parking space. The green and yellow lines must align with the side boundary lines [fig. 123](#) **B** [3](#).
- Stop when the red line reaches the rear boundary [fig. 123](#) **C** [4](#).

Parking mode: Parallel parking

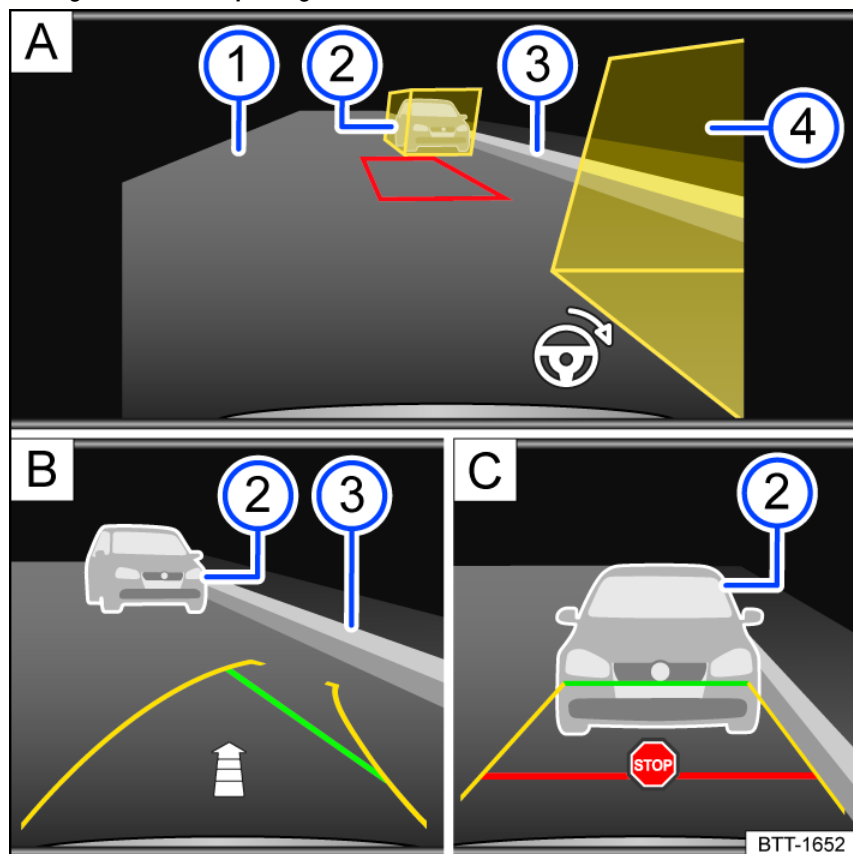





Fig. 124 Infotainment system: Parking parallel to the road.

- A** Searching for a parking space.
- B** Steering toward the selected parking space.
- C** Aligning the vehicle within the parking space.

- [1](#) Road surface.
- [2](#) Obstacle or assisting box.
- [3](#) Side boundary of the parking space.
- [4](#) Obstacle or assisting box.

- Press the **P/A** button or function key before driving past the parking space.
- Tap the **PA** function key in the Infotainment system to select the parking mode.
- Turn on the turn signal for the corresponding side of the road.
- Position the vehicle at a distance of approximately 1 m (3 ft) parallel to the parking row. The yellow assisting boxes must cover the obstacles [fig. 124](#) **A** [2](#) [c](#) [4](#). The area in between must be free of obstacles.
- Select the reverse gear. A red frame represents the target position of your vehicle [fig. 124](#) **A**.
- Turn the steering wheel until the red frame moves between the assisting boxes and becomes green [fig. 124](#) **A**. Hold the steering wheel in this position while driving in reverse.

If the steering wheel angle needs to change, one of the yellow side lines will become red. The  steering wheel symbol indicates to the driver when the steering wheel must be turned.
- Drive slowly in reverse until the  stop symbol appears or the green line aligns with the side boundary of the parking space [fig. 124](#) **C**. An [fig. 124](#) **B** arrow indicates the remaining distance to be driven based on the number of displayed segments.
- Stop the vehicle. Steer in the opposite direction until the steering angle is reached and a direction arrow is no longer displayed.
- Keep driving in reverse until the  stop symbol appears or until the red line reaches the rear boundary.

Parking mode: Trailer support

On vehicles with a trailer hitch installed at the factory, trailer support can be used for assistance when attaching the trailer to a draw bar.

- Tap the  function key to select the parking mode.

Colored guide lines help you with the maneuvering process.

Red lines: position of the trailer hitch. Green lines: distance to the trailer hitch. Orange line: predicted direction of the trailer hitch based on the steering wheel angle.

Area View

Introduction

The Area View shows the entire vehicle environment in real time. This function helps you recognize obstacles in good time in situations where there might be blind spots.

System function

The system uses multiple cameras to create images of the vehicle environment, which are then displayed on the Infotainment system screen ⇒ ⚠.

The functions and displays of the Area View may vary depending on the vehicle equipment, e.g. if Park Distance Control is available and is also displayed.

⚠ WARNING

The intelligent technology of the Park Distance Control (PDC) cannot overcome the natural laws of physics and it can only operate within the limits of the system. Not paying attention can result in accidents, serious injuries and vehicle damage.

- The PDC cannot replace the driver's attention.

Switching on and off

📖 Please read the introductory information and heed the Warnings and Notice ⇒ ⚠ and ⚠ Safety instructions.



Fig. 125 In the center console: Button for switching the Area View on and off.

Switching on

1. Select the reverse gear.

Or: Press the  button *fig. 125*.

Switching off

1. Drive faster than approx. 9 mph (approx. 15 km/h).

Or: Press the  button *fig. 125*.

Changing the camera perspective

📖 Please read the introductory information and heed the Warnings and Notice ⇒ ⚠ and ⚠ Safety instructions.

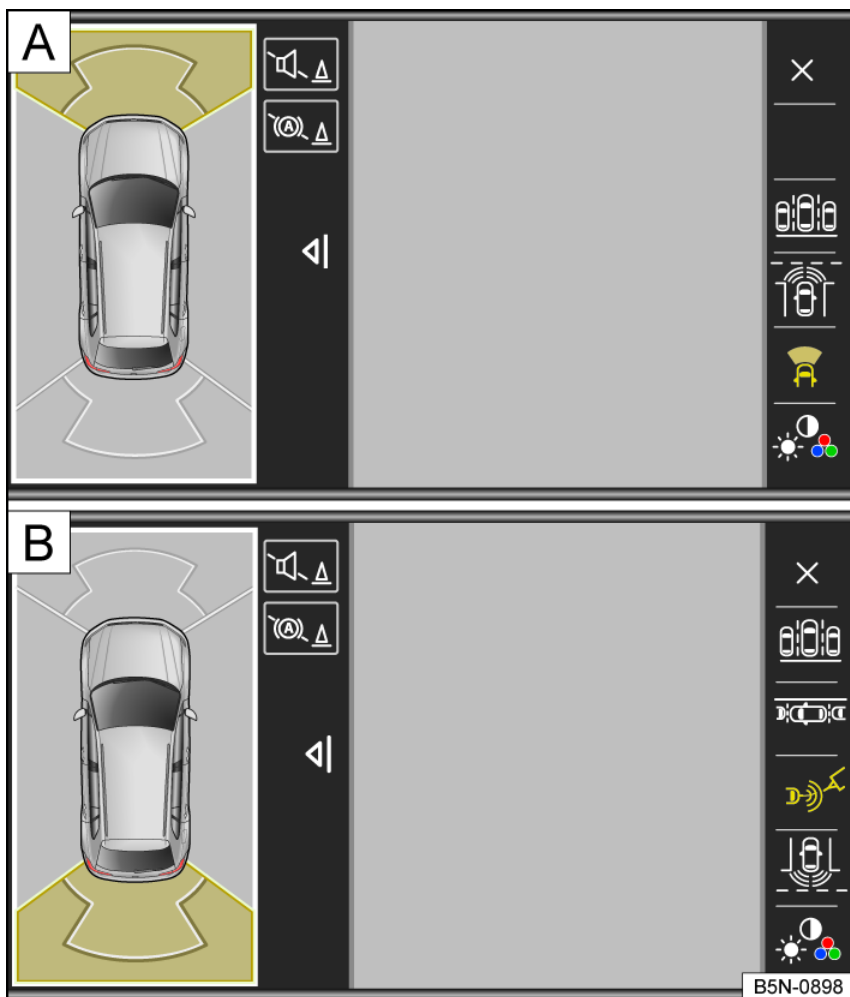

Fig. 126 Infotainment system: screen display of Area View.

- A** Front camera.
- B** Rear camera.

Switching between camera images

1. Tap the function keys on the image border to select a display *fig. 126*.

Sections of the screen

Two sections of the screen will be shown in the Infotainment system *fig. 126*:

Left screen The vehicle is displayed from a bird's-eye view. By tapping on one section, the display changes to the right section of the screen.

Right screen Depending on the section selected on the left screen, separate camera images will be displayed.

3D view of the Area View

A 3D view may be available, depending on the vehicle equipment.

1. Swipe in the direction of the arrows on the screen to change the angle of the 3D view.

Screen display

Front perpendicular parking.
 Rear perpendicular parking.
 Front cross traffic.
 Rear cross traffic.
 Off-road.
 Display both areas next to the vehicle at the same time.
 Display the driver's side only.
 Display the passenger's side only.
 Switch to trailer or off-road support (depending on the country).
 3D views.
 Switch to top view of the vehicle and surrounding area.
 Top view of the vehicle and surrounding area (3D view) from directly above.
 Top view of the vehicle and surrounding area (3D view) from diagonally above.
 Vehicle and surrounding area from the side (3D view).

Park Assist

Introduction

Park Assist displays a suitable parking space and assists the driver when parking and leaving the parking space.

System function

Park Assist is an extension of the parking system.

Park Assist steers the vehicle into a parking space while you operate the accelerator pedal, the gears and the brake ⇒ ⚠.

⚠ WARNING

The intelligent technology of the Park Distance Control (PDC) cannot overcome the natural laws of physics and it can only operate within the limits of the system. Not paying attention can result in accidents, serious injuries and vehicle damage.

- Pay close attention to the parking process and the traffic. Keep an eye on the parking direction at the same time.
- In a hazardous situation, apply the brakes using the brake pedal.

Available functions

- Display suitable parking spaces.
- Select parking mode.
- Driving into a suitable parallel parking space or parking bay.
- Driving out of a suitable parallel parking space.

ⓘ NOTICE

Park Assist orients itself to parked vehicles, curbs, or other objects. Make sure that adjacent vehicle parts such as tires and rims are not damaged when parking.

- If necessary, press the brake pedal and end the parking process.

🔧 **Aftermarket accessories mounted on the vehicle, such as bicycle racks, can interfere with Park Assist and can cause damage.**

🔧 **Automatic braking support may occur during parking processes if the driver accelerates too much.**

Driving with a trailer

Park Assist cannot be activated if a trailer is connected to the electrical system.

If the trailer hitch was not installed at the factory, Park Assist must be manually deactivated in trailer mode.

Searching for parking spaces

📖 Please read the introductory information and heed the Warnings and Notice ⇒ ⚠ and ⓘ Safety instructions.



Fig. 127 In the center console: Park Assist button.

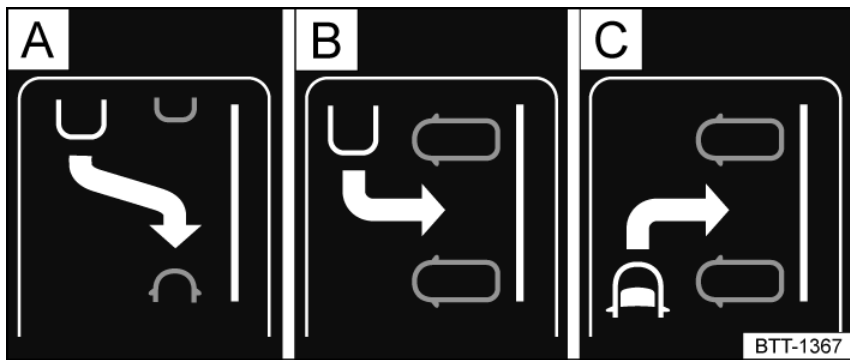

Fig. 128 In the instrument cluster display: park modes for driving into parking spaces.

- A** Parallel parking in reverse.
- B** Cross parking in reverse.
- C** Cross parking driving forward.

Searching for parking spaces

1. Press the  button *fig. 127*.

The yellow indicator light turns on and the parking function is active.

2. While paying attention to traffic around your vehicle, drive slowly past a row of parked vehicles.

Park Assist will automatically search for a suitable parking space.

Or: press the turn signal to look for a parking space on the opposite side of the road.

If a parking space is found, a parking mode will be displayed *fig. 128*.

3. If, for example, you would like to drive forward to park in a space at an angle to the road, press the  button and select parking mode *fig. 128* **C**.

Or: to select multiple parking spaces displayed in a row, press the  button multiple times.

WARNING

There is the risk of an accident, if you open and use another function besides the parking function on the Infotainment system while maneuvering with the Park Distance Control or the Park Assist. If this happens, all active parking functions, including the audible warnings, are shut down. You will therefore no longer be warned about a possible collision or receive intervention.

- Do not use any other Infotainment system functions while maneuvering, other than the active parking function.

 **Park Assist can be activated afterwards. If you drive past a suitable parking space, this will be indicated.**

Driving into parking spaces

 Please read the introductory information and heed the Warnings and Notice  and  **Safety instructions.**

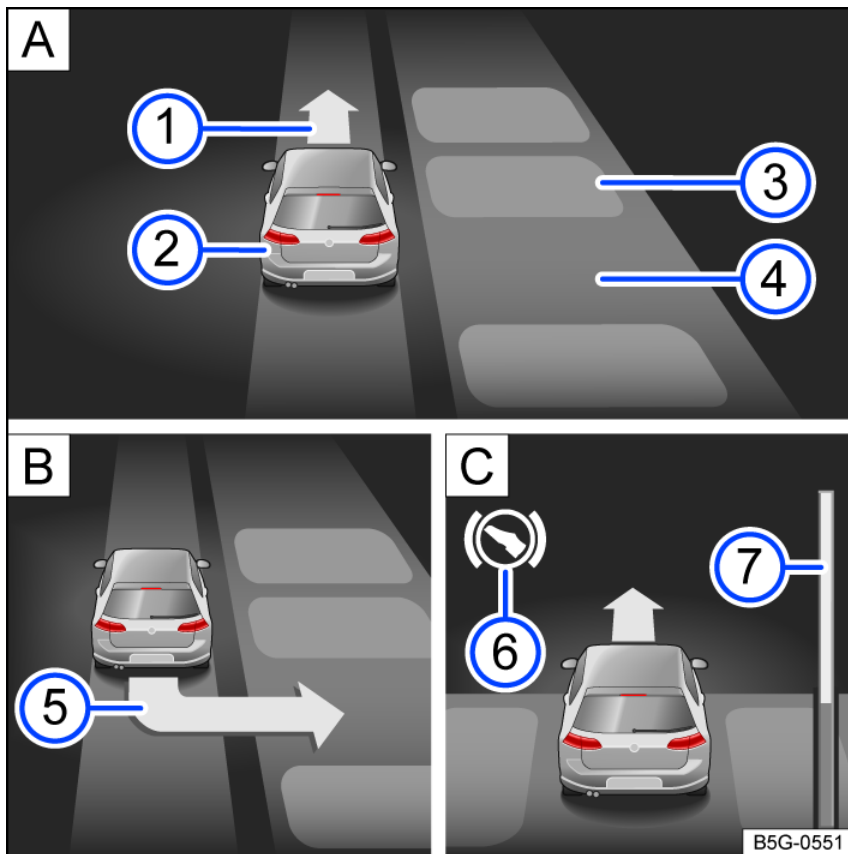



Fig. 129 In the instrument cluster display: parking perpendicular to the road.

- A** Searching for a parking space.
- B** Driving into a parking space.
- C** Maneuvering into a parking space.

- ① Prompt to drive forward.
- ② Your vehicle.
- ③ Parking vehicle or obstacle.
- ④ Detected parking space.
- ⑤ Request to drive backwards.
- ⑥ Request to brake.
- ⑦ Progress bar (relative distance remaining).

1. Stop the vehicle in front of or behind the parking space.
2. Pay attention to the prompt for parking in the instrument cluster display *fig. 129* ⑤.
3. Engage reverse gear if a backwards arrow appears in the instrument cluster display.
4. Release the steering wheel.
5. Release the brake.
6. Pay attention to the messages and indicators in the instrument cluster display.
7. Accelerate carefully.
8. Apply the brakes if a warning chime sounds, the  indicator lights up, or a message appears on the instrument cluster display.
9. At the end of a parking maneuver, always wait until Park Assist has completed all rotational movements of the steering wheel in order to achieve an optimum parking result ⇒ .
10. Carry out several parking maneuvers if necessary.
 - When the process of driving into a parking space is finished, a text message appears in the instrument cluster display.
11. Park the vehicle ⇒ *Parking*.

⚠ WARNING

Turning the steering wheel too quickly can cause serious injuries.

- Do not grab the steering wheel during the maneuver until the system prompts you to do so.
- If the vehicle is approaching a dangerous situation, take over the steering.

Exiting a parking space

📖 Please read the introductory information and heed the Warnings and Notice ⇒ ⚠️ and 🚨 Safety instructions.

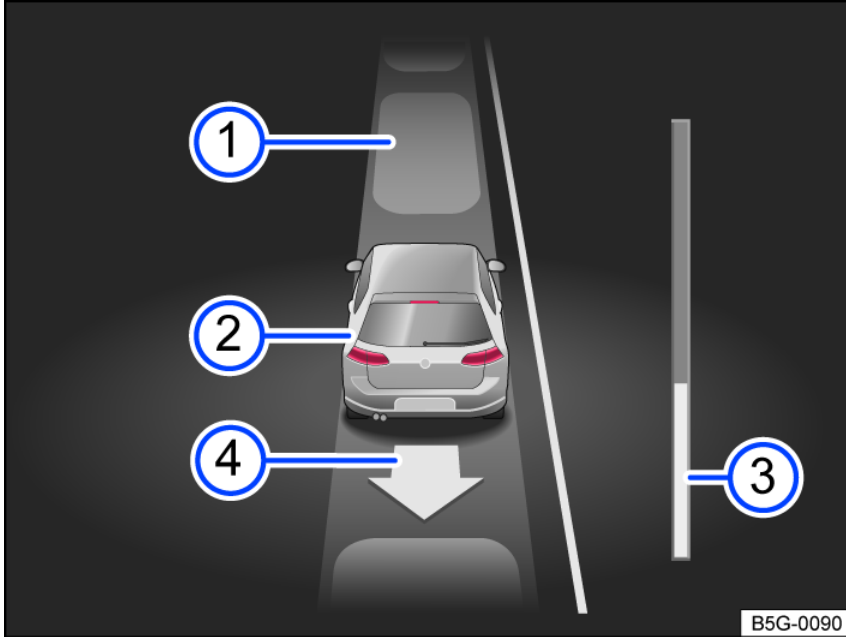

Fig. 130 In the instrument cluster display: reversing out of a parking space parallel to the road.

- ① Vehicle parking.
 - ② Your vehicle.
 - ③ Progress bar (relative distance remaining).
 - ④ Direction of travel when driving out of a parking space.
1. Press the **P** button.
 2. Activate the turn signal for the side of the road where the vehicle should drive out of the parking space.
 3. Select the reverse gear.
 4. Let go of the steering wheel when the message **Steering intervention active! Check surrounding area.** is displayed.
 5. Accelerate carefully.
 6. Apply the brakes if a chime sounds, the 🚨 indicator turns on, or once the prompt to drive forward appears in the instrument cluster display.
 7. Perform the procedure for exiting the parking space until a message appears in the instrument cluster display and possibly a tone signaling the end of the parking space exit procedure.
 8. Press the brake pedal until the steering movements from Park Assist have stopped or the 🚨 indicator in the instrument cluster display turns off.
 9. Take over steering with the steering wheel at the angle already set.
 10. Drive the vehicle out of the parking space ⇒ ⚠️.

⚠️ WARNING

Only drive the vehicle out of the parking space when the traffic situation allows it.

Rear Traffic Alert

Rear Traffic Alert monitors the cross traffic when reversing out of a space or maneuvering.

⚠️ WARNING

The intelligent technology of the Park Distance Control (PDC) cannot overcome the natural laws of physics and it can only operate within the limits of the system. Not paying attention can result in accidents, serious injuries, and vehicle damage.

- Pay attention to the traffic situation and the vehicle environment.
- The Rear Traffic Alert may potentially not detect all approaching objects, e.g. pedestrians or objects approaching quickly.

Switching on and off

1. Press the  button.

Or: Depending on the vehicle equipment, press the button for driver assistance systems.

Or: Depending on the vehicle equipment, open the vehicle settings in the Infotainment system ⇒ *Vehicle settings menu*.

2. Switch Rear Traffic Alert on or off.

System function

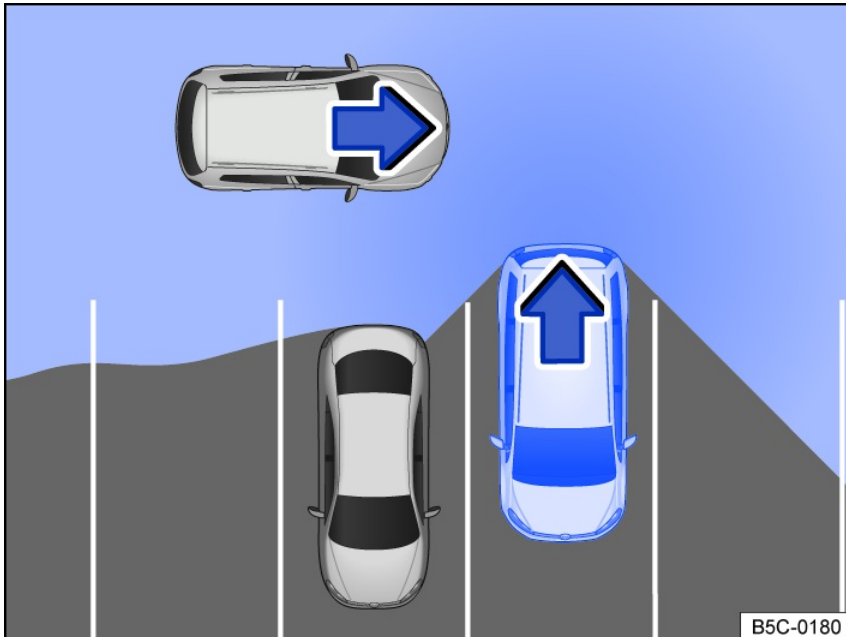

Fig. 131 Rear Traffic Alert, general example: monitored area around the vehicle that is exiting a parking space.

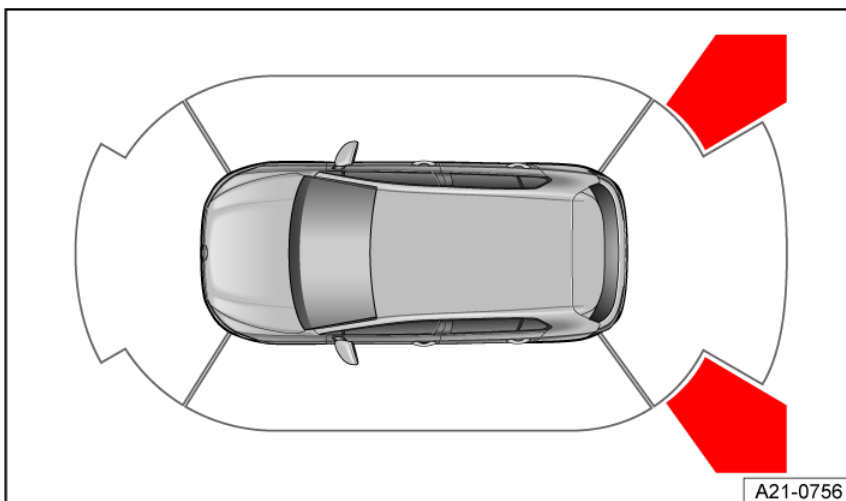



Fig. 132 Infotainment system: Rear Traffic Alert display (general example).

The Rear Traffic Alert functions with radar sensors in the rear bumper.

The system detects approaching or moving objects in the surrounding area to the rear and to the side and warns the driver if there is an obstacle [fig. 131](#), ⇒ 

If there is an obstacle, a warning signal will sound. Depending on the vehicle equipment, a color indication of the obstacle zone appears in the Infotainment system [fig. 132](#) and/or a warning or indicator light appears in the instrument cluster along with a message.

If the driver does not respond, automatic braking support may kick in.

 **Obstacle detected.**

1. Beware of traffic behind the vehicle.

 **Automatic braking intervention by Rear Traffic Alert.**

1. Press the brake pedal to bring the vehicle to a standstill.

 **If Park Distance Control is deactivated, the driver cannot be sent any feedback. Rear Traffic Alert is also temporarily deactivated.**

Driving with a trailer

Rear Traffic Alert cannot be activated if a trailer is connected to the electrical system.

If the trailer hitch was not installed at the factory, Rear Traffic Alert must be manually deactivated when towing a trailer.

Braking assistance systems

Information about braking assistance systems

Braking assistance systems can assist the driver in critical driving and braking situations. The driver is always responsible for safe driving ⇒ ⚠.

1. If a braking assistance system is regulating, continue braking with the necessary force. If necessary, steer the vehicle.

⚠ WARNING

The intelligent technology in the braking assistance systems cannot overcome the natural laws of physics and it can only operate within the limits of the system. Driving fast on icy, slippery, or wet roads can lead to loss of vehicle control and serious injuries to the driver and passengers.

- Always adapt your speed and driving style to the visibility, weather, road and traffic conditions. Do not take any risks.
- Braking assistance systems cannot prevent a collision, for example if you are driving too close to other vehicles.
- Always use suitable tires. Driving stability depends on the tires' ability to grip the road.
- Always keep the footwell beneath the pedals clear so that the brake pedal is unobstructed and can move freely.
- ESC, ABS and ASR only function correctly when all four wheels have the intended tires ⇒ ⚠.
- If the ABS malfunctions, the ESC, ASR and EDS also fail.

When the ignition is switched on, the condition of the braking functions is automatically checked. The indicator lights will come on briefly and then turn off. If an indicator light remains on permanently, there is a malfunction. Contact an authorized Volkswagen dealer or authorized Volkswagen Service Facility immediately. Volkswagen recommends contacting an authorized Volkswagen dealer or authorized Volkswagen Service Facility.

⚠ WARNING

The effectiveness of the ESC can be reduced considerably if other components and systems that affect driving dynamics are not maintained correctly or are malfunctioning. This applies in particular to changes made to the suspension and any non-approved wheel and tire combinations.

- Ensure that conversion and modifications to the vehicle are only performed by an authorized Volkswagen dealer or authorized Volkswagen Service Facility. Volkswagen recommends contacting an authorized Volkswagen dealer or authorized Volkswagen Service Facility.
- Always use suitable tires. Driving stability depends on the tires' ability to grip the road.

Electronic Stability Control (ESC)



ESC is regulating the vehicle to reduce the risk of skidding and improve driving stability ⇒ ⚠. The indicator light flashes yellow.

Anti-Slip Regulation (ASR)



ASR is regulating the vehicle to reduce the risk of the wheels spinning. The indicator light flashes yellow.

ASR reduces drive power at wheels that are spinning and adapts the drive power to the road conditions. ASR makes it easier to start, accelerate, and drive up hills ⇒ ⚠.

Anti-Lock Braking System (ABS)

ABS prevents the wheels from locking during braking so that the vehicle can be steered ⇒ ⚠.

Brake Assist System (BAS)

BAS can help to reduce the vehicle braking distance. BAS increases braking power when the driver presses the brake pedal quickly in emergency situations ⇒ ⚠.

Electronic Differential Lock (EDL and XDL)

EDS automatically applies the brakes to a wheel that starts spinning and transfers the drive power to the other driving wheels.

XDS is an extension of the electronic differential lock, and improves traction with braking support to help keep the vehicle in its lane.

Multi Collision Brake

The Automatic Post-Collision Braking System automatically brakes the vehicle if the airbag control module has detected a collision in an accident situation.

Requirements for automatic braking:

- ✓ The driver does not press the accelerator pedal.

Electronic braking distribution (EBD)

The electronic braking distribution (EBD) regulates the braking force between the front axle and the rear axle, even outside of ABS regulation. Overbraking of the rear axle is avoided and the vehicle remains stable when braking.

Electromechanical brake booster (eBB)

The electromechanical brake booster (eBB) supports the foot pressure only when the ignition is switched on and enhances the pressure applied to the brake pedal by the driver ⇒ . In case of braking support by a driver assistance system, such as during control by the ACC or during emergency braking, the brake pedal may move itself.

After switching off the ignition, braking assistance will be gradually reduced. If the vehicle is still being held by the brake pedal, text messages will appear on the instrument cluster display. Brake support is limited in this case.

Secure the stationary vehicle against rolling away → page , *Parking*.

WARNING

Driving without the brake booster or when the brake booster's functionality is limited can increase the braking distance significantly, increasing the risk of accidents and serious injury.

- Never stop the engine or switch the ignition off while the vehicle is moving.
- If the brake booster is not working, you will need to press the brake pedal harder because the lack of braking assistance will increase the braking distance.
- Always keep the footwell beneath the pedals clear so that the brake pedal is unobstructed and can move freely.

Switching the braking support system on and off

Driving situations

In order to avoid risks, the brake systems should not be switched off under normal conditions ⇒ .

WARNING

When ESC is switched off, the risk of the vehicle swerving is significantly higher. The vehicle can be difficult for inexperienced drivers to handle at high speeds. Accidents and serious injuries could result.

- Only switch off ESC if you are driving on a closed track and are experienced in sporty driving.
- Never take risks, and note the physical limits of the vehicle.

Switching on and off

1. Open the vehicle settings of the Infotainment system ⇒ *Vehicle settings menu*.
2. Open the settings for parking systems.
3. Select the function.

If the driving situation no longer exists, the brake system should be switched on again completely ⇒ .

ASR

It can be helpful to switch off ASR when the vehicle is driven on loose ground or when "rocking" the vehicle out of place because it is stuck ⇒ .



ASR manually switched off. The yellow indicator light turns on.

ESC Off

The function assists experienced drivers with sporty driving. The ESC is switched off and stabilizing interventions are not performed. Always read the safety instructions ⇒ .



ESC manually switched off. The yellow indicator light turns on.

Troubleshooting

BRAKE Electromechanical brake servo failure



Do not continue driving!

The red warning light turns on.

A message is displayed if necessary. Press the brake pedal harder, as the lack of braking assistance will increase the braking distance.

1. Contact an authorized Volkswagen dealer or authorized Volkswagen Service Facility for assistance.



Electromechanical brake servo faulty

The yellow indicator light turns on.

A message is displayed for a few seconds.

The brake pedal might pulse when pressed. Press the brake pedal harder, because the reduced braking assistance will increase the braking distance.

1. Contact an authorized Volkswagen dealer or authorized Volkswagen Service Facility. Volkswagen recommends contacting an authorized Volkswagen dealer or authorized Volkswagen Service Facility.

ABS ABS failure or malfunction

The yellow indicator light turns on.

1. Contact an authorized Volkswagen dealer or authorized Volkswagen Service Facility. Volkswagen recommends contacting an authorized Volkswagen dealer or authorized Volkswagen Service Facility.

The vehicle can be braked without ABS.

ESC malfunction

The yellow indicator light turns on. ESC has been switched off.

There is a fault or malfunction.

1. Switch the ignition off and on.
2. Drive a short distance at a speed of approximately 15 km/h (approx. 9 mph) to 20 km/h (approx. 12 mph).
3. If the  indicator light stays on, contact a suitably qualified professional. Volkswagen recommends contacting an authorized Volkswagen dealer or authorized Volkswagen Service Facility.

Noises in the braking assistance systems

When the braking assistance systems are actively regulating, the brake pedal may move or noises may occur.

1. Continue braking with the necessary force and, if necessary, steer the vehicle.

WARNING

If the **BRAKE** brake warning light comes on together with the **ABS** indicator light, the regulating function of the ABS could be malfunctioning. This could cause the rear wheels to lock relatively quickly when braking. Locked rear wheels can lead to loss of vehicle control.

- If possible, reduce your speed and drive slowly and carefully to the nearest authorized Volkswagen dealer or authorized Volkswagen Service Facility to have the brake system checked. Volkswagen recommends contacting an authorized Volkswagen dealer or authorized Volkswagen Service Facility.
- Avoid sudden braking or driving maneuvers.
- If the ABS indicator light does not turn off, or turns on during the journey, the ABS is not working correctly. The vehicle can only be stopped with the normal brakes (without ABS). The security provided by the ABS is not available. Visit an authorized Volkswagen dealer or authorized Volkswagen Service Facility as soon as possible. Volkswagen recommends contacting an authorized Volkswagen dealer or authorized Volkswagen Service Facility.

Practical equipment

Storage compartments

Introduction

WARNING

Loose objects can be thrown around the inside of the vehicle during sudden driving or braking maneuvers. This can cause serious injuries and loss of vehicle control.

- Store objects in only closed storage compartments.
- Always keep the storage compartments closed while driving.
- Only hang lightweight clothing, up to a maximum of 5.5 lbs (approximately 2.5 kg), from the coat hooks in the vehicle. Never leave heavy, hard or sharp objects in the pockets.

WARNING

An open glove compartment can increase the risk of serious injuries in the event of a collision or during sudden braking or driving maneuvers.

- Always keep the glove compartment closed while driving.

WARNING

Lighters in the vehicle can become damaged or ignite unintentionally. This can cause severe burns and vehicle damage.

- Before closing compartments or storage areas, always make sure that there are no cigarette lighters near the sections that will be closing.
- Never place lighters in compartments, in storage areas, or on other surfaces in the vehicle. Lighters may ignite as a result of high surface temperatures, especially in summer.

WARNING

Incorrect usage of the cup holders can cause injuries.

- Do not place hot beverages in the cup holders. Hot beverages in the cup holders could spill and cause burns while driving, during sudden braking maneuvers, or in collisions.
- Take care that only suitably sized drinks are stored in the cup holder. Drinks must always be steady and secure in the cup holder.

WARNING

Closed beverage bottles can explode from heat and burst from frost.

- Never leave closed beverage bottles in an extremely hot or extremely cold vehicle.

NOTICE

- Never leave any objects, groceries, or medications that are sensitive to temperature in the vehicle interior. Hot and cold conditions could damage these objects and make them unusable.
- Objects made out of transparent materials in the vehicle, for example transparent suction cups on the window glass, can concentrate sunlight and cause damage to the vehicle.

Sockets

Introduction

Electrical devices can be connected to the sockets in the vehicle.

The 12 V socket only works when the ignition is switched on.

WARNING

Using sockets and electrical devices incorrectly can cause fires and serious injuries.

- Never leave children unattended in the vehicle. Sockets and the devices connected to them can be used when the ignition is switched on.
- If the electrical devices become too warm, turn off the devices immediately and disconnect them.

NOTICE

- To reduce the risk of damage to the electrical system, never attempt to charge the 12 V vehicle battery by connecting electrical devices that provide power to the 12 V sockets, such as solar panels or battery chargers.
- Only use electrical devices that have been tested for compliance with the applicable directives for electromagnetic compatibility.
- Do not use any malfunctioning devices.
- To reduce the risk of damage from voltage fluctuations, turn electrical devices off before switching the ignition on or off and before starting the engine.
- Never connect electrical devices that draw more than the specified load of a 12 V socket. The vehicle electrical system can be damaged when the maximum load is exceeded.
- Refer to the operating instructions for the electrical devices.

The 12 V vehicle battery will drain if the ignition and electrical devices are switched on while the engine is switched off.

Unshielded devices can cause malfunctions in the radio, the Infotainment system and in the vehicle electronics, depending on the vehicle equipment.

Sockets in the vehicle

Please read the introductory information and heed the Warnings and Notice ⇒ and Introduction.

Do not exceed the maximum power of the sockets. The power draw of the external devices is indicated on their identification labels.

12 V socket



Fig. 133 In the lower part of the center armrest, in the rear center console or in the luggage compartment: Folding 12-volt socket (general example).

The total continuous output of all 12 V sockets in the vehicle is 120 watts ⇒ Introduction.

The maximum power of a 12 V socket in the vehicle with the engine running totals 180 watts.

NOTICE

Using 12 V sockets for too long at maximum power can cause the fuse to blow.

- Never use 12 V sockets at their maximum power for longer than 10 minutes.
- Only ever use a single 12 V socket at maximum power.

Data transmission

Cyber security

Cyber security describes measures that reduce the risk of illegal access to vehicle functions, data and control modules caused by malware or an Internet attack.

What are connectivity components?

Control modules for data transmission, interfaces, media and diagnostic connections are connectivity components, through which information and data can be exchanged between the vehicle and external devices or the Internet. The following connectivity components may not be available in all vehicles:

- Diagnostic connection port
- Control module with installed eSIM card.
- Mobile phone interface
- App-Connect.
- Wi-Fi hotspot.
- NFC radio technology.
- Bluetooth interface.
- USB port.
- SD card slot.
- SIM card slot.

Connectivity components are the key points for cyber security. Connectivity components are also equipped with security mechanisms that minimize the risk of unauthorized access to vehicle systems.

Security mechanisms

Software and security mechanisms available in the vehicle undergo continuous development. Similar to computers or operating systems on cell phones, software and security mechanisms in the vehicle may also be updated at various times.

Generally, system updates improve the security, stability, and processing speeds of the vehicle systems in vehicles that have already been produced.

WARNING

In spite of the integrated security mechanisms, malware can cause malfunctions in control modules and vehicle functions. This can cause serious accidents and fatal injuries.

- If the vehicle works or reacts differently to normal, reduce your speed in a controlled manner.
- Contact suitably qualified professionals for assistance. Volkswagen recommends contacting an authorized Volkswagen dealer or authorized Volkswagen Service Facility.

 Malware can also access data and information that are stored in the control modules, in the Infotainment system, on connected data carriers, and in paired cell phones.

Minimizing risks

You can actively help to reduce the risk of unauthorized access to vehicle systems and functions by following these guidelines:

- Only use data carriers, Bluetooth devices and cell phones in the vehicle that do not contain any manipulated data or malware.
- Only have the vehicle repaired and serviced by suitably qualified professionals. Volkswagen recommends contacting an authorized Volkswagen dealer or authorized Volkswagen Service Facility.

WARNING

Computers, data carriers and cell phones that are connected to the Internet or are used in public or private networks can be infected by manipulated data and malware.

- Protect computers, data carriers and cell phones with a suitable antivirus program and by taking generally recognized precautions.
- Regularly update the antivirus program using the provided system updates or upgrades provided by the vendor.

Wired and wireless connections

Introduction

Some external devices can be connected to the Infotainment system using the wired and wireless connections in the vehicle, if available.

The type and quantity of wired and wireless connections depend on the vehicle equipment and country. The connections may differ within a model line or in a mode with optional equipment.

In wired connections, only use the original connecting cable that belongs to the device or the connecting cable that was placed in the vehicle at the factory, if available.

If the plug on the connector cable cannot be inserted, check the position and the connections.

NOTICE

Only use a suitable and undamaged connector cable for wired connections.

- Hold the plug on the connector cable in the correct position and insert it into the intended socket while pressing lightly. Pressing strongly can damage the device connection and the plug on the connector cable.
- The connector cable must not be pinched or bent sharply.
- Using unsuitable or damaged connector cables can cause malfunctions and damage to the device.

If a connected device is not recognized, disconnect all connected devices and then reconnect the device. Check the function of the connecting cable, if necessary.

If malfunctions occur in a connected device, restart the device. This sometimes fixes the error.

USB port

Please read the introductory information and heed the Warnings and Notice ⇒ [Introduction](#).

Using the USB port, you can transfer data and charge devices or only charge devices.

USB-C port



Fig. 134 USB-C connection in the vehicle (general example).

The vehicle may contain the following USB-C ports:

☛ Symbol for a USB port for data transmission and charging. ☛ Symbol for a USB port for charging only.

Possible USB port installation locations

The number and installation locations of USB ports depend on the vehicle and vehicle equipment and are not available in all countries.

- In the center console.
- At the base of the interior rearview mirror.
- In the storage compartment in the center console.
- In the compartment underneath the center armrest.

USB ports at the rear seats only come with a charging function.

Available Data Transfer Functions

The following USB data transfer functions are available depending on the vehicle equipment.

- App-Connect ⇒ *App-Connect*.
- Media playback ⇒ *Media mode*.
- Update, e.g. of the navigation data ⇒ *Navigation data*.

Available Charging Power

Voltages up to 20 V are provided via the USB port, which enables up to 45 W charging power.

Depending on the vehicle equipment, the following charging profiles may be supported by the USB ports:

- Legacy charging (2.5 W).
- BC1.2 (7.5 W).
- USB-C charging (15 W).
- USB power delivery (up to 45 W).

The actual charging power of the connected device depends on the following aspects:

- Supported charging profiles.
- Device charge level.
- Device temperature.
- Charging cable used.

 For double USB ports, the charging power can be split between both ports.

Instructions and restrictions

- Only use suitable USB connection cables. The USB connection cable must match the USB port installed in the vehicle.
- Dirty, overheated or damaged data carriers are not to be used. Read and heed the information provided by the manufacturer.
- Difference in quality between data carriers from different manufacturers can cause problems with media playback.
- Using USB extension cables, USB adapters or USB hubs may result in malfunctions or failure of the USB functions.

Bluetooth® interface

 Please read the introductory information and heed the Warnings and Notice ⇒  *Introduction*.

The Bluetooth interface is a wireless connection.

In Bluetooth audio mode, audio files that are on a Bluetooth audio source that is connected via Bluetooth, such as a cell phone, can be played through the vehicle speakers.

Bluetooth audio mode is only possible in vehicles equipped with a factory-installed mobile phone interface that supports this function.

Bluetooth profiles

The Infotainment system is equipped with a Bluetooth interface at the factory.

A maximum of three Bluetooth devices can be connected at the same time.

The following Bluetooth profiles may be available in the specified version or in another version:

- HFP 1.7.
 - Telephony and handsfree mode.
- A2DP 1.3.
 - Music playback.
- AVRCP 1.6.
 - Display and operation for music playback.
 - Transfer of cover art.
- PBAP 1.2.
 - Access to phone book and call lists.
- MAP 1.4.
 - Access to SMS and e-mail.
- SPP 1.2.
 - Serial data transfer via Bluetooth.

Starting Bluetooth audio

Requirements

- ✓ The Bluetooth audio source is paired with and connected to the Infotainment system ⇒ *Coupling, connecting and managing*.

✓ The Bluetooth audio source supports the A2DP Bluetooth profile.

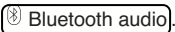
1. Lower the volume on the Infotainment system.
2. Activate Bluetooth visibility on the external Bluetooth audio source, such as a cell phone.
3. Open the Media menu.
4. Tap  and select .
5. If necessary, start playback on the Bluetooth audio source manually.

When playback from the Bluetooth audio source is finished, the Infotainment system remains in Bluetooth audio mode.

Controlling playback

The extent that the Bluetooth audio source can be controlled by the Infotainment system depends on the type of Bluetooth audio source that is connected.

For media players that support the AVRCP Bluetooth profile, playback from the Bluetooth audio source can be started or stopped automatically when Bluetooth audio mode or another audio source is selected. Depending on the Bluetooth audio source, it may also be possible to display and play the track on the Infotainment system.

 **Because of the large number of possible Bluetooth audio sources, it is not possible to guarantee that all functions described can be performed correctly.**

 **On a connected Bluetooth audio source, all warning and operation tones, such as touch tones on a cell phone, should generally be switched off to avoid interference and malfunctions.**

 **Depending on the device, if an external media player is connected to the Infotainment system via Bluetooth and the USB port  at the same time, the Bluetooth audio connection may be automatically disconnected.**

Connecting an external audio source via Wi-Fi

 **Please read the introductory information and heed the Warnings and Notice ⇒  Introduction.**

The Wi-Fi connection is a wireless connection.





In Wi-Fi audio mode, sources such as cell phones that are connected via Wi-Fi can be used for audio streaming.



The availability of the Wi-Fi function depends on the country and the Infotainment system being used.

Requirements

- ✓ The connected audio source has a suitable app or supports media sharing using the UPnP standard.
- ✓ There must be a Wi-Fi connection to the audio source.

Starting Wi-Fi audio streaming

1. Lower the volume on the Infotainment system.
2. To open the Media main menu, tap  .
3. Start the UPnP server application or a suitable app for audio playback on the Wi-Fi audio source.
4. Tap  and select .
5. Follow the instructions shown on the Infotainment system screen and on the Wi-Fi audio source screen.

The function key for selecting the audio source  in the Media main menu can vary if another audio source is connected with the Infotainment system, e.g. by USB , and is selected.

Controlling playback

The extent to which the Wi-Fi audio source can be controlled by the Infotainment system depends on the type of Wi-Fi audio source that is connected.

Wi-Fi hotspot

Introduction

The "Wi-Fi hotspot" function is not available in all countries and vehicles.

Some Infotainment systems can be used as a Wi-Fi hotspot for Internet access on up to eight Wi-Fi devices.

Some Infotainment systems can use the Wi-Fi hotspot on an external Wi-Fi device (Wi-Fi client) ⇒ [Setting up a Wi-Fi client](#).

A data connection is required for connecting to the Internet and for certain functions, such as using VW Car-Net.

 **The Wi-Fi connection is encrypted by default with WPA2 encryption for security reasons. Volkswagen recommends always using WPA2 encryption. Observe legal regulations for the country where you are operating the vehicle.**

 **There may be fees for the required data connection. Volkswagen recommends using a mobile phone plan with a flat rate data package due to the possible volume of data. Information on this can be obtained from the mobile network provider.**

 **Depending on your mobile data rate, additional costs, such as roaming fees, may result from downloading and using data plans online, especially in other countries.**

 When crossing the border into countries with different permitted radio frequencies than your own country, use of the wireless function/the Wi-Fi must be deactivated to comply with legal provisions. The wired functions are not affected by this restriction and can still be used.

Opening the Wi-Fi settings

1. Tap **(HOME)** ►  ► Wi-Fi.

2. Make corresponding entries or tap function keys.

Changes will be automatically applied when the menu is closed.

Setting options

- Setting up the Infotainment system as a Wi-Fi hotspot.
- Connecting to the Infotainment system via a quick connection.
- Connecting with the Wi-Fi.

Establishing a data connection

Wi-Fi (9.2" version and 8" version)

- Wi-Fi in accordance with IEEE 802.11 b/g/n.
- 2.4 GHz and 5 GHz data transfer.
- Two Wi-Fi modes at once:
 - Tethering (2.4 GHz).
 - 2.4 GHz access point.
- Up to eight Wi-Fi devices can be connected at the same time.
- Internet connection via Wi-Fi:
 - Tethering via cell phone.
 - Hotspot for clients in the vehicle.
- Apple CarPlay™ via Wi-Fi.
- Android Auto™ via Wi-Fi.
- Simplified pairing process via WPS, NFC or QR code .

Possible data connection types

eSIM (embedded SIM): The vehicle has a control module with installed eSIM card (eSIM). In order to use the Wi-Fi hotspot, you need to purchase data plans via the In-Car Shop or via the online shop of our mobile communications partner.

External Wi-Fi device: Use the Wi-Fi hotspot on an external cell phone ⇒ [Setting up a Wi-Fi client](#).

The types of possible data connections depend on the country and equipment.

Setting up and deactivating a Wi-Fi hotspot

The Infotainment system can be used as a Wi-Fi hotspot for Internet access on up to four Wi-Fi devices.

To connect to the Internet and, for instance, to be able to use VW Car-Net, a data connection is additionally required, for example via an internal eSIM card, a CarStick or an external Wi-Fi device. The possible types of data connections depend on the country and the Infotainment system being used.

Determining network information

Requirements

- ✓ Your vehicle has been added to your VW Car-Net user account.
- ✓ You have paid for a data plan for your vehicle.

1. Log in to your user account via the VW Car-Net app or the VW Car-Net portal and select the vehicle.
2. Search for the network name (SSID) and select the network key (password) for the vehicle as follows:
 - In the portal, under User ► Wi-Fi SSID and password.
 - Or: in the app, under User ► Wi-Fi ► SSID & password.

Connecting to Wi-Fi

1. Tap **(MENU)** ► **Setup**  ► **(Wi-Fi)** ► **(Mobile hotspot)**.
2. Activate the **Mobile hotspot** checkbox.
3. Search for available networks on the Wi-Fi device.
4. Select from the network names (SSID).

5. Enter the network key on the Wi-Fi device and confirm it.

The Wi-Fi connection will be established. If necessary, you may need to enter additional information on the Wi-Fi device.

6. Repeat the process to connect additional Wi-Fi devices.

Deactivating a Wi-Fi hotspot

1. Open the Hotspot settings (Wi-Fi) menu. To do this, tap **(MENU)** ► **Settings**  ► **(Wi-Fi)** ► **(Mobile hotspot)**.
2. Deactivate the **Mobile hotspot** checkbox.

The Wi-Fi hotspot is deactivated.

Setting up a Wi-Fi client

The Infotainment system can use the Wi-Fi hotspot of an external Wi-Fi device, e.g. of a cell phone, to connect to the Internet and use mobile online services.

Connecting to Wi-Fi

1. Activate the Wi-Fi hotspot on the Wi-Fi device. Refer to the manufacturer's operating instructions.
2. Tap **(MENU)** ►  ► **(Wi-Fi)** ► **(Wi-Fi)**.
3. Activate the **Wi-Fi** checkbox.

The Infotainment system scans for Wi-Fi hotspots in the area. This scan process can take a few seconds.

4. Select the Wi-Fi network of the preferred Wi-Fi device.
5. Enter the Wi-Fi hotspot network key on the Infotainment system and confirm with **(OK)**.

The Wi-Fi connection will be established. If necessary, you may need to enter additional information on the Wi-Fi device.

 **Due to the large number of Wi-Fi devices that are available, there is no guarantee that all functions will always be available.**

 **The Wi-Fi function may not be available in all countries and may vary.**

Quick connection

Quick connection makes it possible to easily and quickly set up a wireless local network with encryption. In several countries, the function can alternatively be executed by scanning in a QR code.

WPS with the Infotainment system as a Wi-Fi hotspot

Requirements

- ✓ The Wi-Fi hotspot of the Infotainment system is activated.
- ✓ The Wi-Fi device supports WPS.

1. Tap **(MENU)** ►  ► **Wi-Fi**.
2. Tap Quick connection with Infotainment system.
3. Activate WPS on the external Wi-Fi device to be connected.

The Wi-Fi connection will be established. If necessary, you may need to enter additional information on the Wi-Fi device.

4. Repeat the process to connect additional Wi-Fi devices.

Only one WPS connection can be established at a time. If multiple connection attempts start at the same time, all connection attempts will fail.

WPS with Infotainment system as client

Requirements

- ✓ The Wi-Fi hotspot of the Infotainment system must be deactivated.
- ✓ The Wi-Fi device must support WPS.

1. Tap **(MENU)** ►  ► **Wi-Fi** ► **Wi-Fi**.
2. Tap WPS quick connection (WPS button).
3. Activate WPS on the external Wi-Fi device.

The Wi-Fi connection will be established. If necessary, you may need to enter additional information on the Wi-Fi device.

 **WPS is not supported by all Wi-Fi devices. In this case, connect manually:**

- Setting up the Infotainment system as a Wi-Fi hotspot ⇒ *Wi-Fi hotspot*, ⇒ *Setting up and deactivating a Wi-Fi hotspot*.
- Connecting the Infotainment system as client to the hotspot of an external Wi-Fi device ⇒ *Setting up a Wi-Fi client*.

Setting up a Wi-Fi connection via NFC

The Wi-Fi connection can be established via NFC using the shelf of the cordless charging function.

Requirements

- ✓ The rear shelf for the wireless charging function is installed in the vehicle.
- ✓ NFC is activated on the Wi-Fi device.
- ✓ The Wi-Fi hotspot of the Infotainment system is activated.

1. Tap **(MENU)** ►  ► Wi-Fi.
2. Tap Quick connection with Infotainment system.
3. Unlock the Wi-Fi device and place on the rear shelf for the wireless charging function ⇒ *Wireless charging function*.

The Wi-Fi device is connected as client to the Wi-Fi hotspot of the Infotainment system.

 **The wireless charging function is deactivated while the Infotainment system is in the Wi-Fi settings menu. Wireless charging is reactivated if you leave the settings menu.**

 **On older Wi-Fi devices, the functionality may be restricted or not work at all. Ensure that you always use the latest software version for your Wi-Fi device.**

Setting up a Wi-Fi connection via QR code

The Wi-Fi connection can also be established by scanning the corresponding QR code.

Requirements

- ✓ The Wi-Fi hotspot of the Infotainment system is activated.
- ✓ A suitable application for scanning QR codes is installed on the Wi-Fi device.

1. Tap **(MENU)** ►  ► Wi-Fi.
2. Tap Quick connection with Infotainment system.
3. Scan the QR code on the screen of the Infotainment system with the Wi-Fi device.

The Wi-Fi device is connected as client to the Wi-Fi hotspot of the Infotainment system.

App-Connect

Introduction

App-Connect makes it possible to display and control content and functions displayed on the cell phone through the Infotainment system screen.

To do this, the cell phone must be connected to the Infotainment system via a USB interface with a data transfer function.

Some technologies can also be used with App-Connect Wireless via the Bluetooth interface and a Wi-Fi connection.

The following technologies may be available:

- Apple CarPlay™.
- Apple CarPlay™ Wireless.
- Android Auto™.
- Android Auto™ Wireless.
- MirrorLink®.

Which App-Connect technologies are available to you depends on the country and on the cell phone in use.

MirrorLink, Apple CarPlay and Android Auto are technologies which are operated by third parties and provided by Volkswagen. Volkswagen is not responsible if these technologies are canceled, discontinued or deactivated during the service life of the vehicle.

You can find more information on the Volkswagen website.

App-Connect wireless function in the event of border crossings

In the event of border crossings into countries with different permissible radio frequencies than your own country, please note the following:

- The App-Connect wireless function may be limited due to legal provisions, or may not be possible at all. This can be indicated by a message in the Infotainment system.
- The App-Connect wireless function must be deactivated due to legal provisions. The Wi-Fi hotspot must be deactivated.

This does not apply to wired functions.

Opening the App-Connect main menu

Navigation to the App-Connect main menu depends on the Infotainment system being used.

1. Tap **(HOME)** ► .

Or: press **(APP)**.

Setting up App-Connect Wireless

In order to use App-Connect Wireless, first pair the cell phone with the Infotainment system.

Connecting a cell phone for the first time

1. Unlock the cell phone.
2. Activate Wi-Fi reception and Bluetooth on the cell phone.
3. Connect the cell phone to the Infotainment system via a USB cable or Bluetooth.
4. Open the App-Connect main menu if it does not open automatically.
5. Select the cell phone and your preferred technology.
6. Allow the Infotainment system the required access. To do this, confirm authorization requests on the cell phone.
7. Disconnect the USB connection and re-connect with the Infotainment system using Wi-Fi or Bluetooth.

App-Connect Wireless set-up is complete.

Pairing is complete. The paired cell phone can now use App-Connect Wireless in the future without a USB connection.

If any pop-up menus were dismissed during the connection process, App-Connect Wireless will not be available. In this case, Volkswagen recommends deleting the devices from the cell phone settings and Infotainment system and restarting the connection process.

 **App-Connect Wireless may not be supported by all technologies.**

WARNING

Using apps while driving can distract from traffic. Driver distraction can cause accidents and injuries.

- Always drive attentively and responsibly.
- Only use apps and functions when the vehicle is stationary.

WARNING

If apps are used that are not suitable or that are not used correctly, this may result in vehicle damage, accidents, and serious injuries.

- Protect the cell phone and its apps from misuse.

NOTICE

Volkswagen is not responsible for vehicle damage that is caused by low-quality or malfunctioning apps, inadequate programming of apps, insufficient network strength, data loss during transmission, or misuse of cell phones.

Apps

 **Please read the introductory information and heed the Warnings and Notice ⇒  and  Introduction.**

Content from Volkswagen apps and third party provider apps displayed on cell phones can be displayed on the Infotainment system screen using Volkswagen App-Connect.

Apps from third-party providers may be incompatible.

The use of apps and the required mobile phone connection may be subject to additional charges.



Apps can be based on many different designs and can also differ depending on the vehicle and country. The content, scope, and providers of the apps may vary. Furthermore, some apps depend on the availability of services from third party providers.

It cannot be guaranteed that the apps that are offered will be able to run on all cell phones and with all operating systems.





The apps provided by Volkswagen can also be changed, canceled, deactivated, reactivated, and enhanced without notice.

To avoid driver distraction, only certified apps can be used while driving.

Symbols and settings for App-Connect

 **Please read the introductory information and heed the Warnings and Notice ⇒  and  Introduction.**
Symbols in the App-Connect menu

The symbols present depend on the type of Infotainment system and the vehicle model.

 Show further information.  Open the App-Connect settings menu.  Open the App-Connect settings menu.  Select the Apple CarPlay technology.
 Select the Android Auto technology.  Select the MirrorLink technology.

Setting options in the App-Connect settings menu

The setting options depend on the integrated Infotainment system.

Mobile devices: Open the device manager.

✓ **Activate data transmission for VW apps:** Data transmission for VW apps is activated.

✓ **Allow MirrorLink messages to display:** Messages are displayed when using MirrorLink.

Apple CarPlay™

📖 Please read the introductory information and heed the Warnings and Notice ⇒ ⚠️ and ⓘ Introduction.

Requirements

The following requirements must be met in order to use Apple CarPlay:

- ✓ The iPhone must support Apple CarPlay.
- ✓ Voice control (Siri) must be activated on the iPhone.
- ✓ Apple CarPlay must be activated in the iPhone settings without restrictions.
- ✓ The iPhone must be connected to the Infotainment system with a USB connection. Only USB ports with data transfer are suitable for use with Apple CarPlay.
- ✓ The USB cable being used must be an original cable from Apple.

Apple CarPlay Wireless: Bluetooth and Wi-Fi must also be activated on the iPhone.

📍 These technologies may not be available in all countries.



📍 Information on technical requirements, compatible iPhones, certified apps and availability can be found at the Volkswagen and Apple CarPlay website or at an authorized Volkswagen dealer or authorized Volkswagen Service Facility.

Connecting



When connecting an iPhone for the first time, follow the instructions on the Infotainment system screen and the iPhone display.

The requirements must be met in order to use Apple CarPlay.

Start Apple CarPlay:

1. To open the App-Connect main menu, tap **(MENU)** ▶ App-Connect .
Or: press (APP).
2. To connect to the iPhone, tap  Apple CarPlay.

Disconnecting

1. To open the App-Connect main menu, tap  in Apple CarPlay mode.
2. To end the active connection, tap  or .

The presentation of the function keys in the display may vary.



Special conditions

During an active connection with Apple CarPlay, the following conditions apply:

- Bluetooth connections between the iPhone and the Infotainment system are not possible.
- If there is an active Bluetooth connection, it will be automatically ended.
- Phone functions are only possible via Apple CarPlay. The functions described for the Infotainment system are not available.
- The connected iPhone cannot be used as a media device in the Media main menu.
- It is not possible to use the internal navigation and Apple CarPlay navigation at the same time. The route guidance which was started last ends the previous active one.
- Depending on your Infotainment system, you can view information about telephone operation in the instrument cluster display.
- Depending on your Infotainment system and the navigation app used, you can view upcoming turns in the instrument cluster display.
- You can accept or decline incoming calls or end a call in progress using the buttons on the multi-function steering wheel.

Voice control

The “voice control” function depends on the vehicle equipment.

1. Tap  briefly to start the Infotainment system voice control.
Or: to start voice control (Siri) on the connected iPhone, tap and hold .

Android Auto™

📖 Please read the introductory information and heed the Warnings and Notice ⇒ ⚠️ and ⓘ Introduction.

Requirements

- ✓ The cell phone – hereafter referred to as a smartphone – must support Android Auto.
- ✓ An Android Auto app must be installed on the smartphone.

- ✓ If Android Auto Wireless cannot be used, the smartphone must be connected to the Infotainment system with a USB connection that allows data transfer.
- ✓ The USB cable used must be an original cable from your mobile device manufacturer.

Android Auto Wireless: Bluetooth and Wi-Fi must also be activated on the smartphone.



 **These technologies may not be available in all countries.**

 **Information on technical requirements, compatible smartphones, certified apps and availability can be found on the Volkswagen and Android Auto websites or at an authorized Volkswagen dealer or authorized Volkswagen Service Facility.**



Connecting

When connecting a smartphone for the first time, follow the instructions on the Infotainment system screen and the smartphone display.

The requirements must be met in order to use Android Auto.

1. Tap  to open the App-Connect main menu.
Or: press .
2. Tap  Android Auto to establish the connection with the smartphone.

Disconnecting

1. To open the App-Connect main menu, tap Close  in Android Auto mode.
2. Tap  to end the active connection.



Special conditions

During an active connection with Android Auto, the following conditions apply:

- An active Android Auto device can also be connected with the Infotainment system via Bluetooth (HFP profile) at the same time.
- Phone functions are possible through Android Auto. The Infotainment system phone function can also be used if the Android Auto device is connected to the Infotainment system via Bluetooth at the same time.
- An active Android Auto device cannot be used as a media device in the Media main menu.
- It is not possible to use the internal navigation and Android Auto navigation at the same time. The route guidance which was started last ends the previous active one.
- You can view information about telephone operation in the instrument cluster display.
- Depending on your Infotainment system and the navigation app used, you can view upcoming turns in the instrument cluster display.
- You can accept or decline incoming calls or end a call in progress using the buttons on the multi-function steering wheel.

Voice control





The “voice control” function depends on the vehicle equipment.

1. Tap  briefly to start the Infotainment system voice control.
Or: Tap and hold the  button to start voice control of the connected smartphone.

MirrorLink®

 Please read the introductory information and heed the Warnings and Notice  and  Introduction.

Function keys

 Returns to the App-Connect main menu. Here you can end the MirrorLink connection, connect another cell phone, or select another technology.  Tap to close apps that are open. Then tap the apps to be closed or tap the Close all function to close all open apps.  Tap to display the cell phone on the Infotainment system screen.  Open the MirrorLink settings.  Tap to return to the MirrorLink main menu.

Requirements



- ✓ The cell phone must support MirrorLink.
- ✓ The cell phone must be connected to the Infotainment system via a USB connection with data transfer.
- ✓ The USB cable used must be an original cable from your cell phone manufacturer.
- ✓ Depending on the cell phone in use, an appropriate Car Mode app must be installed on the device to use MirrorLink.

 **Information about technical requirements, compatible cell phones, certified apps and availability can be found via the Volkswagen and MirrorLink website or at your authorized Volkswagen dealer or authorized Volkswagen Service Facility.**

Connecting

When connecting a cell phone for the first time, follow the instructions on the Infotainment system screen and the cell phone display.

The requirements must be met in order to use MirrorLink.

1. To open the App-Connect main menu, tap  App-Connect .

Or: press .

2. Tap  to connect to your cell phone.

Disconnecting

1. To open the App-Connect main menu, tap the  button in MirrorLink mode.

Or: To get to the MirrorLink main menu, tap .

2. Tap  to end the active connection.

Special conditions

When there is an active connection with MirrorLink, the following conditions apply:

- An active MirrorLink device can also be connected with the Infotainment system at the same time via Bluetooth.
- If the MirrorLink device is connected to the Infotainment system via Bluetooth, you can use the Infotainment system phone function.
- An active MirrorLink device cannot be used as a media device in the Media main menu.
- You can view information about telephone operation in the instrument cluster display.
- The instrument cluster display will not show upcoming turns or display information about media mode.
- You can accept or decline incoming calls or end a call in progress using the buttons on the multi-function steering wheel.

Mobile online services

myVW with Connected Features by Car-Net®

Introduction

VW Car-Net Ready

Your vehicle is equipped with VW Car-Net hardware, including a three-button module in the roof console. In order to use the VW Car-Net services, you need a subscription to them and to activate them. Many of the services come at an additional cost. Some services may be offered as a trial subscription for a limited period of time.

VW Car-Net requires a mobile network connection and GPS signal availability.

WARNING

Using apps while driving can distract from traffic. Driver distraction can cause accidents and injuries.

- Always drive attentively and responsibly.
- Only use apps and functions when the vehicle is stationary.

 **Once you have registered with VW Car-Net, positional information from the vehicle is transmitted every time one of the VW Car-Net buttons is tapped. This also occurs in the event of an automatic emergency call or periodically in conjunction with using the VW Car-Net functions. Volkswagen has the capability to determine the exact position of the vehicle at any time, should this be required legally, by order or compulsory measure, or be necessary in emergencies, provided that the VW Car-Net equipment has not been deactivated. For further information, please contact the VW Car-Net Response Center on 1-833-648-2735. Calls may be monitored or recorded.**

 **Volkswagen collects, processes, shares and transmits information about you and your vehicle in compliance with the VW Car-Net terms and conditions and privacy provisions. For more information, please visit our website at www.vw.com/carnet.**

Situations that can affect system functions

 **Please read the introductory information and heed the Warnings and Notice** ⇒  **Introduction.**

Even if requirements for the usage of these services have been met, the performance of VW Car-Net may be impaired or blocked by various factors that are outside of the control of Volkswagen. In particular, this includes:

- Maintenance, repairs, deactivations, software updates, and technical improvements to the telecommunications systems, satellites, servers, and databases.
- Switching the mobile network standard to transmit mobile data through the telecommunications provider, for example, from UMTS to EDGE or GPRS.
- Switching off an existing mobile network standard via the telecommunications provider.
- Malfunction, impairment, or interruption of the mobile network and GPS reception, for example due to high speeds, solar storms, weather conditions, regional circumstances, malfunctioning equipment, and high mobile network usage in the applicable radio cells.
- If you are in a location with no or very poor cell phone or GPS reception. These locations may include tunnels, areas between tall buildings, garages, parking ramps, underpasses, mountains, and valleys.
- Limited availability of information or incomplete or incorrect information from third-party providers, such as on map displays.
- In countries, federal states and regions where VW Car-Net not offered.

VW Car-Net® Portfolio

 **Please read the introductory information and heed the Warnings and Notice** ⇒  **Introduction.**

VW Car-Net is part of Connected Vehicle Services and makes driving a Volkswagen more convenient. The In-Vehicle Services can be used via the control for voice services in the roof console.

Emergency Call Service

If you or your passengers require medical assistance or help from the police, press the emergency call button. You will be connected to a contact partner at the Volkswagen emergency call center, who will assess your situation and, if required, will send the police or medical help to the GPS location of your vehicle.

 **Only press the emergency call button if you require medical assistance or help from the police via VW Car-Net.**

 **Volkswagen is not responsible for the reaction time of police or medical emergency services, or the assistance they provide on site.**

Roadside assistance call

In the event of a breakdown, press the roadside assistance call button. You will be connected to a contact partner at VW Roadside Call Assist, who will send help to your GPS location.

 **Do not use the roadside assistance call button or the information call button to request police or medical help.**

Information call

Press the information call button. You will be connected to a contact partner at the VW Car-Net call center, who can help you in the following cases, amongst others:

- Logging in and registering services.
- Finding and sending routes to the navigation system.
- Locating VW service partners.

Registration required

If you want to use VW Car-Net, you must log in and activate the functions. Many functions require a paid subscription. Some functions can be provided with a time-limited trial subscription. For more information on VW Car-Net functions, visit our website at www.vw.com/carnet.

After registering successfully, inform all users of the vehicle that the following data from the vehicle is sent or automatically received:

- Speed
- Location.
- Further information.

Functions and services of VW Car-Net and every trial or paid subscription may be adjusted, ended, deactivated, reactivated or enhanced without additional notifications. Visit www.vw.com/carnet for details regarding subscription, Terms of Use and privacy policy.

If you have any questions or would like to start a subscription, contact our VW Car-Net Response Center on 1-833-648-2735, or visit our website at www.vw.com/carnet.

Infotainment system

First steps

Introduction

The functions and settings of the Infotainment system depend on the vehicle equipment and are not available in all countries.

Prior to the first use

Before using the Infotainment system for the first time, read the following points to be able to fully use the available functions and settings:

- Observe the safety instructions ⇒ [Safety instructions](#).
- Reset the Infotainment system to factory settings.
- Find your favorite radio stations and save them on the station preset buttons to quickly access them ⇒ [Radio mode](#).
- Only use suitable audio sources and data carriers ⇒ [Media mode](#).
- Use current map data for the navigation system.
- Pair a cell phone in order to use the phone interface to make calls ⇒ [Mobile phone interface](#).
- Register on VW Car-Net® to use related services.

Other applicable documents

In addition to this manual, please refer to the following documentation when using this Infotainment system and its components:

- Supplements to your Owner's Manual.
- Operating instructions for the cell phone or audio sources.
- Operating instructions for external data carriers and players.
- Instructions for retrofitted or additional Infotainment accessories.
- Service description when using VW Car-Net services.

Safety instructions

 Refer to ⇒  and .

- Some functions may contain links to websites that are administered by third parties. Volkswagen does not assume ownership of third-party sites reached through links and is not responsible for their content.
- Some functions may contain third-party information that originates from third-party providers. Volkswagen is not responsible for the accuracy, currentness, and completeness of this non-proprietary information, and for ensuring that the rights of third parties are not violated.
- The radio stations and owners of the data carriers and audio sources are responsible for the transmitted content.
- Parking buildings, garages, underpasses, tunnels, tall buildings, mountains and valleys or electrical devices such as battery chargers can also interfere with cell phone, GPS and radio signal reception.
- Foil stickers or stickers with a metal layer placed on the antenna and on the windows can impair radio reception.
- Read and follow the applicable manufacturer's operating instructions when using cell phones, data carriers, external devices, and external audio and media sources.

WARNING

The Infotainment system's central processor is networked with the control modules installed in the vehicle. As a result, if the central processor is incorrectly repaired, removed or reinstalled, there is an increased risk of accident and injury.

- Never replace the central processor with a used central processor from a scrap vehicle or from recycling.
- Always have the central processor repaired, removed and reinstalled by suitably qualified professionals. Volkswagen recommends contacting an authorized Volkswagen dealer or authorized Volkswagen Service Facility.

WARNING

Driver distraction can cause accidents and injuries. Reading information on the screen, operating the Infotainment system and connecting, inserting or removing a data carrier or audio source while driving can distract from traffic and cause accidents.

- Always drive attentively and responsibly.

WARNING

Displays and information on the screen may be difficult to read if the lighting conditions are unfavorable or if the screen is damaged or dirty.

- Never allow displays and information on the screen to cause you to engage in behavior that poses a safety risk. Always drive attentively and responsibly.

WARNING

Setting the volume too high prevents warning chimes from being heard from outside and can cause hearing damage. This is true even if you are exposed to a loud volume for only a short time.

- Adjust the volume settings in the Infotainment system so that audible signals from outside the vehicle (such as sirens on emergency service vehicles) can still be heard.

WARNING

Sudden volume fluctuations may occur when the audio or media source is changed or connected.

- Reduce the volume level before changing or connecting an audio or media source.

WARNING

The following conditions may prevent or cause interruptions to emergency calls, phone calls, and data transmission:

- If you are in a location with no or very poor cell phone or GPS reception.
- If you are in a location where there is good cell phone and GPS reception, but the telecommunications provider's mobile communications network is malfunctioning or unavailable.
- If the vehicle components required for emergency calls, phone calls, and data transmission are damaged, not operating, or have insufficient power.
- If the cell phone battery is drained or if the battery charge level is too low.

WARNING

Radio stations can broadcast messages about disasters and dangers. It may not be possible to receive or send messages under the following conditions:

- If you are in a location with no radio reception, or insufficient reception.
- If the radio station's frequency bands are malfunctioning or not available.
- If the speakers and vehicle components required for radio reception are damaged, not operating, or have insufficient power.

WARNING

In some countries and mobile networks, emergency calls can only be made under the following conditions:

- A cell phone with an unlocked SIM card and sufficient calling credit is connected to the vehicle's phone interface.
- Adequate network coverage is available.

WARNING

Using a cell phone or CB radio inside the vehicle without a separate outside antenna that is installed correctly may create electromagnetic energy that exceeds permissible limits. This may be dangerous to your health and that of your vehicle occupants. This also applies if the exterior antenna is not installed correctly.

- Keep the cell phone antenna at least approximately 20 cm (8 inches) away from any active medical implants, such as pacemakers, because cell phones can impair the function of active medical implants.
- Do not place a cell phone that is turned on directly above or in the immediate vicinity of any active medical implants, for example by keeping the cell phone in a shirt pocket.
- Immediately switch off cell phones if you suspect there is interference with an active medical implant or other medical device.

WARNING

Unsecured or incorrectly mounted cell phones, external devices, and accessories can be thrown through the vehicle interior and cause injury in the event of sudden driving or braking maneuvers or a collision.

- Secure cell phones, external devices and accessories outside of the airbag deployment zone or stow them securely.
- Arrange cables for external devices and audio sources so that they are not in the way of the driver.

WARNING

Driving recommendations and traffic signs displayed in the navigation system may differ from the actual traffic situation.

- Traffic signs, signal systems, and traffic regulations take priority over the driving recommendations and displays in the navigation system.
- Adapt your speed and driving style to the visibility, weather, road and traffic conditions.
- Certain events, such as road closures, can considerably increase the original estimated driving time and distance to the destination, or navigation there may be temporarily impossible.

NOTICE

Radiation from cell phones that are switched on can interfere with sensitive technical and medical devices, potentially causing malfunctions or damage to the devices.

- Always switch off the cell phone in areas with special regulations relating to or prohibiting the use of cell phones.

NOTICE

Setting the volume too high and excessively loud or distorted playback can damage the speakers.

- Select the volume setting so that the speakers are not damaged.

User information

 Refer to  and  *Safety instructions*.

- The Infotainment system requires a few seconds to perform a complete system start, and will not respond to inputs during that time. During the system start, only the Rear Assist camera can be displayed.
- The Infotainment system must start completely before all displays can appear and functions can be performed. The length of time that it takes for the system to start depends on the scope of functions in the Infotainment system, and it can take longer to start at low and high temperatures.
- Observe local regulations and legal requirements when using the Infotainment system and corresponding accessories, such as a headset or headphones.
- For the Infotainment system to function, it must be switched on and the vehicle must be set to the current date and time if necessary.
- A missing function key in the screen is not the result of a device error, but instead corresponds to the country-dependent equipment.
- Some Infotainment system functions can only be selected when the vehicle is stationary. In some countries, the selector lever must also be in the P or N position. This is not a malfunction, but rather compliance with legal regulations.
- Some countries may have restrictions regarding the use of Bluetooth® devices. Information can be obtained from the local authorities.
- If the 12 V vehicle battery has been disconnected, switch on the ignition before switching on the Infotainment system.
- Displays on the screen may vary due to differences in the settings, and the Infotainment system may function differently than described in this manual.
- The Infotainment system will switch off automatically when the engine stops and if the 12 V vehicle battery charge level is low.
- In some vehicles with a parking system, the volume of the current audio source may be automatically lowered when you shift into reverse. The volume reduction level can be adjusted.
- The Infotainment system contains information about the software contained in the system and the licensing terms under: Setup ► Copyright.
- If selling or loaning your vehicle, make sure that all saved data, files and settings are deleted, and that the external SD card, external audio sources and data carriers are removed, if necessary.
- Certain functions in the Infotainment system require an active VW Car-Net account for the vehicle and an online connection to the Internet. In order to enable functions to be carried out, data transfer must not be restricted.

Overview and controls of the 8" version

 Refer to  and  *Safety instructions*.



Fig. 135 Overview: display and control unit, 8" version.

① Possible sensor areas for opening main menus:

- **(RADIO)** ⇒ Radio mode.
- **(MEDIA)** ⇒ Media mode.
- **(PHONE)** ⇒ Mobile phone interface.
- **(VOICE)** ⇒ Voice control. The button does not have a function in some countries.
- **(NAV)** ⇒ Navigation.
- **(APP)** ⇒ App-Connect. The button does not have a function in some countries.
- **(SOUND)**.
- **(CAR)**.
- **(MENU)** Opens the home screen.

② Rotary knob.

③ Function keys for main menus.

④ Views (current view is highlighted).

⑤ Control Center.

⑥ Menu knob.

 Further information and tips for operating the Infotainment system are available at ⇒ [Operating the Infotainment system](#).

① Touch-sensitive fields

1. To open a main menu, tap the corresponding sensor area, e.g. **(PHONE)** for the phone interface.

② Rotary knob

- Press to switch the Infotainment system on or off.
- Turn left to decrease the volume.
- Turn right to increase the volume.

③ Function keys for main menus

It is not possible to configure the position of the function keys.

1. To open a main menu, tap the corresponding function key e.g.  for the phone interface.

④ Views (current view is highlighted)

Certain menus and functions have multiple views with different content. The current view is highlighted.

- Tap a selection to switch to a view.
- Swipe left or right on the screen to switch between views.

⑤ Control Center

The Control Center contains additional function keys for functions and notifications. Displayed functions can be configured ⇒ [Personalizing the Infotainment system](#)

1. Tap the selection and swipe down to open the Control Center.

⑥ Menu knob

1. Turn to control the list selection.
2. Press to confirm a selection.

Screen (touchscreen) (without position numbers)

You can operate the Infotainment system functions via the screen. You will find detailed explanations of the different finger movements in the digital manual for the Infotainment system, if available.

1. Tap   ▶ Operation.

Scroll bars (without position numbers)

Certain menus and functions contain additional content above and below the content currently displayed on the screen.

1. Tap the scroll bar and swipe down or up to display additional content.

Gesture control (without position numbers)

Gesture control can also be switched on. If gesture control is switched on, this is shown on the screen.

1. Tap   ▶ Screen ▶ Hand gesture.

Operating the Infotainment system

 Refer to ⇒  and  [Safety instructions](#).

Opening the digital manual of the Infotainment system (if available)

Further information and tips on operation can be found in the digital manual for the Infotainment system.

1. Tap   ▶ .

Switching the Infotainment system on and off

The Infotainment system starts up when the ignition is switched on, unless it was previously switched off manually.

The Infotainment system starts at the volume that was last set, as long as this does not exceed the preset maximum switch-on volume.

Vehicles with starter button: If the driver door is opened while the ignition is not active, the Infotainment system switches off automatically.















 If you switch on the Infotainment system manually while the ignition is not active, it will switch off automatically after approximately 30 minutes without user input.

Opening the home screen

1. Tap  ⇒ [Overview and controls of the 8" version](#).

Main menus on the home screen

The following main menus may be shown as function keys on the home screen:

 Ambient lighting, ambient light ⇒ [Interior/reading lights, ambient lighting](#).  App-Connect ⇒ [App-Connect](#).  Apps.  Driver assistance ⇒ [Driver assistance systems](#).  Vehicle ⇒ [Driver information](#).  Help: Here, you can find additional information about Infotainment system functions and operation, e.g. the quick guide.  Climate control ⇒ [Heating and air conditioning system](#).  or  Sound ⇒ [System and sound settings](#).  Media ⇒ [Media mode](#).  Navigation ⇒ [Navigation](#).  Radio ⇒ [Radio mode](#).  Legal.  Setup ⇒ [System and sound settings](#).  Telephone ⇒ [Mobile phone interface](#).

Configuring the home screen

In the display and control unit, you can configure the arrangement of the function keys, views and displays on the home screen or have them positioned by means of factory-supplied layout templates. The home screen cannot be configured in all available Infotainment systems.

1. Tap the function key and hold until the function key is highlighted.
2. Move the function key to the preferred position and release it.

Scrolling through lists, switching titles

Select your desired function, setting or track via the touchscreen or the control knob.

Moving objects, adjusting volume

To adjust settings, e.g. those using sliders, or move areas of a menu around, move the objects around on the screen.

Personalize function keys and views depending on the vehicle equipment ⇒ [Personalizing the Infotainment system](#).

Zooming in or out of pictures and maps shown on the screen

Recommendation: Use thumb and index finger.

1. Tap and hold the screen with two fingers at the same time.
 - To zoom in on the pictures and maps shown, slowly move your fingers apart.
 - To zoom out of the pictures and maps shown, slowly move your fingers together.

Personalizing the Infotainment system

Refer to ⇒  and  [Safety instructions](#).

Depending on the vehicle equipment, you can personalize the Infotainment system to access your favorite and frequently used functions quicker.

The Infotainment system views contain tiles for accessing additional menus and functions.

Adjusting tiles

Adjust the tiles and displayed tile functions in the Infotainment system views to manage the Infotainment system as you wish.

1. Tap and hold tiles until an additional window appears.
2. Tap the desired function in the additional window ⇒ [Operating the Infotainment system](#). Various functions are available depending on the size of the tile.

Or: to return to View, tap any free area of the screen.

 There are always at least two views available. They cannot be removed. Depending on the vehicle equipment, you can add two further views. A maximum of four views can be displayed.

 For some tiles, more functions are available than can be seen initially in the additional window. To see all the functions, swipe up or down in the additional window.

Adjusting the Control Center

Personalize the Infotainment system Control Center to access your favorite and frequently used functions quicker.

1. Tap and hold the function until an additional window appears.
2. Tap the desired function in the additional window and hold until the function is highlighted.
3. Move the function to the preferred position and release it.

The active function is automatically removed from the Control Center and added to the additional window.

 For the Control Center, more functions are available than can be seen initially in the additional window. Swipe to the left or right in the additional window to see all the functions.

Opening personalization tips (if available)

Further information and tips on personalization can be found in the digital manual for the Infotainment system.

1. Tap    Adjustment.





System and sound settings

Refer to ⇒  and  [Safety instructions](#).

Changing settings

The meanings of the following symbols apply to all system and sound settings.

Changes will be automatically applied when the menu is closed.

or The setting is selected and activated or switched on. or The setting is not selected and deactivated or switched off.  or  Open the drop-down list.  Increase the set value.  Reduce the set value.  Go back stepwise.  Go forward stepwise.  Use the slide control to continuously change the set value.

System settings

The system settings may include the following functions, information, and setting options:

- Screen.
- Time and date.
- Language.
- Additional keyboard languages.

- Units.
- Voice control.
- Wi-Fi.
- Data connection.
- Manage mobile devices.
- Restore factory settings.
- System information.
- Copyright.
- Configuration assistant.

Opening system settings

1. Tap **(HOME)** ► Setup.
Or: Tap **(MENU)** ► Setup.

Sound settings

The sound settings may include information and setting options for equalizer, position, volume and setup.

Opening sound settings

1. Tap **(HOME)** ► Sound.
Or: tap **(MENU)** ► Sound.

Adjusting the volume of external audio sources

Lower the volume of the Infotainment system before turning up the volume of an external audio source.

If the connected audio source plays too quietly, increase the output volume of the external audio source. If that does not correct the problem, set the input volume to Medium or Maximum.

If the connected external audio source plays too loudly or the sound is distorted, lower the output volume of the external audio source. If that does not correct the problem, set the input volume to Medium or Minimum.

Cleaning the screen

 Refer to  and  *Safety instructions*.

When cleaning the screen, please note this checklist:

- ✓ The Infotainment system is switched off.
- ✓ Use a soft, clean cloth that has been moistened with water.
Or: use a cleaning cloth which is available from an authorized Volkswagen dealer or authorized Volkswagen Service Facility.
- ✓ For stubborn dirt:

NOTICE

If you clean the screen with incorrect cleaning agents or when dry, you may damage it.

- Only apply gentle pressure.
- Do not use any aggressive cleaners or products which contain solvents. These types of cleaners can damage the device and cause glare on the screen.

NOTICE

If the cloth used to clean the screen is too moist, the screen can no longer be operated or switched off.

- Dry the screen and then leave the vehicle locked from the outside for at least two minutes.

Brands, licenses, copyright

 Refer to  and  *Safety instructions*.

Brands and licenses

Certain terms in this manual have the ® or ™ symbols. These symbols indicate emblems or registered trademarks. However, the absence of this symbol does not constitute a waiver of any rights associated with intellectual property.

Other product names are registered trademarks for the respective rights holder.

- Manufactured under license from Dolby Laboratories. Dolby and the double-D symbol are trademarks of Dolby Laboratories.

- Manufactured under license from Dolby Laboratories. Dolby, Pro Logic and the double-D symbol are trademarks of Dolby Laboratories.
- All SiriusXM services require a subscription. See the SiriusXM Customer Agreement for complete terms at www.siriusxm.com (US) or www.siriusxm.ca (Canada). All fees, content and features are subject to change. Satellite and steaming lineups may vary. SiriusXM, Pandora and all related logos are trademarks of Sirius XM Radio Inc. and its respective subsidiaries. All rights reserved.
- HD Radio Technology manufactured under license from iBiquity Digital Corporation. U.S. and Foreign Patents. For patents see <http://dts.com/patents>. HD Radio, Artist Experience, and the HD, HD Radio, and "ARC" logos are registered trademarks or trademarks of iBiquity Digital Corporation in the United States and/or other countries.
- Android Auto™ is a certified trademark of Google, Inc.
- Apple CarPlay™ is a certified trademark of Apple, Inc.
- Bluetooth® is a registered trademark of Bluetooth® SIG, Inc.
- iPod®, iPad®, and iPhone® are registered trademarks of Apple Inc.
- MirrorLink® and the MirrorLink® logo are certified trademarks of the Car Connectivity Consortium LLC.
- MPEG-4 HE-AAC audio coding technology and patents licensed from Fraunhofer IIS.
- SD® and SDHC® are brands or registered trademarks of SD-3C, LLC in the USA and other countries.
- Windows® is a registered trademark of Microsoft Corporation, Redmond, USA.
- This product is protected by the intellectual property rights of Microsoft Corporation. Use or distribution of such technology outside of this product is prohibited without a license from Microsoft or an authorized Microsoft subsidiary.

SPOTIFY and the Spotify logo are among the registered trademarks of Spotify AB. Compatible vehicle and Spotify Premium subscription required, where available.

Copyright

Audio and video files saved on data carriers and audio sources are generally subject to copyright regulations in compliance with applicable international and nation laws. Observe legal regulations.





Radio mode

Introduction



In radio mode you can receive various available radio stations on different frequencies and save your favorites to the station buttons for quick access.

Available reception modes and bands depend on the vehicle equipment and are not available in all countries. Frequency bands in individual countries may be discontinued, switched off or no longer offered.

Opening the Radio mode main menu

1. Tap **(HOME)**   .
- Or: tap **(MENU)** .
- Or: tap **(RADIO)**.
- Or: press **(RADIO)**.

Opening the settings

1. Tap **(HOME)**     Radio.
- Or: Tap **(MENU)**   .
- Or: Tap **(RADIO)** .
- Or: Press **(RADIO)** and tap .

 **The radio stations are responsible for transmitted content.**

 **Other electrical devices connected in the vehicle can impair radio signal reception and cause noise in the speakers.**

 **Decals or metal-coated stickers on the vehicle windows can impair radio reception in vehicles with window antennas.**

Functions and radio symbols

 Refer to   and  **Safety instructions.**

Radio

The available scope of functions and also possible reception modes and bands depend on the vehicle equipment and are not available in all countries.

- AM tuner.
- FM dual tuner (diversity aerial).
- Station list of FM stations.

- Summarized memory list.
 - Merging of all stations stored on station preset buttons in a list.
 - Up to 36 station preset buttons as storage locations for favorites.
- Station logos.
- Antenna amplifier
- Internet radio.
- HD Radio™.
- Satellite radio:
 - SiriusXM™.
 - SiriusXM™ online.

General symbols for radio operation

The symbols may look different depending on the Infotainment system.

Select a AM reception mode. Select a FM reception mode. Select the Internet Radio reception mode. Select the satellite radio reception mode. Display additional information about the station. Select the previous station from the station list or station on the previous station preset button. Select the next station from the station list or station on the next station preset button. Display the preset list with station preset buttons. Stations already stored on a station preset button in a station list. or Open settings.

Symbols in the AM frequency band

Show the station list of AM stations. Manually update the station list. Display the frequency band for manual selection of the AM frequency.

Symbols in the FM and FM/DAB frequency band

Show the station list of FM and country-dependent DAB stations. Display the frequency band for manual selection of the FM frequency.

Only possible when the summarized station list is switched off.

Symbols for Internet Radio operation

Open full-text search. Unable to receive Internet radio. Display the last internet radio station. Display the 100 most popular internet radio stations. Display the available Internet Radio podcasts. Display Internet Radio stations that originate from the preferred country. Display Internet Radio stations that transmit their program in the preferred language. Display Internet Radio stations whose programs are of the preferred genre. Display the station selection.

Symbols for HD Radio operation

Station supports HD Radio. Radio or Tune the HD Radio substations. Open the Emergency list of the “HD Radio Emergency Alerts” function. Radio - HD Radio logo.

Symbols for satellite radio operation

Display the channel list. Open the window for entering the channel number.

Adjusting, tuning, and storing stations

Refer to and *Safety instructions*.

Selecting the frequency band or reception mode

Before selecting a station, you must first select a frequency band or reception mode. Various stations are available, depending on the selected frequency band or reception mode.

1. Tap Source to open the list of frequency bands and reception modes.
2. Select the band or reception mode, e.g. FM.

Searching for and selecting a station

There are different ways to search for and select stations. The options vary based on the frequency band and reception mode.

Selecting via the frequency band (AM and FM)

You can select frequencies and save them as favorites.

1. Tap .
2. Tap the cursor to press and slide to the frequency band and release at the desired frequency.

Or: tap a point on the frequency band. The cursor automatically jumps to the corresponding frequency.

The station at the set frequency will be tuned.

Selecting from a station list (AM, FM and FM/DAB)

The station list displays the stations that currently can be received. Depending on the vehicle equipment, it is possible that the station list must be manually updated if you have left the area since the last time the station list was opened. The station list in the FM/DAB band generally updates automatically.

1. Open the station list.
2. Tap the desired station.

The selected station will be tuned.

Searching for and filtering stations (Internet Radio)

In Internet Radio mode, stations can be filtered according to category or searched for using a full-text search.

1. Open the station selection.
2. Select the categories by which to filter the stations.

Or: to start the full-text search, tap .

The input line is displayed.

3. Enter the name of the desired station.

The list of the found stations updates automatically during input.

4. Tap the desired station.

The selected station will be tuned.

SCAN Search in SCAN mode (AM, FM and FM/DAB)

In SCAN mode, the stations in the frequency band are set automatically in succession and played for approx. 5 seconds each.

1. To start SCAN mode, tap  SCAN.

SCAN mode starts and the current station is shown on the display.

The SCAN function key is shown.

2. To select a station, tap SCAN.

SCAN mode stops and the station is tuned.

Storing stations on the station preset buttons

You can save up to 36 stations from different frequency bands and reception modes as favorites on the station preset buttons.

1. Tune the desired station.

2. Tap .

Or: tap and hold the station on the station list.

The station preset buttons are displayed.

3. Tap and hold the station preset button until the station is saved.

The station is saved on the selected station preset button.

If a station was already saved on the station preset button, this station will be removed from the station preset button and replaced by the new station.

Special functions in radio mode

 Refer to  and  **Safety instructions.**

The special functions in radio mode listed below are not available for all Infotainment systems, depending on the vehicle equipment, and may not be available in all countries.

Internet radio

Internet radio is a reception mode for Internet radio stations and podcasts independent of AM, FM and DAB. Due to its transmission over the internet, receipt is not regionally limited.

Internet radio is only available if the Infotainment system has an active Internet connection. Costs for streaming data online may result when using Internet radio.

 **This function of the Internet Radio in some countries depends on your vehicle privacy settings.**

Station logos

Station logos can be preinstalled for some frequency bands in the Infotainment system.

If the Automatic station logo selection function is activated in the settings, the station logos are automatically assigned to the stations.

In Internet radio mode, the Infotainment system obtains the station logos from an online database and assigns them automatically to the stations.

Assigning station logos manually

Station logos cannot be assigned manually in the AM frequency band.

1. Tap  Station logos in radio mode.

2. Select the station to which a station logo should be assigned.
3. Select the station logo.
4. This process can be repeated for additional stations.
5. To finish assigning station logos, tap .

Online functions in radio mode

 Refer to   and  *Safety instructions*.

Depending on the vehicle equipment, the Infotainment system features online functions in radio mode.

Online functions in radio mode are not available in all countries and vehicle models.

Online functions in radio mode include Internet Radio, for instance.

Prerequisites for using online functions in radio mode:

- ✓ The vehicle is equipped with VW Car-Net.
- ✓ You have registered and you have an active VW Car-Net user account.
- ✓ The vehicle is assigned to your VW Car-Net user account.
- ✓ You have purchased a corresponding active data package for an Internet connection and have also purchased a “Plus Online Radio subscription” via the VW Car-Net app or the VW Car-Net website, USA: vw.com/carnet, Canada: vw.ca.

SiriusXM

 Refer to   and  *Safety instructions*.

SiriusXM is a satellite radio station that can be received in the USA and Canada. Satellite radio services are subject to fees and must be enabled for the Infotainment system by phone or online.

SiriusXM subscriptions can be activated via cell phone.

The current status of the subscription can be shown in the settings in satellite radio mode.

Further information can be found in the settings in satellite radio mode under Help and support and on the Internet:

In the USA:

www.siriusxm.com

In Canada:

www.siriusxm.ca

Displaying the SiriusXM ID

Each radio has its own SiriusXM ID with which you can manage your subscription.

1. In satellite radio mode: Tap  ► Subscription Information.

Or: In satellite radio mode: Tap  and enter channel number “0”.

The SiriusXM ID, the website and phone number for the SiriusXM activation hotline will be displayed on the screen.

SiriusXM with 360L

Your vehicle can be equipped with SiriusXM with 360L. SiriusXM with 360L offers both satellite and streaming connectivity for a multitude of music, news, sports, ta and entertainment channels and content. With SiriusXM with 360L, you have a personalized listening experience with recommendations and functions based on your listening habits.

SiriusXM live channels

The channels available depend on the enabled services. All available channels are displayed in the channel list.

Each channel is assigned a channel number.

The channels are sorted in the channel list according to their channel number. The channels can be opened directly via their channel number under .

All channels are sorted according to categories. Within the categories, the channels are sorted according to genre. Channels can be browsed in categories, e.g. music.

Setting SiriusXM live channels

Available channels can be set in various ways depending on the vehicle equipment.

1. In satellite radio mode: Tap  and set the preferred channel using the channel number.

Or: Tap the title image of the preferred channel.

Or: turn the knob, select the preferred channel and press it.

2. *Optional:* To search for channels with content related to the content currently being played, tap Related in the station display.

A list with related content will be displayed.

On Demand

SiriusXM with 360L offers access to a multitude of on-demand content, e.g. concerts.

Opening on-demand content

1. Select a channel category, e.g. music, and select a genre, e.g. rock.
2. Tap On Demand.
3. *Optional:* To search for on-demand content related to the content currently being played, e.g. shows, tap Related in the station display.

A list with related content that is currently playing will be displayed.

Live Sports

With the category of “Live Sports”, you can call up transmissions of games that are being aired on SiriusXM.

Opening Live Sports

1. Select the category “Live Sports”.
2. Select the preferred transmission of a game.

Play Ahead Controls

With the “Play Ahead Controls” function, both live and on-demand content can be played and paused, and you can jump forwards or backwards in the playback.

Presets

SiriusXM live channels and on-demand shows can be saved as a preset. Up to 36 presets can be saved.

Saving SiriusXM content as Presets

1. To save a live channel currently being played back or an on-demand show currently being played back as a preset, press and hold a preset bank.

Or: In the channel list or the list of on-demand shows, press and hold the preferred content and select a preset bank.

Listening profile

The personalized listening profile saves recommendations based on the program content currently being listened to and the latest listening history, and is regularly updated.

The listening profile can be set up in the Volkswagen user account and used with the SiriusXM app.

Setting up a listening profile

1. In satellite radio mode: To create a new listening profile, tap .

Or: In satellite radio mode: Tap   Create new listening profile.

Personalized SiriusXM recommendations

A collection of personalized SiriusXM recommendations is available for each listening profile.

The personalized SiriusXM recommendations are regularly updated, based on what you're listening to.

Displaying personalized SiriusXM recommendations

1. Tap For You.

Listening history

For each listening profile, a list of SiriusXM content recently listened to is displayed. This listening history can be displayed and reset at any time.

HD Radio

 Refer to   and  *Safety instructions*.

HD Radio is a digital radio station that can be received in the USA and Canada.

HD Radio Technology

Some AM and FM radio stations also transmit their content digitally via HD Radio Technology.

When the function is activated in settings in the AM or FM band and the current station supports HD Radio Technology, the  function key appears on the Infotainment system display. The Infotainment system switches automatically between digital and analog reception depending on the reception quality. If the station is currently received in analog mode, the function key is grayed out.

Some stations offer additional substations via HD Radio Technology (multicast programming). If this is the case, HD1 is displayed after the station frequency of the main station. Substations are marked with HD2, HD3, etc.

Tuning the HD Radio substations

1. Tap  to cycle through the available substations.

Or: Select an additional station from the station list.

Or: to cycle through the additional stations individually, tap < or >.

The substation that is currently selected is displayed after the main station on the screen (for example ... HD3 for the second substation).

 The available substations of the current stations are displayed on the station list.

Additional HD Radio Technology services

1. To select your chosen additional service, tap View.

HD Radio Emergency Alerts

The “HD Radio Emergency Alerts” function can be used to receive reports of unusual, potentially life-threatening events, such as natural disasters. These notifications are played as pop-up notifications while the radio is on. This function is activated in the factory.

If you tap Remind me later when a notification appears, the notification will appear again about ten minutes later. If you tap Close, the notification will be moved to the Alert list. If the “HD Radio Emergency Alerts” function is deactivated, these notifications are moved directly to the Alert list and indicated by  and a number in the status bar. The number on the symbol displays the number of notifications.

Activating or deactivating HD Radio Emergency Alerts

1. In radio mode, activate or deactivate  ► Radio ► Emergency notifications.

Opening the Alert list

Up to five notifications can be displayed in the Alert list.

1. Tap  in radio mode.

Media mode

Introduction

In media mode, you can play back media files from data carriers in the Infotainment system.

Depending on the vehicle equipment, the following data carriers can be used:

- USB storage medium, e.g. USB flash drive.
- Bluetooth device, e.g. cell phone.







Depending on the vehicle equipment, the following types of media files can be played:

- Audio files, e.g. music.
- Video files.











Streaming services

You can also use streaming services, depending on the vehicle equipment and in some countries ⇒ [Online functions in media mode](#).

Opening the MEDIA main menu

1. Tap  ► .
- Or: tap  ► .
- Or: Tap .
- Or: Press .

Opening the settings

1. Tap  ►  ► .
- Or: Tap  ►  ► .
- Or: Tap  ► .
- Or: Press  and tap .

Restrictions and instructions for data carriers

Dirty, overheated or damaged data carriers are not to be used. Read and heed the information provided by the manufacturer.

Difference in quality between data carriers from different manufacturers can cause problems with media playback.

Wrong configuration of data carriers can lead to the data carriers being unreadable.

The storage volume, condition (copy and delete processes), file system, folder structure and the amount of saved data can increase the time taken to read data carriers.

Playlists only define the order of play and refer to the saved location of the media files within the folder structure. No media files are saved in playlists. To play a playlist, the media files must be present in the data storage device memory location, to which the playlist refers.

 Volkswagen is not responsible for damaged, altered or lost files on data carriers.

Functions and media symbols

 Refer to ⇒  and  Safety instructions.



Audio, media, connectivity

The available scope of functions and possible media formats depend on the vehicle equipment and are not available in all countries.

The symbols may look different depending on the Infotainment system.













- Media playback and media control via Bluetooth.
- Audio playback in these formats:
 - AAC.
 - APE.
 - ALAC.
 - FLAC.
 - MP2.
 - MP3.
 - MP4.
 - Vorbis.
 - OPUS.
 - WMA.
 - WAV.
- Video playback in these formats:
 - MPEG-1 and MPEG-2 (.mpg, .mpeg, .mkv, .avi).
 - ISO MPEG-4 ASP; Xvid (.mp4, .m4v, .mov, .mkv, .avi).
 - ISO MPEG-4 AVC/H.264 (.mp4, .m4v, .mov, .mkv, .avi).
 - Windows Media Video 9 (.wmv, .asf, .mkv, .avi).
- Cross-device playlists.
- Cross-source media database:
 - Data from all media sources connected to the Infotainment system are stored in a media database.
- Media streaming (online).
- Media search.

Symbols for media sources

 Select My media as a media source. Connected USB devices may be selected under My media.  Select a device connected via Bluetooth as a media source.  Set up available streaming services.

Streaming services which have already been set up are represented by their own logos in the list of media sources.

General symbols for media operation

 Start replay.  Pause replay.  Go to the previous track.  Skip to the next track.  Repeats the current track.  Repeats all tracks.  Activate random playback.  Search current media source (list view).  Close list view.  Open settings.  Go back one folder level in the media source.  Display favorites list.

Symbols for categories and groups of media files

 Music tracks.  Videos.  Playlists.  Albums.  Artists.  Genres.  Podcasts.  Audiobooks.

Video replay symbols

 Replay video in full-screen mode.  Minimize replay.

Selecting and playing a media source

 Refer to  and  and  Safety instructions.

Selecting a media source

1. If you want playback from an external media source, connect the external media source.
2. Select the connected media source to be used for playback.

▶ Playing audio and video files

A media source must be connected and selected before media files can be played back.

There are different ways to search for and play media files from an available media source.

≡ Searching the folder structure

All media files from USB devices are filtered by category (e.g. albums). This category view is always displayed In My Media. The classic folder structure of the

individual USB data carriers can also be found in the My Media menu.

1. Display the folder structure.

The folder structure of the selected media source is displayed. If My Media is selected, the categories (e.g. music) and connected media sources are displayed

2. Searching the folder structure for a desired track.

Or: to start the full-text search, tap .

The input line is displayed.

3. Enter the name of the desired track.

The list of the found tracks updates automatically during input.

4. Tap the desired track.

When playback starts, if the selection is located in a folder on a media source, all of the media files located in the folder will be added for playback.

If a playlist is played back, all available tracks on the playlist will be added for playback.

5. Close the selection with .

☆ **Selecting from favorites**

You can save individual tracks, albums, artists and genres under favorites for playback.

1. Open Favorites.
2. Tap on your favorites.

Depending on the selection, all tracks heard during the current playback will be added to favorites.

☆ **Saving favorites**

Only media files that are saved in My Media in the music and video folders can be saved as favorites. You can save individual tracks, albums, artists and genres as favorites.

1. Start playback of the desired track.
2. Open Favorites.
3. Tap the free favorite position.

Or: tap on an already occupied favorite position, and press and hold for approx. three seconds.

4. Select from the selection list:



- Title.
- Albums.
- Artists.
- Genres.
- Playlists.

The selection is saved in the selected favorite position as a favorite. If the favorite position was already occupied, the previously saved favorite is overwritten.

The selection options in the selection list depend on the data attached to the media file. If a genre is not indicated for music files, the genre cannot be saved as a favorite.

If a video file is currently being replayed, only this video can be saved as a favorite.

Setting up streaming services

Depending on the vehicle equipment and in some countries, you can use streaming services directly through the Infotainment system ⇒  [Introduction](#). There must be an internet connection to use streaming services ⇒  [Introduction](#).

1. Select Media Streaming as the media source.

A list of available streaming services is displayed.

2. Select the desired streaming service.

Either an input field for inputting the registration data is shown or a guide to registering with the provider is displayed.

3. Enter the login data for the desired user profile and confirm.

The streaming services will be added as a new function key in the list of media sources.

 **Depending on the country, you may need to log in to the streaming service again if you change your privacy settings, for example.**

Entertainment playback via the Infotainment system

 **Refer to** ⇒  **and**  **Safety instructions.**

The Infotainment system can play music and videos.

Video mode

In video mode, the Infotainment system display can play a video from a data carrier ⇒ [Selecting and playing a media source](#).

Depending on the vehicle equipment and in some countries, video from a streaming service can also be played back ⇒ [Selecting and playing a media source](#).

The video sound is played back via the vehicle speakers.

A stable Internet connection is required for playback via a streaming service. There may be costs associated with your mobile network provider for doing so.

The video image is only displayed when the vehicle is stationary. The Infotainment system display will be switched off when the vehicle is moving. The video sound will continue to be played.

In some countries, for road safety reasons, no video image is shown even when the vehicle is stationary.

Online functions in media mode

Refer to ⇒  and  [Safety instructions](#).

Depending on the vehicle equipment, the Infotainment system features online functions in media mode.

Online functions in media mode are not available in all countries and vehicle models.

Online functions in media mode include streaming services, for instance.

Prerequisites for using online functions in media mode:

- ✓ The vehicle has VW Car-Net.
- ✓ You have registered and you have an active VW Car-Net user account.
- ✓ Your vehicle is assigned to your user account.
- ✓ You have purchased a corresponding active data package for an Internet connection via the VW Car-Net app or via the VW Car-Net website, USA: vw.com/carnet, Canada: vw.ca.

Streaming services

Depending on the vehicle equipment, you can also use streaming services.

Streaming services are not available in all countries and vehicle models.

Prerequisites for using streaming services:

- ✓ The prerequisites for using online functions in media mode must be fulfilled.
- ✓ You have your own user account for the relevant streaming service.

Navigation

Introduction

The current vehicle position is determined by a global satellite system. In order to enable optimum navigation to your destination, all measured values and possible traffic information are compared with the available map material.

Audible navigation aids and graphic representations lead you to your destination. Audible navigation aids Acoustic navigation announcements and graphic displays lead you to your destination.

In some countries, it may not be possible to select some Infotainment system functions on the screen when driving above a certain speed. This is not a malfunction but rather compliance with legal regulations.

WARNING

Only adjust settings, enter destinations, or change navigation information when the vehicle is stationary.

 If you missed a turn on your route, the navigation system may recalculate the route.

 The quality of the driving directions depends on the available navigation data and any reported traffic incidents.

 Traffic information is only given in the navigation system if the available VW Car-Net service has been activated.

Opening the navigation system main menu

1. Tap  ▶ .
- Or: tap  ▶ .

Opening the settings

1. Tap  ▶  ▶ .
- Or: Tap  ▶  ▶ .

Navigation restrictions

If the Infotainment system cannot receive data from GPS satellites, for example in a tunnel, navigation will still be possible using the vehicle's sensors.

In areas that are not digitized or only partially digitized in the Infotainment system memory, the Infotainment system will still try to provide route guidance. If navigation data is missing or incomplete, the vehicle position may not be determined accurately. This may result in navigation that is not as accurate as usual. Routing is subject to ongoing changes, like new streets, construction zones, road closures, or changes to street names or house numbers. Using outdated navigation data can lead to errors or uncertainty when using route guidance.

Function descriptions

 Please read the introductory information and heed the Warnings and Notice ⇒  and  Safety instructions.

Voice guidance

Navigation messages are acoustic driving directions for the current route.

The type and frequency of navigation messages depends on the settings and the driving situation, like the start of the route guidance and whether you are driving on a highway or roundabout.

If the destination cannot be reached exactly, for example because it is not in a digitized area, there will be a navigation announcement that the Destination area has been reached. Messages about the direction and distance to your destination will also be displayed on the screen.

During dynamic route guidance, reported traffic incidents on the route are announced. There will be an additional navigation announcement if the route is recalculated due to a traffic incident or a change in driving style.

You can adjust or mute the volume during a traffic announcement. All other navigation announcements will be given at that volume or will be muted.

 Navigation messages will not be given if the Infotainment system is muted.

Adapting the Navigation Map

To ensure an optimum view, you can also adapt the navigation map and map view using enhanced finger movements.

Moving the navigation map

Recommendation: Use index finger.

1. Move the navigation map with your finger.

Zooming in or out on the map view

Recommendation: Use index finger.

1. Tap and hold the map twice in a row.
2. To zoom out of the map view, move your finger upwards. To zoom in on the map view, move your finger downwards.

Zooming in or out on the map view

Recommendation: Use thumb and index finger.

1. Tap and hold the map with two fingers at the same time.
2. To zoom out of the map view, slide your fingers towards each other. To zoom in on the map view, slide your fingers away from each other.

Tilting the map view

Recommendation: Use index and middle finger.

1. Tap and hold the map with two fingers at the same time, held horizontally next to each other.
2. To tilt the map view to the front, move your fingers upwards. To tilt the map view to the back, move your fingers downwards.

Rotating the map view

Recommendation: Use thumb and index finger.

1. Tap and hold the map with two fingers at the same time.
2. Turn your fingers clockwise or anti-clockwise to turn the map view.

Route plan

The route plan contains information about relevant events, such as waypoints and destination suggestions, if the relevant data is available to the navigation system. Tapping an event will open a dialog box with additional options. The options available depend on the event and the current settings ⇒  Introduction.

Opening and closing the route plan

1. Tap the route plan to open.
2. To stop route guidance, tap >.

Editing route guidance

To edit route guidance, move the stopovers or the destination in the route plan.

1. Tap and hold the desired destination until it is visibly highlighted.
2. Move the destination to the desired position and release it.

The route will be recalculated.

Additional dialog box in the route plan

Tapping the route plan entries may cause a dialog box to open with additional options for these entries. The options available depend on the entry that is tapped.

Functions in the split screen:

Display on map Displays the selection on the map.

Add waypoint Adds a waypoint to the route guidance.

Direct route Starts direct route guidance.

Delete Delete waypoint from route guidance.

Avoid Avoid traffic disruptions. The route will be recalculated.

Stop route guidance Ends the current route guidance.

Closing an additional dialog box in the route plan

1. Tap a free area outside of the additional window.

Setting preferred POI categories

The system offers different points of interest, e.g. gas stations, using the quick select symbol when entering destinations, in the route plan and on the map. You can prioritize how these symbols are displayed under  Basic function settings ► Preferred POI categories. The system also automatically learns your preferred categories.

Saved data

In order to enable you to enter destinations quickly and to optimize route guidance, the Infotainment system saves certain data, such as frequently driven routes and positioning data.

Delete saved data

1. Tap  Basic functions ► Delete usage pattern.
2. Tap confirm to delete the data.

Learning usage patterns

While driving, the Navigation system saves routes traveled and destinations reached in order to create automatic destination suggestions. Destinations are learned with reference to the time of day and the day of the week.

The navigation system can suggest pre-learned routes.

1. Tap  to show the suggested routes.

Selecting one of the suggested routes will cause route guidance to begin.

The route guidance follows the selected route until you deviate from it. The route will then be recalculated and will lead back to the selected route via the most direct path.

Serious traffic disruptions are taken into consideration in route guidance. If an alternative route and the navigation data are available, serious disruptions will be avoided.

If you are driving a pre-learned route without active route guidance, the destination is added to the route plan. Route guidance does not need to be actively started for a journey to a pre-learned destination. You are warned about traffic disruptions if necessary.

A predicted arrival time is displayed.

You can activate or deactivate this function at any time as well as delete the saved data for this function.

Activating or deactivating “Learn usage pattern”

1. To open this function's settings, tap  Basic function settings.
2. Tap Learn usage pattern.

Deleting saved “Learn usage pattern” data

1. To open this function's settings, tap  Basic function settings.
2. To delete saved data, tap Delete usage pattern.

Functions and symbols of the navigation system

 Please read the introductory information and heed the Warnings and Notice  and  Safety instructions.

Navigation

The functions and symbols of the navigation system may differ depending on the vehicle equipment and are not available in all countries.

Functions

- Entering a destination and route calculation.
- Simultaneous display of two navigation maps (screen and instrument cluster).
- Personal destinations.
- 3D City Maps.
- Online Map Update.

Symbols on the map

The function keys and displays shown depend on the settings and the current driving situation.

Symbols for traffic information, e.g. traffic disruptions, and POIs, e.g. gas stations, are displayed on the map if the data is available to the navigation system.

Display current position. Destination search. Destinations and stopovers along the current route. Personal destination suggestions (home address, work address, favorite POIs nearby). Display route options. Fully automatic map mode (orientation in direction of travel, position, zoom and tilt). Determine driving direction and map tilt. Map scale. Display destination memory. Display dialog box with additional options. Map menu with settings for navigation and navigation announcements.

Symbols in the dialog box

- To open the additional window, tap on .

Display route overview and alternative routes to the current route guidance. Repeats the last navigation announcement. Mute or adjust volume of navigation instructions. Navigation settings.

Additional symbols

Destination search: detailed destination input for an address.

Symbols in the route plan

Display current position. Destination for the current route guidance. Ends the current route guidance. Close route plan.

Traffic disruptions

Traffic disruptions are displayed on the map if the data is available to the navigation system.

Tap a traffic disruption to open a dialog box with details ⇒ [Function descriptions](#).

Traffic jam. Accident. Ice. Road closed. Slip hazard. Danger. Construction zone. Strong wind.

Inputting destinations and starting route guidance

Please read the introductory information and heed the Warnings and Notice ⇒ and Safety instructions.

Depending on the vehicle equipment, different functions are available for inputting destinations. Some functions are only available in some countries.

The various functions for inputting destinations are located in the navigation system main menu ⇒ Introduction.

You can further restrict your search with specific suggestions in the results list, e.g. “nearby”.

For further information about symbols on the Infotainment system screen, see ⇒ [Functions and symbols of the navigation system](#).

Enter address

Start route guidance by entering an address. During input, the navigation system suggests already known destinations. You can also enter a new, unknown address for route guidance.

When inputting the address, input the name of the destination, not the postcode of the destination.

Selecting the destination and starting the navigation system

1. Tap .
2. Enter the destination address and select your desired destination.

Or: tap and enter the address via the input screen.

3. Tap Route.

Quick start

1. Tap .
2. Enter the address of the destination, tap the desired destination and hold for a few seconds.

Enter the destination as accurately as possible. If there is an error in the destination entered, route guidance cannot take place or may lead to the wrong destination.

Destination suggestions

Navigation uses saved data such as your last destinations, learned destinations, favorites, home address and work address to provide you with route guidance.

Selecting the destination and starting the navigation system



1. Tap .
2. Tap on the desired destination.

The route guidance starts automatically.



Last destinations

The navigation system saves up to ten of the most recent destinations to make them available for route guidance. A new destination automatically overwrites the oldest destination.

Selecting the destination and starting the navigation system

1. Tap  .
2. Tap on the desired destination.
3. Tap Route.

Quick start

1. Tap  .
2. Tap and hold the preferred destination for a few seconds.



Favorite destinations

You can save up to 50 journey destinations as favorites.



Saving a journey destination as a favorite

1. While entering a destination, tap on  in the additional window.

Selecting the destination and starting the navigation system

1. Tap  .
2. Tap on the desired destination.
3. Tap Route.

Quick start

1. Tap  .
2. Tap and hold the preferred destination for a few seconds.

Selecting on the map

The navigation map contains active areas at many points which are suitable for the input of a destination. To enter a destination, tap on your preferred position or preferred location on the map. If map data is available at this point, you can launch route guidance.

Entering a destination via the navigation map is dependent on data status and not possible for all positions.



Use the Offroad navigation system to enter a destination to a selected destination point with unknown data.

Offroad navigation

The Offroad navigation system calculates routes to selected destinations with unknown data. If the destination is not located on a known road or at a known position, the navigation system will calculate the route up to the next point on the known road and then complete the route to the destination using a straight line.

In order to start an Offroad navigation, tap on a free area without positioning data.



Starting the navigation

1. Tap .
2. Press and slide the map view until you can select your desired position. You can operate the navigation map using extended finger touches ⇒  [Introduction](#).
3. Tap the preferred destination or any destination point on the map without positioning data.
4. Tap Route.

Using a contact's address data

Start route guidance via the saved address data for a contact. You cannot use contacts for whom you have not saved any address data for route guidance.

Starting the navigation

1. Tap  .
2. Tap on the preferred contact and address data.
3. Tap Route.

NOTICE

If the address data for your contact is out of date, the route guidance will nevertheless direct you to the stored address. Please ensure the address for your

contact is up to date.

Navigation data

 Please read the introductory information and heed the Warnings and Notice ⇒  and  Safety instructions.

The Infotainment system is equipped with an internal navigation data storage medium. Depending on the country, the required navigation data may already be installed.

The Infotainment system always requires up-to-date navigation data to ensure that route guidance can be implemented correctly and that the functions provided are fully available.

NOTICE

If you use outdated navigation data, there may be adverse effects on the navigation system. It may not be possible to determine up-to-date routes, or route guidance may guide you to an incorrect destination.

- Always ensure that your navigation data is kept up-to-date.

Updating navigation data online

Navigation data for frequently visited regions is automatically updated in the background when the ignition is switched on and there is an active Internet connection

1. Switch the ignition on.
2. Check the Internet connection, if necessary.

Navigation data for frequently visited regions is automatically updated in the background.

 Automatic updates to navigation data depend on the country.

Updating navigation data manually

Up-to-date navigation data for larger regions, such as Western Europe, can be downloaded online at www.volkswagen.com and stored on a suitable USB data carrier, available to buy in stores. If the Infotainment system is switched off during the process, installation will be interrupted and it will continue automatically once the system is turned on again.

1. Download and save the navigation data onto a USB data storage device.
2. Switch the vehicle ignition on.
3. Link the USB data carrier to the Infotainment system when the vehicle is stationary.

The navigation data for frequently driven regions is automatically updated in the background.

 While and after updating the navigation data, no message appears in the Infotainment system.

 If you update the navigation data manually, the USB data carrier must remain permanently connected. You will not receive a notification when the update is complete.

 Do not disconnect the USB data carrier from the Infotainment system for a few days until the navigation data for visited regions has been fully downloaded and installed. The installation will start automatically in the background during the journey. Doing so will cancel the update process. If you disconnect the data carrier and visit a new region, the navigation data is not updated due to the lack of a USB data carrier.

Displaying the map data version

1. Tap **(HOME)** ▶  ▶ System information.
Or: tap **(MENU)** ▶  ▶ System information.

Mobile phone interface

Introduction

Using the phone interface, you can connect your cell phone to the Infotainment system and control the phone functions via the Infotainment system. The sound is played back via the vehicle speakers.

You can connect up to two cell phones to the Infotainment system at the same time. However, only one device is active at a time and can be used to make calls. The second connected device can receive calls via the Infotainment system and be used to play media.

High speeds, poor weather and road conditions, a lot of background noise, even outside the vehicle, and the network quality can impair phone calls in the vehicle.

The phone interface may contain an antenna amplifier that improves the reception quality of the cell phone.

 You generally only need to pair a device like a cell phone once. You can reestablish the device's connection to the Infotainment system at any time via Bluetooth or Wi-Fi without re-pairing your device.

 For a phone call via the hands-free system or at a high volume, a conversation may also be heard by third parties outside the vehicle.

Opening the phone interface menu

1. Tap **(HOME)** ▶ .

Or: tap .

Or: press .

Opening the settings

1. Tap or .

Or: Tap .

Or: Press and tap .

Functions and symbols of the phone interface

Refer to and *Safety instructions*.

The named functions and symbols may differ depending on the vehicle equipment and are not available in all countries. The available functions depend on the cell phone used and its operating system.

Functions

- Hands-free system.
- Use up to two cell phones simultaneously.
- Phonebook with up to 5000 contact entries.
- SMS functions via Bluetooth:
 - Read SMS.
 - Write SMS, inc. templates.
 - Have an SMS read out.
 - Message thread.
- E-mail functions via Bluetooth:
 - Read e-mail.
 - Write e-mail.
- Convenience telephony *Types of phone interface*.
- Connection to cable-free charging option (cable-free charging function) *Wireless charging function*.
- Connection to in-vehicle microphone.

Symbols in the main menu

The symbols may look different depending on the Infotainment system.

Open contact list. Open incoming and outgoing calls lists. Dial telephone number. Open messages (SMS and, depending on your country, e-mail). Change active device. Open phone interface settings.

Symbols for telephone calls

The symbols may look different depending on the Infotainment system.

Handle and display a call. End or decline a call. Mute the hands-free system. Put a call on hold. Continue a call. Add participants to a phone conference or begin a phone conference. Make an emergency call (SOS). Receive breakdown assistance. Voice mail. Receive information about Volkswagen and various value added traffic and travel services.

Call list symbols

1. To open the call lists, tap on .

Received incoming call. Outgoing call. Missed call. Frequent calls or favorites from your cell phone, if supported by your cell phone. Telephone number (company). Telephone number (private). Mobile telephone number. Fax device. Fax device (company). Fax device (private).

Text message symbols

The symbols may look different depending on the Infotainment system.

1. To open the text messages, tap on .

Template for text messages. Have text messages read out.

Locations with special regulations

Refer to and *Safety instructions*.

Switch off the cell phone and phone interface at locations where there is a risk of explosions. These locations are not always clearly identified. These include, for example:

- Areas near pipes and tanks containing chemicals

- Lower decks in ships and ferries
- Areas near vehicles powered by liquefied petroleum gas, such as propane and butane.
- Areas with chemicals or particles in the air, such as flour, dust, or metal powder
- All other locations where the engine or the cell phone must be switched off.

⚠ WARNING

Switch off the cell phone and phone interface at locations where there is a risk of explosions and locations with specific regulations.

ⓘ NOTICE

The cell phone must always be switched off in areas with special regulations relating to or prohibiting the use of cell phones. Radiation from cell phones that are switched on can interfere with sensitive technical and medical devices, potentially causing malfunctions or damage to the devices.

Types of phone interface

📖 Refer to ⇒ ⚠ and ⓘ *Safety instructions.*

Depending on the country and vehicle equipment, your vehicle may have the following mobile phone interfaces:

- Phone interface basic configuration.
- Convenience phone interface.

Phone interface basic configuration

The phone interface uses the HFP Bluetooth profile for transmission. This enables the use of phone functions via the Infotainment system and played back via the vehicle speakers.

Convenience phone interface

Just like the basic configuration of the phone interface, the Convenience phone interface uses the HFP Bluetooth profile.

The Convenience phone interface can be equipped with the wireless charging function ⇒ *Wireless charging function.*

In order to use the features of the wireless charging function, you need to place a suitable cell phone correctly in the storage compartment. Depending on the vehicle equipment, this will connect the cell phone to the vehicle antenna. This improves reception and call quality.

Wireless charging function

📖 Refer to ⇒ ⚠ and ⓘ *Safety instructions.*

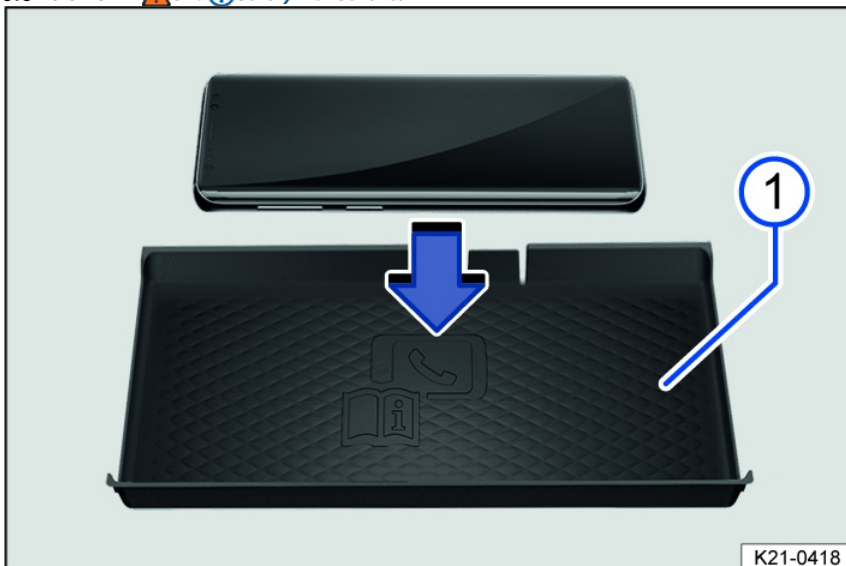

Fig. 136 Diagram: storage compartment with a liner pad for wireless charging.

The wireless charging function depends on the vehicle equipment and is not available in all countries.

Depending on the vehicle, the rear shelf with liner mat *fig. 136* for the wireless charging function is located in the center console or between the front seats in a storage compartment.

In some vehicles, the liner mat bears a phone symbol, which indicates the center position for the wireless charging function *fig. 136*. The symbol on the liner mat may look different in some vehicles.

The wireless charging function uses electromagnetic induction to transfer energy wirelessly over short distances.

The maximum charging power is 5 watts.

The Qi standard allows suitable Qi-capable cell phones to be charged wirelessly.

To find out whether a cell phone supports the Qi standard, see the cell phone operating instructions. The manufacturer of the cell phone can offer further information regarding compatibility.

Only a single Qi-capable cell phone without a protective case and with maximum dimensions (width x length) of approximately 3 in x 6 in (80 mm x 140 mm) should ever be placed flat on the wireless charging function shelf.

Qi-capable cell phones with larger dimensions cannot be charged wirelessly.

Before charging, remove any foreign objects with metal components, such as coins, from the storage compartment and follow the cell phone operating instructions.

To charge a Qi-capable cell phone, place a suitable cell phone, without a protective case and with the display and the entire surface facing up, flat in the center of the shelf. The charging process starts automatically.

The Infotainment system installed at the factory informs you when the charging process is starting and, if necessary, if there are any foreign objects with metal components in the storage compartment. Remove foreign objects immediately.

If a cell phone is not placed on the shelf correctly or if it is too large, it may not be detected correctly or detected at all. The Infotainment system may notify you of a foreign object in the storage compartment. If a suitable cell phone is used and its position is corrected, the fault may be eliminated.

Storage compartment cover

Depending on the vehicle equipment and in some countries, the storage compartment for the wireless charging function may have a cover for the cell phone display.

Only a cell phone with maximum dimensions (width x length) of approximately 3 in x 6 in (80 mm x 140 mm), in accordance with the specifications, may be placed in the covered storage compartment.

The cover can prevent you from being distracted by the cell phone, e.g. by incoming notifications.

The cover must always be closed while driving and the display of the cell phone must be completely covered up.

WARNING

Notifications on the display of the cell phone may distract the driver and increase the risk of a serious accident.

- Place only a single, suitable and Qi-capable (if necessary) cell phone without a protective case and with maximum dimensions (width x length) of approximately 3 in x 6 in (80 mm x 140 mm), in accordance with the specifications, on the shelf in the storage compartment.
- If necessary, remove items that prevent the cover from closing.
- Always keep the cover closed while driving.

WARNING

Metal objects can become very hot. This may cause burns to the skin or a fire.

- Do not place metal objects or objects with metal components on the wireless charging shelf.

NOTICE

Do not place any ID cards, credit cards, etc. with magnetic strips or with a chip on the wireless charging shelf. The data stored on the magnetic strips or the chip could become unusable.

Coupling, connecting and managing

 Refer to  and  *Safety instructions*.

To use the phone interface functions, pair a cell phone capable of making phone calls with the Infotainment system. Before connecting for the first time, you need to pair the cell phone with the Infotainment system. A user profile is then automatically saved in the Infotainment system. The coupling process may take a few minutes.

Pairing a cell phone

Prerequisites for coupling:

- ✓ Bluetooth is activated on the cell phone.
- ✓ Bluetooth is activated on the Infotainment system.

1. Open the list of available Bluetooth devices on your cell phone and select the device name for the Infotainment system.
2. Pay attention to messages on the cell phone and in the Infotainment system and confirm these if necessary.

If the pairing is successful, the data on the cell phone will be saved in the user profile.

3. Optional: Confirm the message for transferring the data on the cell phone.

WARNING

If you carry out the coupling when driving, this may cause accidents or injuries.

- Only carry out the coupling when the vehicle is stationary.

 **When pairing some cell phones, a PIN may be displayed on the cell phone screen. Type this PIN into the Infotainment system to finish pairing.**

Active and passive connection

In order to use the phone interface functions, at least one cell phone must be connected to the Infotainment system. If several cell phones are connected to the Infotainment system, you can switch between an active and an inactive connection. In order to operate the phone interface with your preferred cell phone, establish an active connection to the Infotainment system.

Difference between the types of connection

ActiveThe cell phone is paired and connected. You can carry out phone interface functions using data from this cell phone. **Passive**The cell phone is paired and connected. You can only take incoming calls via the mobile phone interface. Other functions are not available.

Paired cell phones are saved in the Infotainment system even if they are not currently connected.

Change connection type (inactive to active)

Precondition:

- ✓ Several cell phones are connected to the Infotainment system simultaneously.

1. Tap .

Or: tap on the name for the active cell phone.

The actively connected cell phone is highlighted.

2. Tap the name for the preferred cell phone.

The connection with the other cell phones will be inactivated automatically.

User profiles

An individual user profile is automatically created for each paired cell phone. Data from this cell phone, e.g. contact data, is stored in the user profile. A maximum of ten user profiles may be saved in the Infotainment system simultaneously.

To delete the stored data completely, reset the Infotainment system to the factory settings.

Calling and sending messages

 Refer to   and  **Safety instructions.**

Using a phone

Select a telephone number to make a call. Various functions are available for selecting the telephone number.

Using contact data

If a contact has multiple telephone numbers, you must select the number you wish to call accordingly.

1. Tap .

Or: tap . Tap and enter the name of the contact in the input field to search for the contact.

Or: To call a favorite, tap Favorites in the main menu of the phone interface.

2. Tap on a contact in the list to make the call.

 **When searching for a contact, enter the last name and first name separated by a space.**

Using a call list

The phone interface displays the call list for the cell phone. Make a call via the call list.

1. Tap   All. Tap on a number in the list to make the call.

Or: Tap  and filter entries in the call list, e.g. by missed calls. Tap a number on the filtered list to make the call.

Manually entering the telephone number

1. Tap  and enter a telephone number.



2. Tap  to make the call.

 **While you are entering a telephone number, the contact related to the number is displayed on the Infotainment system screen.**

Sending text messages

Depending on the cell phone and the Infotainment system in use, you can send and receive SMS messages and, depending on your country, e-mails via the phone interface.

Sending an SMS

1. Tap   SMS  New message and enter the message on the screen.

2. Enter the desired contact in the search bar.
3. Tap OK to send the message.

Sending an e-mail

1. Tap  E-MAIL ► New message and enter the message on the screen.
2. Enter the desired contact in the search bar.
3. Tap OK to send the message.

Phone directory, favorites and speed dial keys

 Refer to   and  [Safety instructions](#).

Phonebook

This first time a cell phone is paired with the Infotainment system, the phonebook is saved in the Infotainment system. If necessary, confirm the transfer on the cell phone.

The phone directory is updated after each new connection. During the update, the present phone directory can still be used.

If teleconferences are supported, the phonebook can be opened during a phone call and another participant can be added to the phone call.

If an image is stored for the contact, it can be displayed in the list next to the entry.

The symbols may look different depending on the Infotainment system.

Favorites and speed dial keys

A speed dial key can be assigned with a favorite from the phone directory. If the entry contains an image, it is displayed on the speed dial key.

Speed dial keys must be programmed manually and are assigned to a user profile  [Coupling, connecting and managing](#).

Programming a speed dial key

1. Tap a free speed dial key.
2. Tap a contact in the phone directory or search for it using the search bar. If a contact has multiple telephone numbers, tap a number on the list.

Editing the speed dial key

1. Tap and hold the speed dial key until the phonebook opens.
2. Tap the new contact in the phone directory. If a contact has multiple telephone numbers, tap a number on the list.

Calling a favorite

1. Tap a programmed speed dial key.

 **Favorites are not automatically updated. If the phone number for a contact changes, the speed dial key must be reassigned.**

Deleting a favorite from the speed dial key

1. Tap   ► Manage favorites.

To delete a favorite, tap the preferred speed dial key .

Or: tap  .

Or: to delete all favorites from all speed dial keys, tap Delete all.

2. Tap confirm to delete the data.

Voice control

Introduction to using voice control

With voice control, you can have certain functions carried out by voice command.

Types of voice control

Depending on which language has been set in the Infotainment system, one of the following voice controls will be available in the vehicle:

- Command-based voice control (standard).
- Enhanced voice control (offline or online).

Does my vehicle have voice control?

If there is a Talk button  on the multi-function steering wheel or the  button is available in the Infotainment system or your vehicle understands the activation word, voice control is installed in the vehicle.

 **In black with blue background: Voice control is active and recognizes spoken words.**

 **Test voice control before a journey to get to know the function.**

Differences in the voice controls

Command-based voice control (standard)

Only grammatically correct voice commands are recognized by the voice control. Voice commands must follow a fixed syntax in order to be recognized correctly, e.g. "Navigate to [city, street name, house number]". You can find further examples in the Infotainment system. The command-based voice control can be carried out in any available language.

Enhanced voice control (offline or online)

Speech commands can be freely worded in common speech. For example, in response to the question "How long is left to drive?", the system gives the remaining time until arrival at the destination. Suggestions for voice commands depend on the set language and can be found in the Infotainment system.

Enhanced voice control works both online and offline. By evaluating voice commands, online mode offers improved POI, media and online radio station search functionality. Additionally, messages can be dictated. For online mode, you need a VW Car-Net contract valid for the vehicle.

 If enhanced voice control is available in your language, it is used to activate voice control.

Supported languages

The number of languages available in your country depends on the vehicle equipment.

Start voice control by saying the activation word available in your country ⇒ *Activation word*.

Starting and ending voice control

Voice commands

Voice control only recognizes voice commands in the language selected in the infotainment system.

Observe the following tips for successful voice commands:

- ✓ Speak clearly and at normal volume. Speak a little louder at higher speeds.
- ✓ Avoid excessive emphasis and strong accents.
- ✓ Do not leave long pauses in speech.
- ✓ Avoid external and background noise.
- ✓ Do not direct the air flow from the vents towards the microphone or headliner.

Open suggestions for speech commands



1. Tap **HOME** ►  ► .

 To ensure that names in the phonebook are identified correctly, you may need to switch the order of the first and last names of the desired contact, depending on how the phonebook entry is structured.

Starting voice control



You can use different methods to start voice control, depending on the vehicle equipment:

- Start speaking: Say the activation word ⇒ *Activation word*.
- Start via multi-function steering wheel: Press the Talk button .
- Starting up via the Infotainment system: Tap on **VOICE**.

 Depending on the cell phone and operating system, voice control of a connected cell phone can be started by pressing and holding  or the **VOICE** button ⇒ *App-Connect*.

Ending voice control

You can use different methods to end voice control, depending on the vehicle equipment:

- Finish speaking: To open suggestions for a voice command to cancel, tap **HOME** ►  ►  ► General.
- End via the multi-function steering wheel: press the Talk button .
- End automatically: If you use functions within the Infotainment system, activate the parking system; if telephone calls or tasks involving speech and navigation warnings occur, the voice control ends automatically.

Activation word

In the ring memory of the Infotainment system, the words spoken in the vehicle are checked for the activation word. If the Infotainment system detects the activation word, voice control will begin. A ring memory is automatically overwritten approximately every 15 seconds. There is no transmission of data or words spoken in the vehicle. The ring memory is inactive when the activation word is switched off.

Switching activation word on and off

If the activation word is switched off, voice control cannot be activated via the activation word.

1. Tap **(MENU)** ►  ► Voice control ► Voice control start/end sound or Activation word.

Speaking and recognizing the activation word

Precondition:

- ✓ The Activation word is switched on in the settings.

(CDN) Bonjour Volkswagen. **(MEX)** Hola Volkswagen. **(USA)** Hello Volkswagen.

Troubleshooting

Voice control is not responding

- Voice control is not available in your language.
- Set the correct system language in the Infotainment system.
- Start voice control by using the activation word or the Talk button on the multi-function steering wheel.
- Voice commands are not recognized due to a system error. Contact suitably qualified professionals for assistance. Volkswagen recommends contacting an authorized Volkswagen dealer or authorized Volkswagen Service Facility.

Voice control is giving unsuitable responses

- Voice control has misinterpreted the question.
- Clearly give your voice command again.

Voice control is not performing the function

- This function cannot be performed by voice control.
- The function is not available in all languages. You can find suggestions for voice commands in the set language in the Infotainment system.
- Settings within the function are preventing the device from switching on or carrying out the function.
- Voice control did not understand the voice command.
- There is insufficient data.

Transporting

Stowing luggage and cargo

Stowing luggage securely in the vehicle

- Distribute luggage as evenly as possible in the vehicle. Do not cover any vent openings.
- Always stow luggage and heavy objects in the luggage compartment and place them as far forward in the compartment as possible ⇒ .
- Adhere to the Gross Axle Weight Rating and Gross Vehicle Weight Rating ⇒ [Technical data](#).
- Secure objects in the luggage compartment using suitable securing cords, fixation belts or tensioning straps on the tie-downs.
- Also store small objects securely.
- If necessary, fold the rear seat backrest down and lock it securely.
- If necessary, adjust the headlight range. Vehicles with dynamic headlight range control will adjust automatically.
- Adjust the tire pressure based on the load. Follow the tire pressure label ⇒ [Tire pressure](#).
- If necessary, calibrate the Tire Pressure Monitoring System (TPMS) to the new load ⇒ [Tire Pressure Monitoring Systems](#).

WARNING

Objects or animals that are not secured or are secured incorrectly can cause serious injuries in the event of sudden driving and braking maneuvers or a collision. This is especially true if the airbags deploy and strike objects, causing them to fly through the vehicle interior. To reduce the risk of damage, note the following:

- Store all objects securely in the vehicle. Follow the legal regulations whilst doing so.
- Stow objects in the vehicle interior in such a way that they will not enter the airbag deployment zone while you are driving.
- Secure animals in the vehicle restraint systems that are appropriate for their weight and size.
- Always keep the storage compartments closed while driving.
- Never stow objects in a location that requires you to adjust any seats to an incorrect seating position.
- If stowed objects block a seat, then no one should use this seat.
- Do not leave hard, heavy, or sharp objects loose in the open storage compartments in the vehicle, on the surface behind the rear seat backrest, or on the instrument panel.
- Remove hard, heavy, or sharp objects from clothing and bags in the vehicle interior and store them securely.

WARNING

When transporting heavy objects, the vehicle's handling performance may change because of the altered center of gravity and the braking distance may increase. If not stored or secured correctly, heavy objects can cause you to lose control of the vehicle and cause serious injuries.

- Never overload the vehicle. Both the load and the distribution of the load in the vehicle affect driving behavior and braking efficiency.
- When transporting heavy objects, the vehicle handling performance may change due to the shift in the center of gravity.
- Always distribute the load evenly and as low down in the vehicle as possible.
- Secure heavy objects in the luggage compartment as far in front of the rear axle as possible.
- Loose objects in the luggage compartment can slide around suddenly and alter the vehicle handling.
- Always adapt your speed and driving style to the visibility, weather, road and traffic conditions.
- Accelerate with extra care and caution.
- Avoid sudden braking or driving maneuvers.
- Apply the brakes earlier than usual.

NOTICE

Abrasive objects on the rear windows can cause damage, for example to the heating elements for the rear window defroster.

NOTICE

Do not attach a luggage rack or any other kind of carrying system, e.g. bicycle rack, to the vehicle's rear spoiler.

Luggage compartment cover

Luggage compartment cover

When opening and closing the trunk lid, the luggage compartment cover is raised or lowered on the attached retaining straps.

The luggage compartment cover is not suitable for use as storage for objects, even lightweight items of clothing ⇒ ⚠.

⚠ WARNING

Objects or animals on the luggage compartment cover can damage the luggage compartment cover and cause serious injuries in the event of sudden driving and braking maneuvers or an accident.

- Never transport objects on the luggage compartment cover.
- Never allow animals to ride on the luggage compartment cover.

ⓘ NOTICE

Incorrect handling of the luggage compartment cover can cause damage.

- Do not load the luggage compartment so high that the luggage compartment cover presses on the load when the trunk lid is closed.
- Never close the trunk lid while the luggage compartment floor is open or locked.

Installing and removing the luggage compartment cover

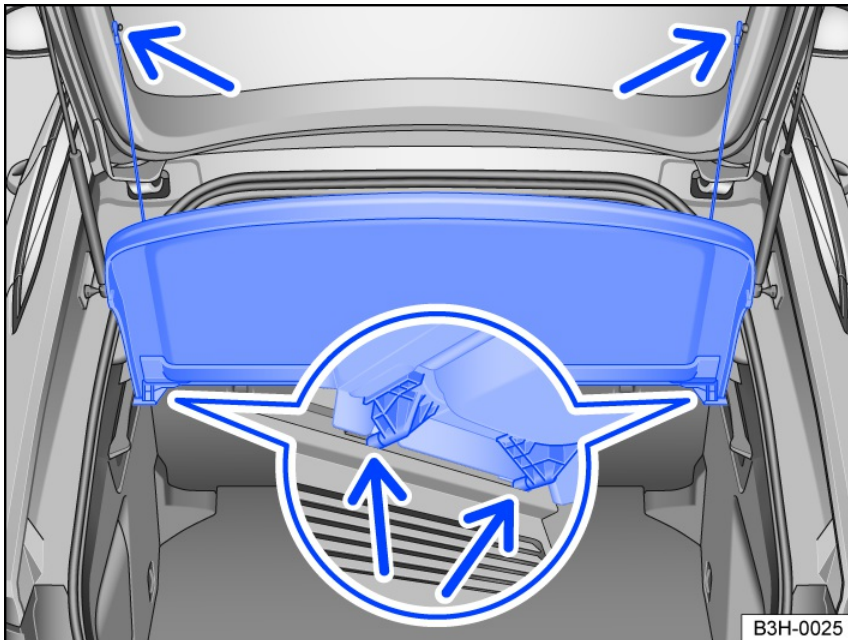

Fig. 137 In the luggage compartment: Installing and removing the luggage compartment cover.

Removing the luggage compartment cover

1. Unhook the top retaining straps from the trunk lid *fig. 137* (upper arrows).
2. Lift the trunk lid.
3. Press the luggage compartment cover out of the lateral brackets in the luggage compartment *fig. 137* (lower arrows).

Installing the luggage compartment cover

1. Press the luggage compartment cover into the side holders in the luggage compartment *fig. 137* (lower arrows).
2. Hook the retaining straps onto the trunk lid *fig. 137* (upper arrows).

Luggage compartment floor

Luggage compartment floor - functions

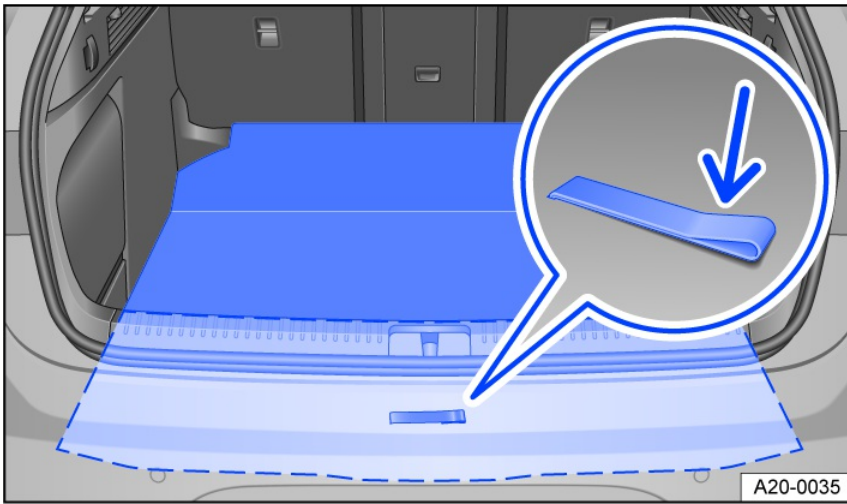

Fig. 138 In the luggage compartment: opening the luggage compartment floor.

Opening the luggage compartment floor

1. Lift the luggage compartment floor onto the loop *fig. 138* (small arrow).

Closing the luggage compartment floor

1. Guide the luggage compartment floor downward by the loop *fig. 138* (small arrow) and lay it down in the luggage compartment.

Removing the luggage compartment floor

1. Hold the loop on the luggage compartment floor *fig. 138* (small arrow) and remove the luggage compartment floor from the luggage compartment.

Store the luggage compartment floor somewhere clean and dry.

Installing the luggage compartment floor

1. Place the luggage compartment floor carefully back into the luggage compartment with the loop on the upper sider *fig. 138* (small arrow).

! NOTICE

Improper use may damage the luggage compartment floor or the luggage compartment trim.

- When closing the luggage compartment floor, always carefully guide it downward, and do not drop it.
- Always distribute loads as evenly as possible across the entire luggage compartment floor to avoid concentrating the load in a single place.

Reversible floor mat



Fig. 139 In the luggage compartment: Turning over the reversible floor covering.

The reversible floor covering can be used to ensure that the luggage compartment floor is suitable for whatever is being placed on it.

Turning over the reversible floor covering

1. Lift the back edge of the reversible floor covering in the direction of the arrow *fig. 139*.
2. Turn over the reversible floor covering and position it on the luggage compartment floor.

Luggage compartment features

Storage compartments in the luggage compartment

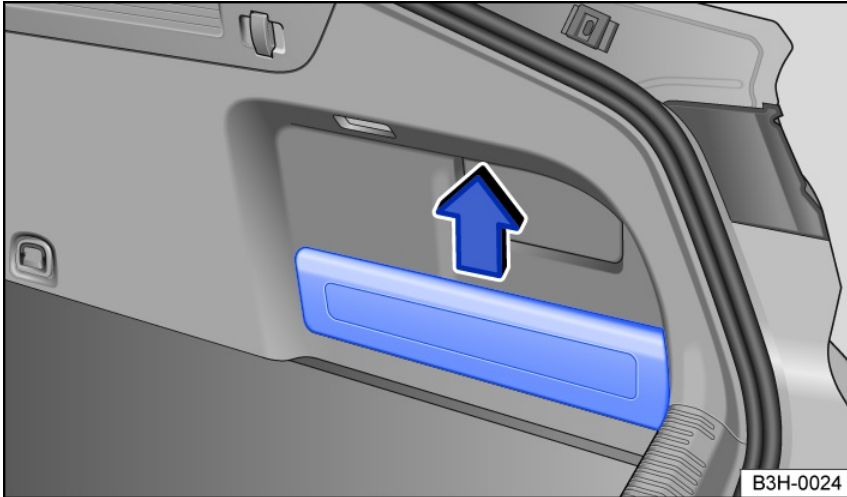

Fig. 140 In the luggage compartment: Storage compartment at the side with side panel.

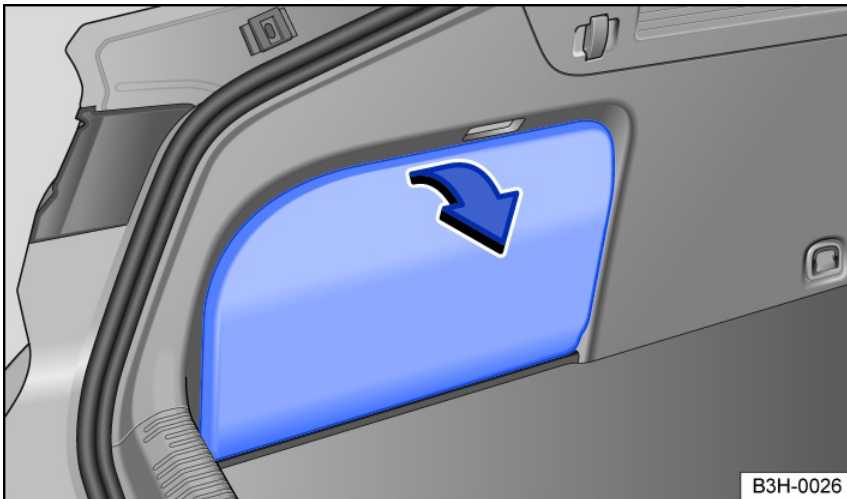

Fig. 141 In the luggage compartment: Side storage compartment with cover.

Removing the storage compartment with side panel

Storage compartments can be found at the side of the luggage compartment.

The side panel can be removed so that larger items can be stored in the luggage compartment.

1. Lift out the side panel in the direction of the arrow *fig. 140*.

Installing the storage compartment with side panel

1. Insert the side panel in the opposite direction to the arrow *fig. 140*.

Opening the storage compartment with cover

In the side of the luggage compartment there may be a stowage compartment with a cover.

Depending on the vehicle equipment, the 12 V vehicle battery may be installed in the stowage compartment → *12 V vehicle battery*.

1. Pull the cover in the direction of the arrow *fig. 141*.

Closing the storage compartment with cover

1. Push the cover in the opposite direction of the arrow *fig. 141* until it engages.

Tie-downs

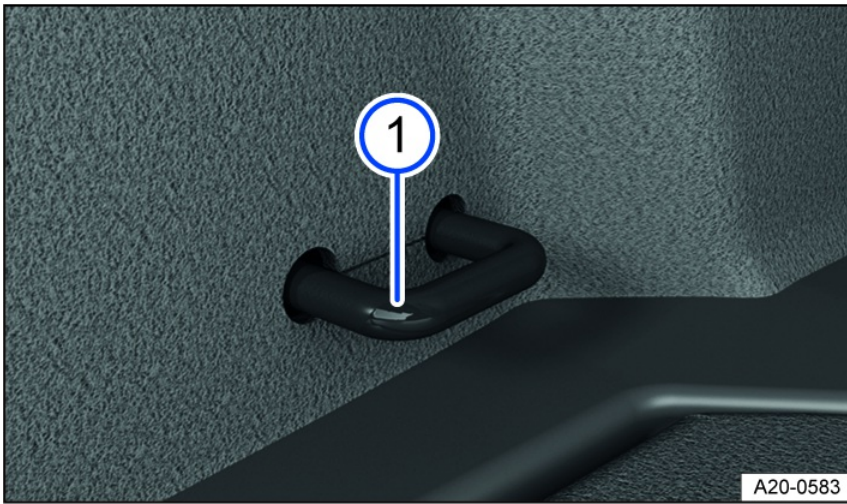

Fig. 142 In the luggage compartment: Tie-down (general example).

① Tie-down.

Tie-downs are located in the luggage compartment to secure loose objects and luggage with the help of lines, fixation belts or securing straps *fig. 142*.

⚠ WARNING

Unsuitable or damaged tie-down straps or tensioning straps could break during braking maneuvers or an accident. This could result in objects being thrown through the vehicle interior and causing serious or fatal injuries.

- Use only suitable and undamaged tie-downs, fixing and tensioning straps.
- Secure cords, fixation belts and tensioning straps diagonally and tightly across the items placed on the luggage compartment floor, and fasten the cords, fixation belts and tensioning straps securely to the tie-downs.
- Make sure that the upper edge of the load is above the tie-downs, especially on flat objects.
- Depending on the vehicle equipment, follow any signs about storing cargo in the luggage compartment.
- Never secure a child restraint to the tie-downs.

⚠ WARNING

Elastic tensioning straps must be stretched for securing to the tie-downs. The hooks attached to them can cause serious injuries.

- When securing elastic tensioning straps, always protect your eyes and face from injury.
- When securing, always hold the elastic tensioning straps securely so that they cannot slip off and rebound.
- Always secure elastic tensioning straps to the tie-downs in the front part of the luggage compartment first, then pull them to the loading edge and secure them to the tie-downs there. If the tensioning straps slip they will spring away from your body.

i Suitable straps and cargo securing systems are available from an authorized Volkswagen dealer or authorized Volkswagen Service Facility. Volkswagen recommends contacting an authorized Volkswagen dealer or authorized Volkswagen Service Facility.

Shopping bag hooks



Fig. 143 In the luggage compartment: fold-out shopping bag hooks.

You may have shopping bag hooks in your luggage compartment for hanging light shopping bags.

⚠ WARNING

Loose objects can be thrown around the inside of the vehicle during sudden driving or braking maneuvers. This can cause serious injuries and loss of vehicle control.

- Never use the shopping bag hooks to tie down pieces of luggage or objects. The shopping bag hooks could break during sudden braking maneuvers or in the event of an accident.
- Only hang lightweight items, up to a maximum of 2.5 kg (approximately 5.5 lbs), from the shopping bag hooks in the vehicle.

Load-through hatch

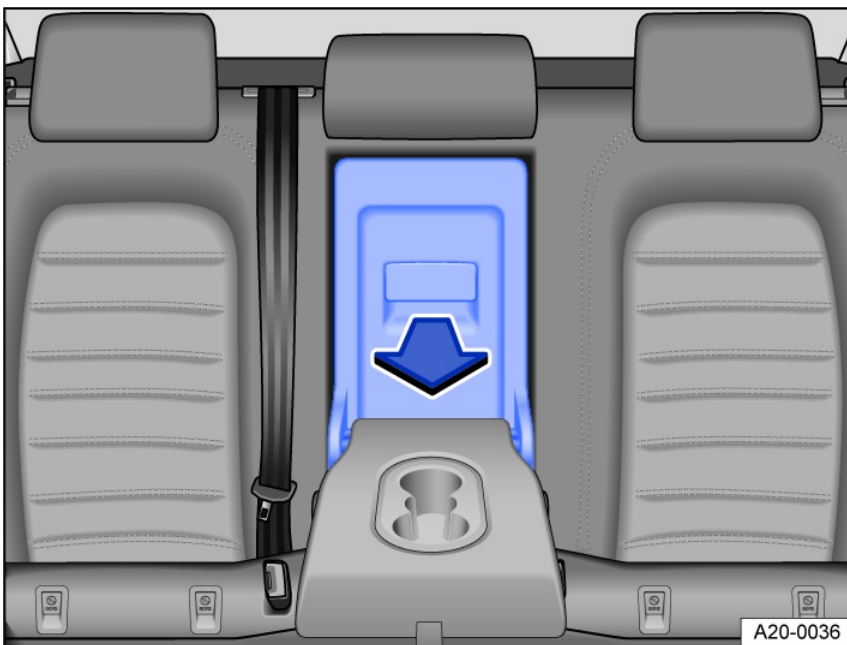

Fig. 144 Pass-through in the rear seat backrest.



Fig. 145 Pass-through in the luggage compartment.

Depending on the vehicle equipment, there may be a load-through hatch behind the center armrest in the rear seat backrest for transporting long objects, such as skis, inside the vehicle.

Opening the pass-through from the vehicle interior

1. Fold the center armrest forward ⇒ *Center armrest*.
2. Pull the release lever in the direction of the arrow *fig. 144* and fold the luggage compartment pass-through cover all the way forward ⇒ ⚠.
3. Open the trunk lid.

Opening the pass-through from the luggage compartment

1. Press the release lever down in the direction of the arrow *fig. 145* and fold the cover forward.
2. Insert long objects from the luggage compartment side and slide them forward through the load-through hatch.
3. Secure objects with a seat belt if necessary.
4. Close the trunk lid.

Closing the load-through hatch

1. Fold the flap for load-through hatch backward until it audibly engages.
There may be a red mark on the luggage compartment side. This should not be visible ⇒ ⚠.
2. Close the trunk lid.
3. If necessary, fold the center armrest backward.

⚠ WARNING

Folding and unfolding the load-through hatch in an uncontrolled or careless manner may cause severe injury.

- Never fold the luggage compartment pass-through forward or back while driving.
- When folding up the pass-through, make sure that the safety belt does not become trapped or damaged.
- Keep hands, fingers, feet and other body parts away from the pivot range of the pass-through when folding it forward or back.
- If a red mark is visible on the locking display, the luggage compartment pass-through may not be engaged. Always check that the red mark is not visible when the pass-through is in the upright position.
- If the load-through hatch is folded down or not properly engaged, no passengers, especially children, are to be transported on this seat.

Trailer towing

📖 Introduction

If equipped correctly, the vehicle can be used to tow a trailer. The increased weight from towing affects vehicle wear, fuel consumption, and vehicle performance and may shorten the service intervals.

Driving a trailer not only increases the vehicle load, but requires more concentration from the driver.

Vehicles with a start/stop system

Before trailer towing using towing brackets which have not been retrofitted by Volkswagen, the start/stop system must be manually deactivated and remain deactivated during the entire trailer towing process → *Start-stop system*.

Trailer with function check for the lighting

No trailer with tail lights and brake lights that require a function check for the tail light or brake light in order to be approved may be operated on this vehicle. Please consult the trailer manufacturer to find out what approval applies to your trailer.

Unused ball mount

Swivel the ball mount or remove it if there is no trailer, bicycle rack or similar attached to the ball mount. This is especially applicable if the vehicle's license plate or lighting is obscured by the unused ball mount. Note the country-specific regulations for using a ball mount → .

Special conditions

Before driving with a trailer, please note that the functions of the assistance and parking systems may be limited.

DANGER

Transporting persons in a trailer can cause life-threatening injuries and may be against the law.

- Never transport anyone in a trailer.

WARNING

Using the trailer hitch incorrectly can result in loss of control of the vehicle, accidents, and serious injuries.

- Install and use the trailer in accordance with the instructions provided by the corresponding manufacturer.
- Only use the ball mount if it is undamaged and secured correctly.
- Do not modify or repair the ball mount.
- To reduce the risk of injury during a rear collision and to pedestrians and cyclists near parked vehicles, always swivel in or remove the ball mount when you are not towing a trailer.
- Never install "weight distributing" or "load equalizing" ball mounts. The vehicle was not designed for these types of trailer hitches. The trailer hitch could malfunction and the trailer could disconnect from the vehicle.

WARNING

Driving with a trailer and transporting heavy or large objects can change the vehicle handling performance, increase the braking distance, and cause accidents.

- Always secure cargo correctly with suitable and undamaged cords, fixation belts or tensioning straps.
- Always adapt your speed and driving style to the visibility, weather, road and traffic conditions. Reduce the vehicle speed, especially when driving downhill.
- Trailers with a high center of gravity may tip sooner than trailers with a low center of gravity.
- Always drive carefully and try to anticipate what may be ahead. Accelerate with extra care and caution. Avoid abrupt and sudden driving and braking maneuvers.
- Be very careful when passing. Reduce vehicle speed as soon as you detect the slightest swaying movement in the trailer.
- Do not drive faster than 50 mph (80 km/h), or 60 mph (100 km/h) if absolutely necessary, when towing a trailer. This also applies in countries where higher speeds are permitted. Adhere to the applicable local maximum speed limit, which may be lower for vehicles towing a trailer than it is for vehicles that are not towing a trailer.
- Never try to "straighten out" a swaying trailer by accelerating.

WARNING

When towing with towing brackets which have not been retrofitted by Volkswagen the start/stop system must always be manually deactivated. Otherwise this can lead to a failure in the brake system and can cause accidents and severe injury.

 If you have integrated a trailer into the anti-theft alarm system, breaking the connection to the trailer may trigger the anti-theft alarm system → *Anti-theft alarm system*.

 Do not tow a trailer during the first 1000 km (600 miles) driven with a new engine → *Breaking in the engine*.

 Some retrofitted trailer hitches cover the mount for the towing eye. If this is the case, it will not be possible to use the towing eye to tow other vehicles. Because of this, you should always keep the ball mount from a retrofitted trailer hitch inside the vehicle when it is removed.

Hitching a trailer

 Please read the introductory information and heed the Warnings and Notice ⇒  and  Introduction.

Trailer socket

If the trailer has a 7-pin connector, a suitable adapter must be used.

1. Lift the socket cap and insert the plug.
2. Rotate the plug clockwise by a quarter of a rotation until it fully engages into the socket.
3. Release the cap to lock the plug in place.
4. Check that the entire lighting system is working properly before starting the journey.

If you are not sure how to connect the trailer with the towing vehicle's electrical system correctly, consult an authorized Volkswagen dealer or authorized Volkswagen Service Facility. Volkswagen recommends contacting an authorized Volkswagen dealer or authorized Volkswagen Service Facility.

Safety chains

Always make sure that the safety chains are correctly secured on the vehicle. The safety chains require sufficient play and can sag, but should not touch the ground.

Integrating into the anti-theft alarm system

The trailer is integrated into the anti-theft alarm system if the following requirements are met:

- ✓ If the vehicle is equipped with a factory-installed anti-theft alarm system and trailer hitch.
- ✓ If the trailer is connected to the electrical system in the towing vehicle.
- ✓ If the vehicle and trailer electrical systems are functioning correctly and are not damaged.
- ✓ If the vehicle was locked using the vehicle key and the anti-theft alarm system is active.

When the vehicle is locked, the alarm will be triggered if the electrical connection to the trailer is disconnected.

Trailers with LED taillights cannot be integrated into the anti-theft alarm system due to the technology involved.

When the vehicle is locked, the alarm will not be triggered if the electrical connection to the trailer with LED taillights is disconnected.

WARNING

Improperly or incorrectly connected electrical wires can electrify the trailer and lead to malfunctions in the entire vehicle electrical system as well as accidents and serious injuries.

- Have all work on the electrical system performed only by an authorized Volkswagen dealer or authorized Volkswagen Service Facility. Volkswagen recommends contacting an authorized Volkswagen dealer or authorized Volkswagen Service Facility.
- Never connect the electrical system on a trailer to the electrical connectors for the taillights or other power sources on the towing vehicle.

WARNING

Contact between the pins on the trailer socket can cause short circuits, overloading of the electrical system, or malfunction of the lighting system, which can result in accidents and serious injuries.

- Never connect the pins in the trailer socket to one another.
- Have bent pins repaired only by an authorized Volkswagen dealer or authorized Volkswagen Service Facility. Volkswagen recommends contacting an authorized Volkswagen dealer or authorized Volkswagen Service Facility.



NOTICE

A trailer that is resting on a supporting wheel or on the trailer support should not remain hitched to the vehicle. Changes to the load or tire damage may raise or lower the vehicle. This would put great stress on the trailer hitch and the trailer, which could lead to damage to the vehicle and trailer.

 If the engine is stopped and accessories on the trailer are on while there is an electrical connection through the trailer socket, then the 12 V vehicle battery will drain.

 The electrical connection to the trailer will be automatically disconnected if the charge level of the 12 V vehicle battery becomes too low.

Loading a trailer

 Please read the introductory information and heed the Warnings and Notice ⇒  and  Introduction.

General information

Always ensure that the vehicle and trailer are well balanced. Do not load the trailer unevenly by putting more weight at either the front or the back. Always store heavy objects as close as possible to or above the axle. Always secure the load on the trailer properly ⇒ .

Trailer load and tongue weight

The trailer load is the weight that the vehicle can tow.

The trailer tongue weight rating is the load that presses down vertically from above onto the ball mount of the trailer hitch.

Volkswagen recommends always using the maximum permissible trailer tongue weight rating ⇒ *Technical data*. Tongue weight that is too low affects the trailer's handling. The maximum permissible trailer tongue weight rating of the trailer drawbar on the trailer hitch ball head must not be exceeded ⇒ .

The actual trailer tongue weight rating increases the weight on the rear axle and reduces the possible load in the vehicle.

In some countries, under certain conditions, a higher trailer tongue weight rating can be used. Follow the local specifications and regulations.

Towing weight

The towing weight consists of the actual weights of the loaded towing vehicle and the loaded trailer.

In some countries, trailers are divided into classes. Volkswagen recommends consulting with an authorized Volkswagen dealer or authorized Volkswagen Service Facility about suitable trailers. Volkswagen recommends contacting an authorized Volkswagen dealer or authorized Volkswagen Service Facility.

Tire pressure

The tire pressure for the tires on the trailer is based on the recommendation of the trailer manufacturer.

When towing a trailer, inflate the tires on the towing vehicle to the maximum permissible tire pressure ⇒ *Tire pressure*.

WARNING

Sliding loads can considerably impair driving stability and trailer safety and increase the risk of accidents and serious injuries.



- Always load trailers correctly.
- Always secure cargo with suitable and undamaged cords or tensioning straps.

WARNING

If the Gross Axle Weight Rating, tongue weight, Gross Vehicle Weight Rating, or towing weight of the vehicle and the trailer are exceeded, accidents and serious injuries can result.

- Never exceed the specified values ⇒ *Technical data*.
- Never exceed the maximum Gross Axle Weight Rating on the front or rear axle. Never exceed the maximum Gross Vehicle Weight Rating for the front and rear weight of the vehicle.

Driving with a trailer

 Please read the introductory information and heed the Warnings and Notice ⇒  and  *Introduction*.

Headlight adjustment

When a trailer is attached, the front part of the vehicle may be lifted, and the dipped beam headlights may dazzle other road users. Lower the beam corresponding using the headlight range control. Vehicles with dynamic headlight range control adjust automatically and do not need to be manually adjusted.

Characteristics when driving with a trailer



- When driving with a trailer with an overrun brake, first brake gently then rapidly. This avoids braking jolts due to the trailer wheels locking.
- The braking distance increases due to the gross combination weight (of the trailer and vehicle).
- Use the engine as an additional brake on slopes. Otherwise the brake system may overheat and possibly fail.
 - Vehicles with an automatic transmission: Select a lower gear when driving in Tiptronic mode.
- The vehicle's center of gravity, and thereby also its driving characteristics, are changed by the towing weight and the increased total weight of the vehicle and trailer.
- An empty towing vehicle and loaded trailer create a very unfavorable weight distribution. Drive very carefully and slowly with this combination.

Driving on hills with a trailer

Depending on the angle of the hill and the total weight of the trailer, a parked trailer may roll back slightly when you start driving.

When towing a trailer, start on a hill as follows:

1. Press and hold the brake pedal.
2. Press the  button once to switch off the electronic parking brake.
3. Vehicles with an automatic transmission: Engage the gear to drive forward.

4. Pull and hold the  button to hold the vehicle and trailer with the electronic parking brake.
5. Release the brake pedal.
6. Start driving slowly.
7. Only release the  switch once the engine has created enough drive power to start driving.

⚠ WARNING

Towing a trailer incorrectly can result in loss of control of the vehicle and cause serious injuries.

- Driving with a trailer and transporting heavy or large objects can change the vehicle handling performance and increase the braking distance.
- Ensure sufficient visibility behind you. Attach additional rearview mirrors if rear visibility is impaired due to the trailer. Volkswagen recommends the use of Volkswagen original parts or Volkswagen original accessories, which you can acquire from an authorized Volkswagen dealer or authorized Volkswagen Service Facility.
- Always drive carefully and try to anticipate what may be ahead. Brake earlier than usual.
- Always adapt your speed and driving style to the visibility, weather, road and traffic conditions. Reduce the vehicle speed, especially when driving downhill.
- Accelerate with extra care and caution. Avoid abrupt and sudden driving and braking maneuvers.
- Take particular care when overtaking. Reduce vehicle speed as soon as you detect the slightest swaying movement in the trailer.
- Never try to “straighten out” a swaying vehicle and trailer by accelerating.
- Adhere to the applicable local maximum speed limit, which may be lower for vehicles towing a trailer than it is for vehicles that are not towing a trailer.

Trailer hitch

Ball mount holder

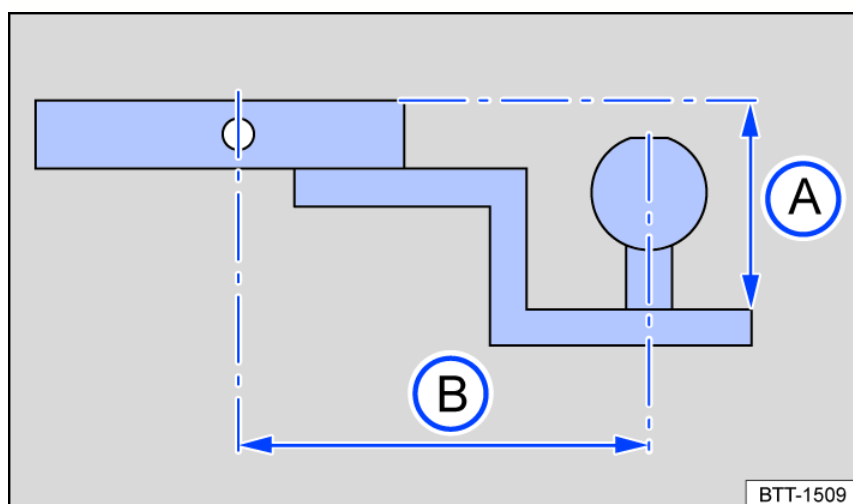

Fig. 146 Dimensions of the ball mount holder and receptacle.

- A** Suspended height of the ball mount.
- B** Distance between socket pin and ball mount.

To pull a trailer you must have installed the necessary cabling, including a socket, and the corresponding trailer hitch. Since pulling a trailer represents a heavy strain for the vehicle towing it, connecting the trailer to the towing vehicle and correct dimensions for the receptacle and the ball mount holder are extremely important in order for the towing vehicle to cope with the strain to be placed on it.

The mount requires a special shape and size of ball mount holder and ball mount. This affects both the suspended height of the ball coupling [fig. 146 A](#) and the distance between the socket pin and the ball coupling [fig. 146 B](#).

These dimensions determine the distribution of strain on the receptacle and the connections to the vehicle during towing. When purchasing a ball mount holder and a ball mount, always ensure that these will cope with the requirements.

Dimensions of the ball mount holder

- The drop height [fig. 146 A](#) from the top edge of the ball mount to the top edge of the neck must not exceed 40.6 mm (1 ³⁹/₆₄ inches).
- The distance between the socket pin and the ball mount [fig. 146 B](#) must not exceed 157.5 mm (6 ¹³/₆₄ inches) from the middle of the ball mount to the middle of the eye of the pin.
- The diameter of the ball mount may not exceed 50.8 mm (2 inches).

Ball mounts and holders which do not meet these specifications could damage your car or could fail completely ⇒ .

Securing cables

In some countries, unbraked and braked trailers must be secured by means of securing or breakaway cables.

Follow the country-specific regulations for using a securing cable.

1. Secure the securing or breakaway cable to the provided ball mount eyelet.
2. Guide the cable through the eyelet and hook it in the karabiner ⇒ .

WARNING

Incorrect mounting or the use of an incorrect trailer hitch can lead to the trailer becoming detached from the towing vehicle during the journey, potentially causing serious accidents and injuries.

- Only have work on your trailer hitch or the retrofitting of a trailer hitch carried out by an authorized Volkswagen dealer or authorized Volkswagen service facility. Volkswagen recommends contacting an authorized Volkswagen dealer or authorized Volkswagen Service Facility.

WARNING

An improperly secured trailer can cause accidents and injuries.

- Never drape the securing or breakaway cable of the trailer loosely over the ball mount.

CAUTION

Always remove the ball mount holder when you do not require it, in order to reduce the risk of injuries in a rear-end collision.

NOTICE

Fitting an unsuitable ball mount can cause vehicle damage and invalidation of the operating license.

- Use the ball mount supplied by the factory or a ball mount approved for your vehicle model and its model year.
Volkswagen recommends the use of Volkswagen original parts or Volkswagen original accessories, which you can acquire from an authorized Volkswagen dealer or authorized Volkswagen Service Facility.

NOTICE

- Your vehicle was not designed to tow trailers requiring larger ball heads than those specified. Never use ball mounts with a diameter that exceeds 50.8 mm (2 inches).
- Never use an adapter in order to use a larger ball mount.
- If necessary, you may use an adapter to enable you to mount a bicycle carrier or similar. Always observe the weight specifications when doing so. These should never cover your tail lights.

Retrofitting a trailer hitch

Volkswagen recommends having a trailer hitch retrofitted by an authorized Volkswagen dealer or authorized Volkswagen Service Facility. For example, modifications to the cooling system or installation of heat shields may be necessary. Volkswagen recommends contacting an authorized Volkswagen dealer or authorized Volkswagen Service Facility.

Mount the trailer hitch in accordance with the instructions supplied.

A retrofitted, non-removable trailer hitch must not cover the label or the lighting system on the rear of the vehicle. Note the country-specific regulations for using a ball mount ⇒ .

WARNING

Improperly or incorrectly connected electrical wires can lead to malfunctions in the entire vehicle electrical system as well as accidents and serious injuries.

- Never connect the electrical system on a trailer directly to the electrical connectors for the taillights or other unsuitable power sources. Only use suitable connectors to connect the trailer.
- If retrofitting the vehicle with a trailer hitch, have the work performed by an authorized Volkswagen dealer or authorized Volkswagen Service Facility. Volkswagen recommends contacting an authorized Volkswagen dealer or authorized Volkswagen Service Facility.

WARNING

A trailer hitch that is installed incorrectly or that is not suitable for the vehicle can lead to the trailer separating from the vehicle that is towing it. This can cause

accidents and fatal injuries.

i Only use trailer hitches that are provided for the vehicle model, model year and vehicle equipment by the corresponding manufacturer. Volkswagen recommends the use of Volkswagen original parts or Volkswagen original accessories, which you can acquire from an authorized Volkswagen dealer or authorized Volkswagen Service Facility.

Roof rack

i Introduction

Depending on the model, the vehicle may be designed to have a roof rack installed.

Bulky objects can be transported on the vehicle roof using the roof rack.

If you are not sure if your vehicle is designed to have a roof rack installed, check with an authorized Volkswagen dealer or authorized Volkswagen Service Facility. Volkswagen recommends contacting an authorized Volkswagen dealer or authorized Volkswagen Service Facility.

Only use roof racks that are approved by Volkswagen for use with your vehicle.

Do *not* use or retrofit a roof rack if this is *not* approved for your vehicle.

⚠ WARNING

When transporting heavy or large objects on the roof rack, your vehicle's driving characteristics could change because of the different center of gravity or increased wind resistance.

- Always secure cargo correctly with suitable and undamaged cords, fixation belts or tensioning straps.
- Large, heavy, long, or flat objects can have a negative effect on the vehicle's aerodynamics, center of gravity, and handling.
- Avoid abrupt and sudden driving and braking maneuvers.
- Always adapt your speed and driving style to the visibility, weather, road and traffic conditions.

⚠ WARNING

If a roof rack that is *not* approved for the vehicle is installed or a roof rack is installed on a vehicle that is *not* designed for using a roof rack, accidents and serious injuries can occur.

- Only use roof racks that are approved by Volkswagen for the vehicle.
- Never install a roof rack on a vehicle that is not approved for using a roof rack.
- If a roof rack is not approved but is installed anyway, the rack could come loose while driving and fall off the roof.

! NOTICE

Installing any type of roof rack on a vehicle where this is *not* approved can cause serious vehicle damage.

i Driving with a roof rack fitted increases the air resistance of the vehicle and thus also the fuel consumption. This reduces the potential range of the vehicle. This applies to all roof racks and any objects transported on them, such as bicycles and skis.

Mounting a roof rack

i Please read the introductory information and heed the Warnings and Notice ⇒ **⚠** and **!** Introduction.

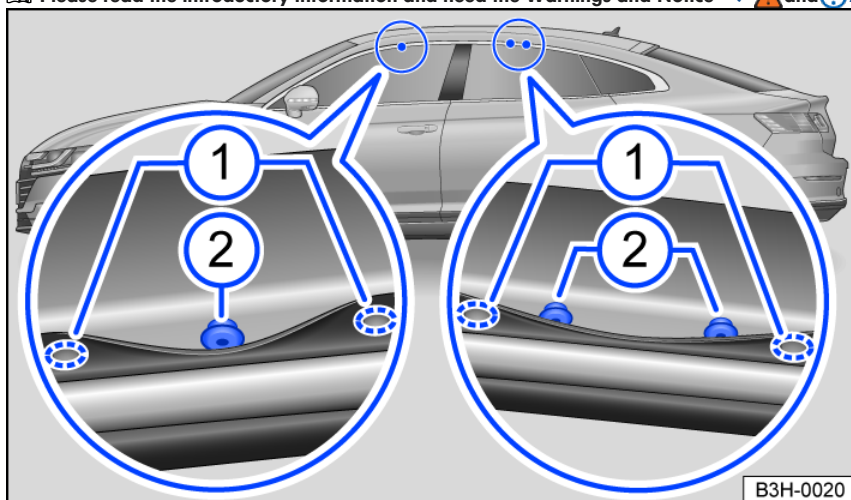

Fig. 147 Mounting points for base supports.

- ① Marks for base supports.
- ② Mounting points for base supports.

For safety reasons, special roof racks are needed to transport luggage, bicycles, surfboards, skis and boats safely.

Only use roof racks that are provided for the vehicle model, model year and vehicle equipment by the corresponding manufacturer.

Volkswagen recommends the use of Volkswagen original parts or Volkswagen original accessories, which you can acquire from an authorized Volkswagen dealer or authorized Volkswagen Service Facility.

Mounting a roof rack (vehicles without roof rail)

Mount the roof rack in accordance with the instructions supplied.

The holes or markings for securing the roof rack can only be seen when the doors are open. If necessary, unscrew the plastic screw from the hole opening.

The front holes or markings are located on the undersides of the roof pillars near the door seal.

The rear holes or markings are located on the undersides of the roof pillars near the door seal or, depending on the vehicle equipment, at the top of the rear side windows.

After the roof rack has been mounted, the rack base can now be secured to it ⇒ ⚠.

Remove the roof rack in the following scenarios

- If the roof rack is no longer needed.
- Before driving through an automatic car wash
- If the height of the vehicle exceeds the maximum height limit, for example in a garage

! NOTICE

- The height of the vehicle changes when a roof rack is installed and when there is cargo secured on it. Compare the height of the vehicle with height clearances, for example for underpasses and garage doors.
- Parts on the roof of your particular vehicle (depending on the vehicle equipment), e.g. the roof antenna, and the trunk lid's range of movement must not be impaired by the roof rack and the luggage.

⚠ WARNING

Securing the roof rack and base incorrectly or using them incorrectly can cause the cargo or the entire assembly to come loose from the vehicle roof, which can cause accidents and injuries.

- Only use the roof rack and base if they are undamaged and secured correctly.
- Always mount the roof rack and base correctly. Always observe the assembly instructions provided by the manufacturer.
- Secure the roof rack only at the locations intended for this.
- Always mount special rack assemblies for bicycles, skis, surfboards, etc. correctly. Always observe the assembly instructions provided by the manufacturer.
- Check the roof rack mounts before starting a journey and, if necessary, retighten them after a short distance. On long trips, check the threaded connections and fasteners each time you take a break.
- Do not make any modifications or repairs to the roof rack or base.

🍃 A fitted roof rack increases air resistance and therefore may reduce the vehicle's range.

Loading the roof rack

📖 Please read the introductory information and heed the Warnings and Notice ⇒ ⚠ and ! Introduction.

Maximum permissible roof weight

The maximum permissible roof load is 100 kg (220 lbs).

The roof load consists of the weight of the roof rack and the items carried on the roof rack → ⚠.

Always check the weight of the roof rack and the items that will be transported on it. Weigh the items if necessary.

When using a roof rack with a low load limit, do not load the rack with the maximum permissible roof load. In this case, only load the roof rack to the weight limit list in the installation guide.

Distributing the load

Distribute the load evenly and secure it correctly → .

Checking that everything is secure

Once you have fitted the roof rack, drive a short distance and then check all the fasteners. Keep checking them regularly.

WARNING

Accidents and serious injuries can result if the maximum permissible roof weight is exceeded.

- Never exceed the specified roof load, the Gross Axle Weight Rating, and the Gross Vehicle Weight Rating of the vehicle.
- Do not exceed the load limit of the roof rack, even if the roof load is below the limit.

WARNING

Items that are secured loosely or incorrectly could fall off the roof rack and cause accidents and injuries.

- Use only suitable and undamaged tie-downs, fixing and tensioning straps.

NOTICE

Make sure the trunk lid does not run into the roof load when opening the lid.

Fuel and emissions control system

Safety precautions for handling fuel

⚠ WARNING

Handling fuel incorrectly can cause explosions, fires, severe burns, and other injuries.

- Before refueling, switch off the engine, the ignition and your cell phone, as well as other radio equipment.
- To reduce the risk of discharging static electricity, do not enter the vehicle while refueling.
- Make sure that the fuel tank cap is sealed correctly and no fuel is leaking out.
- Note the applicable safety precautions and local regulations for handling fuel.

⚠ WARNING

Refueling incorrectly can cause fires, serious injuries, and vehicle damage.

- Only use fuel that is approved for your vehicle.
- Do not use any fuels containing metal and only use service additives approved by Volkswagen in the respective proportion.
- Immediately remove any fuel that has spilled on vehicle components.

⚠ CAUTION

Fuel may leak out of reserve canisters. This can cause fires and injuries.

- Do not transport any reserve canisters in the vehicle.

🌿 Fuels can contaminate the environment. Collect any leaking operating fluids and dispose of them according to legal regulations.

🔧 The fuel filler flap does not have an emergency release. If necessary, contact an authorized Volkswagen dealer or authorized Volkswagen Service Facility for assistance.

Fuel types and refueling

📖 Introduction

The fuel filler flap is located on the right rear side of the vehicle.

Designation of fuels and fuel standards

📖 Refer to ➡ ⚠ and ⚠ *Safety precautions for handling fuel.*



Fig. 148 On the inside of the fuel filler flap: fuel label (general example)

Fuel label

The type of fuel to use depends on the vehicle engine. When your vehicle leaves the factory there is a fuel information sticker inside the tank flap with notes about the minimum required fuel type for your vehicle *fig. 148*.

The name specifies which fuels are suitable for the vehicle. This is a minimum requirement ➡ ⚠.

Fuel standards

The fuel used must meet one of the following standards. The vehicle must not be refueled with other fuels ⇒ .

If fuel with the specified standards is not available, contact suitably qualified professionals for information about which fuels are suitable for the vehicle. Volkswagen recommends contacting an authorized Volkswagen dealer or authorized Volkswagen Service Facility.

Gasoline

Gasoline and methanol mixture

- AKI 87 or higher.
- Maximum 3% methanol.

Gasoline and ethanol mixture

- AKI 87 or higher.
- Maximum 15% ethanol.

Gasoline and MTBE mixture

- AKI 87 or higher.
- Maximum 15% MTBE.

NOTICE

Refueling with non-standard and non-approved fuels can cause reduced performance and considerable damage to the engine and the fuel system.

- Before refueling, check if the fuel specification at the fuel pump meets the vehicle specifications.
- Only refuel using fuels that conform to the specified standards and name to reduce the risk of damage to the fuel system and engine malfunctions.

Gasoline

 Refer to ⇒  and  *Safety precautions for handling fuel.*

Gasoline types

The gasoline types differ in terms of their AKI (Anti-Knock Index) specification, which is given from the formula $(RON + MON)/2$, or the Research Octane Number (RON) specification. The vehicle may also be fueled with gasoline that has a higher AKI or RON than what is required by the engine. However, this will not improve fuel consumption or engine power.

Arteon, Atlas 2.0 and Jetta GLI: Volkswagen recommends using premium-grade fuel with AKI 91 or ROZ 95 in order to achieve the specified power and torque.

The fuel information label may have multiple gasoline types, for example AKI 93 min. 91. The highlighted gasoline type, AKI 93 in this example, is the preferred gasoline type for which the vehicle is designed and optimized. The listed alternative gasoline type, AKI 91 in this example, should only be used if the preferred type AKI 93 in this example, is not available.

If your vehicle has a gasoline engine, fuel it only with gasoline that does not contain any metal (no lead, manganese or iron) ⇒ .

The most frequently purchased gasoline types in the USA and Canada have the following octane values, which are normally listed on the fuel pump:

- Regular (normal gasoline): AKI 87 to 90 or ROZ 91.
- Premium (super gasoline): AKI 91 to 93 or ROZ 95.

Volkswagen recommends using "TOP TIER Detergent Gasoline", which is available in some regions, for example North America, Central America and South America. For more information on "TOP TIER Detergent Gasoline", visit the official website at:

<http://www.toptiergas.com>

NOTICE

Using gasoline that does not meet the minimum octane number requirements may reduce engine performance, while the use of poor-quality gasoline or gasoline with an AKI of below 87 or a ROZ of under 91 could also result in engine damage.

Refueling

 Refer to ⇒  and  *Safety precautions for handling fuel.*



Fig. 149 Behind the fuel filler flap: fuel tank cap (general example)

Refueling procedure

1. To unlock the fuel filler flap, unlock the vehicle with the  button on the remote control vehicle key ⇒ *Vehicle key functions*.

Or: to unlock the fuel filler flap, unlock the vehicle with the  button in the driver door ⇒ *Central locking button*.

On vehicles with Keyless Access, the fuel filler flap is automatically unlocked when the vehicle is unlocked.

2. Open the fuel filler flap.

3. Remove the fuel tank cap and insert it into the opening at the fuel filler flap provided for this *fig. 149*.

4. Hold the fuel pump nozzle handle down to ensure optimum refueling.

The fuel tank is full once the fuel pump nozzle turns off for the first time ⇒ .

5. Screw the fuel tank cap onto the fuel filler neck.

6. Close the fuel filler flap.

Do not continue filling after disconnection. The expansion area in the fuel tank may fill with fuel, e.g. due to heating. This may mean that the fuel overflows or the automatic ventilation process cannot work ⇒ *Troubleshooting*.

WARNING

Fuel may spray out and overflow if the fuel tank is overfilled. This can cause explosions, fires, and serious injuries.

- Do not continue filling after the pump nozzle switches off for the first time.

NOTICE

Every six months, if possible, run the fuel tank empty until the indicator light comes on and refuel it. This is required to maintain the system functions and fuel quality necessary for operation.

 Fuels can contaminate the environment. Collect any leaking operating fluids and dispose of them according to legal regulations.

Exhaust system

Introduction

The exhaust-relevant components reduce exhaust emissions:

- Catalytic converter ⇒ *Catalytic converter*.
- Particulate filter (depending on the vehicle equipment) ⇒ *Particulate filter*.

WARNING

Engine exhaust contains carbon monoxide, which can cause loss of consciousness and death.

- Do not allow the engine to run in confined spaces.
- Never start the engine in confined spaces.
- Do not leave your vehicle unattended while the engine is running.

WARNING

Exhaust system components will become very hot. This can cause fires.

- Park the vehicle in such a way so that no exhaust system components come into contact with flammable materials under the vehicle such as brush, leaves, dry grass, etc.
- Never use additional underbody protection or corrosion protection on exhaust pipes, catalytic converters, particulate filters or heat shields.

Catalytic converter

 Please read the introductory information and heed the Warnings and Notice ⇒  and  *Safety precautions for handling fuel.*

To ensure that the exhaust system and the engine catalytic converter can work correctly for a long time, observe the following:

- Only refuel with fuel permitted for the vehicle.
- Never drive until the fuel tank is completely empty ⇒ *Refueling.*
- Never add too much engine oil ⇒ *Checking the engine oil level and adding oil.*
- Do not tow-start the vehicle; use jump-start assistance instead ⇒ *Preparing and Performing a Jump-start.*

If there are engine misfires, loss of power, or poor engine operation while driving, reduce the speed immediately and have the vehicle checked by suitably qualified professionals ⇒ *Troubleshooting.* Volkswagen recommends contacting an authorized Volkswagen dealer or authorized Volkswagen Service Facility. Otherwise, uncombusted fuel could be present in the exhaust system and then enter the atmosphere. The catalytic converter may also be damaged from overheating.

 The exhaust may smell like sulfur when the emissions control system is running correctly.

Particulate filter

 Please read the introductory information and heed the Warnings and Notice ⇒  and  *Safety precautions for handling fuel.*

Function

The particulate filter (depends on how your vehicle is equipped) filters out soot from the exhaust gas.

Regeneration

With normal vehicle usage, the filter cleans itself. If the filter is unable to clean itself, e.g. if you only make short trips for an extended period of time, the filter can become blocked with soot. The particulate filter needs to be cleaned (regenerated).

Noises, light odors, and increased engine speeds may occur during the regeneration. The radiator fan may continue to run while driving and after turning off the engine.

To assist in particulate filter regeneration, Volkswagen recommends avoiding driving short distances too frequently.

 The soot in the particulate filter is burned periodically at high temperatures. The yellow  indicator light does not turn on during a periodic regeneration.

Troubleshooting

 Please read the introductory information and heed the Warnings and Notice ⇒  and  *Safety precautions for handling fuel.*

If the engine does not run smoothly and malfunctions

If the engine does not run smoothly or malfunctions while driving, it can indicate poor fuel quality.

1. Reduce your speed immediately.
2. Drive with a moderate RPM and low engine load to the nearest suitably qualified professional. Volkswagen recommends contacting an authorized Volkswagen dealer or authorized Volkswagen Service Facility.
3. If these symptoms occur directly after refueling, stop the engine immediately to prevent subsequent damage.
4. Contact an authorized Volkswagen dealer or authorized Volkswagen Service Facility for assistance.

Particulate filter clogged with soot

The yellow indicator light turns on.

The particulate filter is clogged with soot and a regeneration is necessary.

Prerequisite for the regeneration drive: The engine is at operating temperature.

For gasoline engines

1. Drive at a speed of at least 50 mph (80 km/h).
2. Take your foot completely off the accelerator pedal for a few seconds to let the vehicle roll with a gear engaged.
3. Repeat this process of accelerating and letting the vehicle roll until the indicator light turns off.
4. If the indicator light does not turn off after some time, immediately consult an authorized Volkswagen dealer or authorized Volkswagen Service Facility.

Volkswagen recommends contacting an authorized Volkswagen dealer or authorized Volkswagen Service Facility.

Exhaust-related malfunction

The yellow indicator light turns on.

An exhaust-related component is malfunctioning, which could damage the vehicle.

1. Contact a suitably qualified professional and have the engine and the exhaust system checked. Volkswagen recommends contacting an authorized Volkswagen dealer or authorized Volkswagen Service Facility.

Misfire

The indicator light flashes yellow.

There is misfire which could damage the vehicle.

1. Contact a suitably qualified professional and have the engine and the exhaust system checked. Volkswagen recommends contacting an authorized Volkswagen dealer or authorized Volkswagen Service Facility.

WARNING

If you perform driving maneuvers that other road users cannot anticipate, you may cause an accident.

- Always adapt your speed and driving style to the visibility, weather, road and traffic conditions.
- Follow the road traffic laws and regulations that apply in the country you are driving in.

 **If the indicator lights are on or flashing, it is likely that there is an engine malfunction and that fuel consumption will increase.**

Do it yourself

Vehicle tool kit

Introduction

When securing the vehicle in the event of a vehicle breakdown, follow the legal regulations applicable in the respective country.

⚠ WARNING

A vehicle tool kit, tire mobility set, spare tire, or compact spare tire that is loose or not secured correctly can be thrown around the vehicle interior during sudden driving or braking maneuvers or in a collision and cause serious injuries.

- Always make sure the vehicle tool kit, tire mobility set, and spare wheel or compact spare wheel are secured in the luggage compartment.

⚠ WARNING

An unsuitable or damaged vehicle tool kit can cause accidents and injuries.

- Never work with an unsuitable or damaged vehicle tool kit.

Placement

📖 Please read the introductory information and heed the Warnings and Notice ⇒ ⚠ Introduction.

There are a number of different storage locations for the tool box in the vehicle, such as under the luggage compartment floor or in a side storage compartment of the luggage compartment.

Depending on the equipment variant, the vehicle may contain a loose box with the vehicle tool kit in the luggage compartment. This supplemental vehicle tool kit is designed for a possible winter tire change and does not need to be carried in the vehicle at all times → page , *Stowing luggage and cargo* .

🔧 If used, crank the vehicle jack back down so that it can be securely stowed in the vehicle.

Vehicle tool kit components

📖 Please read the introductory information and heed the Warnings and Notice ⇒ ⚠ Introduction.

The scope of the tool box depends on the country and equipment. In some countries, there may also be a tire pressure gauge in the vehicle. The following information describes the full scope of items that may be included.

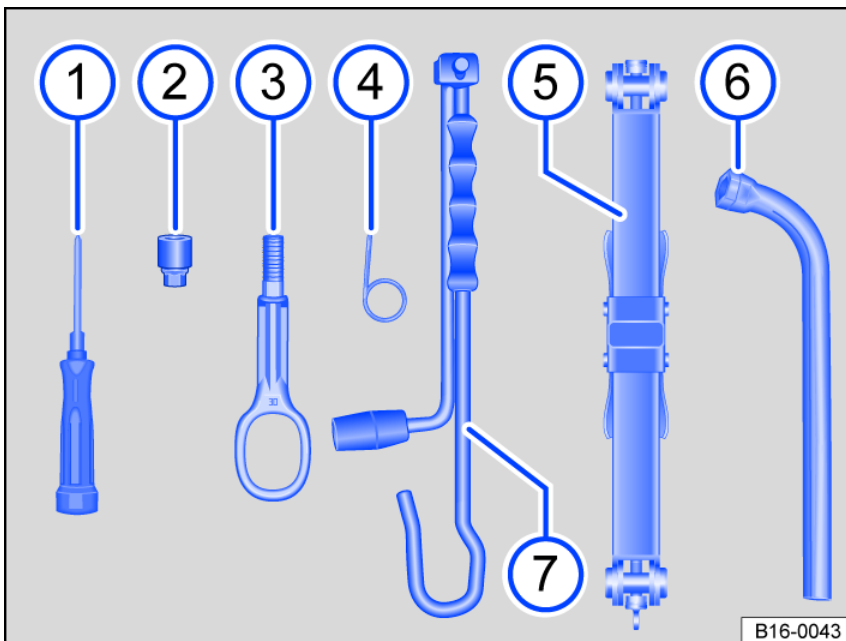

Fig. 150 Vehicle tool kit components (general example).

- 1 Screwdriver with hex socket in the handle for removing or installing loose wheel bolts. The screwdriver blade is reversible. The screwdriver may be located under the lug wrench.
- 2 Adapter for the anti-theft wheel bolt. Volkswagen recommends always keeping the adapter for the wheel bolts in the vehicle with the vehicle tool kit. The code number for the wheel bolt lock is stamped on the front of the adapter. A replacement adapter can be ordered based on this number if the adapter is lost. Note the wheel bolt lock code number and keep it separate from the vehicle.
- 3 Towing eye that can be screwed in.

- ④ Extraction hook for removing the center wheel covers, wheel hub covers, or wheel bolt covers.
- ⑤ Vehicle jack. Before putting the vehicle jack away, crank the vehicle jack claw all the way down.
- ⑥ Lug wrench.
- ⑦ Crank.

Jack maintenance

Generally, the vehicle jack does not need any maintenance.

1. If necessary, apply universal lubricant to the jack.

Windshield wipers

Putting the windshield wipers in the service position

In the service position, the wiper arms can be lifted off of the windshield.



Fig. 151 Windshield wipers in service position (general example).

Activate the service position using the windshield wiper lever

1. Close the hood, driver and front passenger door.
2. Switch the ignition off and on again.
3. Briefly press the windshield wiper lever towards “one-tap wiping” ⇒ *Operating the windshield wiper lever*.

Lifting the windshield wiper arms

1. Move the windshield wiper arms into the service position before lifting ⇒ .
2. Only hold and lift wiper arms in the area where they attach to the wiper blade.

Placing the windshield wiper arms back

1. Carefully place the wiper arms back in position before driving, and only hold the wiper arms in the area where they attach to the wiper blade.
2. When the ignition is switched on, press the windshield wiper lever briefly towards “one-tap wiping”.

The wiper arms move back to the original position.

NOTICE

Improper lifting and placing of wiper arms can damage the engine hood, windshield and wiper arms.

- Lift the wiper arms only in the service position.
- Always place the wiper arms against the windshield before driving.

Cleaning and changing wiper blades

Wiper blades with a graphite coating are installed at the factory. The graphite coating allows the wiper blade to glide easily over the window. A damaged graphite coating creates an increased noise level when wiping the window.

Check the condition of the wiper blades regularly. If wiper blades are rubbing, replace them if they are damaged or clean them if they are dirty ⇒ .

Damaged wiper blades should be replaced immediately. Wiper blades can be obtained from suitably qualified professionals. Volkswagen recommends contacting an authorized Volkswagen dealer or authorized Volkswagen Service Facility.

Cleaning the wiper blades

Windshield wiper: Move the windshield wiper arms into the service position before lifting.

1. Lift the wiper arms, making sure to only hold the wiper arms in the area where they attach to the wiper blade.
2. Clean the wiper blades carefully with a damp sponge ⇒ ⚠.
3. Place the wiper arms carefully on the windshield.

Changing the windshield wiper blades

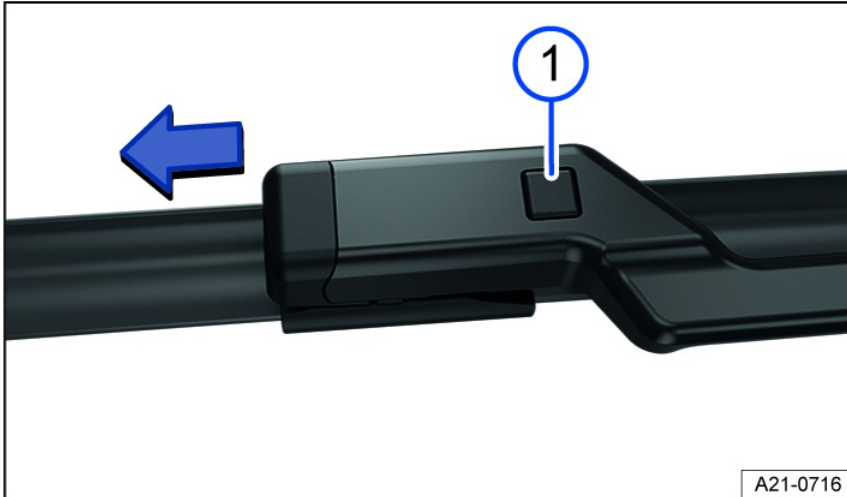

Fig. 152 Changing the windshield wiper blades.

ⓘ Unlock button of the wiper blade.

1. Move the windshield wiper arms into the service position before lifting.
2. Lift the wiper arms, making sure to only hold the wiper arms in the area where they attach to the wiper blade.
3. Press and hold the release button and remove the wiper blade at the same time in the direction of the arrow *fig. 152* ⓘ.
4. Insert a new wiper blade of the same length and type on the respective wiper arm until it engages.
5. Place the wiper arms carefully on the windshield.

⚠ WARNING

Worn or dirty wiper blades reduce visibility and increase the risk of accidents and serious injuries.

- Always replace wiper blades if they are damaged or worn and are no longer cleaning the windshield sufficiently.

ⓘ NOTICE

Damaged or dirty wiper blades can scratch the window glass.

- Do not use any cleaning materials containing solvents, hard sponges, and other sharp-edged objects because they can damage the graphite coating on the wiper blades.
- Do not clean the windshield and windows with fuel, nail polish remover, paint thinner, or other similar fluids.

🔧 If there is wax residue on the windshield and rear window from car wash systems and other products, this can cause the windshield wipers to rub. Remove any wax residue with a special cleaner or cleaning towels.

Exterior lighting

📖 Exterior lighting using LED technology

The exterior lighting may use LEDs technology. It is not possible to change LEDs by yourself. The malfunction of individual LEDs may be an indication that more or less malfunction. If this is the case, have lights checked and, if necessary, replaced by an authorized Volkswagen dealer or authorized Volkswagen Service Facility. Volkswagen recommends contacting an authorized Volkswagen dealer or authorized Volkswagen Service Facility.

Driving with exterior lighting that is inoperative may be against the law.

⚠ WARNING

Accidents can occur if the road is not well lit and the vehicle cannot be seen by others on the road, or is very difficult to see by others.

Replacing fuses

Introduction

Due to the constant development of the vehicle, equipment-dependent fuse allocations, and the combined protection of multiple electrical equipment items using one fuse, a complete overview of the fuse layout is not available at the time of print. Detailed information about fuse allocations can be obtained from suitably qualified professionals. Volkswagen recommends contacting an authorized Volkswagen dealer or authorized Volkswagen Service Facility.

Generally, multiple electrical equipment items can be protected together through by fuse. On the other hand, some equipment items may use multiple fuses.

Only replace fuses if the cause for the malfunction has been fixed. If a new fuse blows again after a short time, the electrical system must be checked by suitably qualified professionals. Volkswagen recommends contacting an authorized Volkswagen dealer or authorized Volkswagen Service Facility.

WARNING

High voltage in the electrical system can cause electric shocks, serious burns, and fatal injuries.

- Never touch the electrical wires in the ignition system.
- Avoid short circuits in the electrical system.

WARNING

Using unsuitable fuses, repairing fuses, and bridging a power circuit without fuses can causes fires and serious injuries.

- Never install fuses that have a higher amp rating.
- Replace fuses only with fuses of same rating and size. Make sure that the color and label are identical to the faulty fuse.
- Never repair fuses.
- Never use metal strips, paper clips or similar objects as substitutes for fuses.

NOTICE

To prevent the risk of damaging the electrical system in the vehicle, the ignition, the lights, and all electrical equipment must be switched off before a fuse can be replaced.

- Make sure that the ignition cannot be switched on while a fuse is being replaced.

NOTICE

If a fuse is replaced by another fuse with a higher amp rating, this could also damage the electrical system in another location.

NOTICE

Dirt and moisture in the fuse boxes can damage the electrical system.

- Protect open fuse boxes from dirt and moisture.

NOTICE

To reduce the risk of vehicle damage, observe the following:

- Carefully remove and correctly re-mount the covers of the fuse boxes.

 There are more fuses in the vehicle than are specified in this chapter. These should only be replaced by an authorized Volkswagen dealer or authorized Volkswagen Service Facility qualified in this respect. Volkswagen recommends contacting an authorized Volkswagen dealer or authorized Volkswagen Service Facility.

Fuses in the engine compartment

 Please read the introductory information and heed the Warnings and Notice  and  Introduction.

Opening the fuse box in the engine/motor compartment

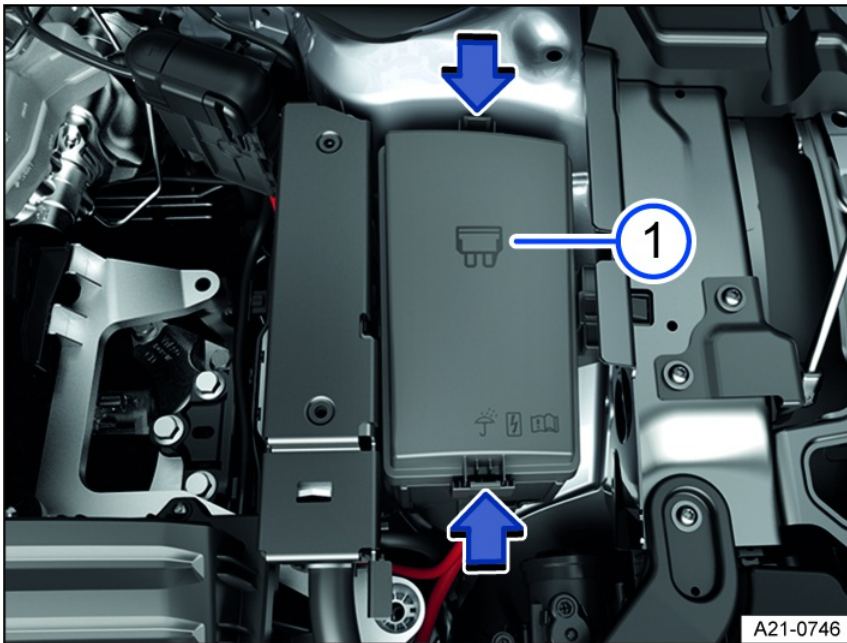

Fig. 153 In the engine compartment: Fuse box.

① Fuse box cover.

The plastic pliers *fig. 153* for removing fuses can be found on the inside of the fuse box cover or on the fuse panel.

Removing the cover

1. Open the hood.
2. Press the catches in the direction of the arrow to unlock the fuse box cover *fig. 153* ①.
3. Remove the cover upward.

Fitting the cover

1. Place the cover onto the fuse box.
2. Push the cover downwards until it audibly clicks into place on both sides.

Fuse table for fuses in the engine compartment

📖 Please read the introductory information and heed the Warnings and Notice ⇒ ⚠ and ⚠ Introduction.

The list shows the fuse locations for the equipment relevant to the driver. The first column of the table contains the fuse location; the other columns include the rate current, fuse version, and the protected electrical equipment.

Depending on the market and the vehicle equipment, there may be differences from the fuse numbers and fuse slots listed in the table. If necessary, ask for the exact fuse assignment from suitably qualified professionals. Volkswagen recommends contacting an authorized Volkswagen dealer or authorized Volkswagen Service Facility.

Fuse assignment

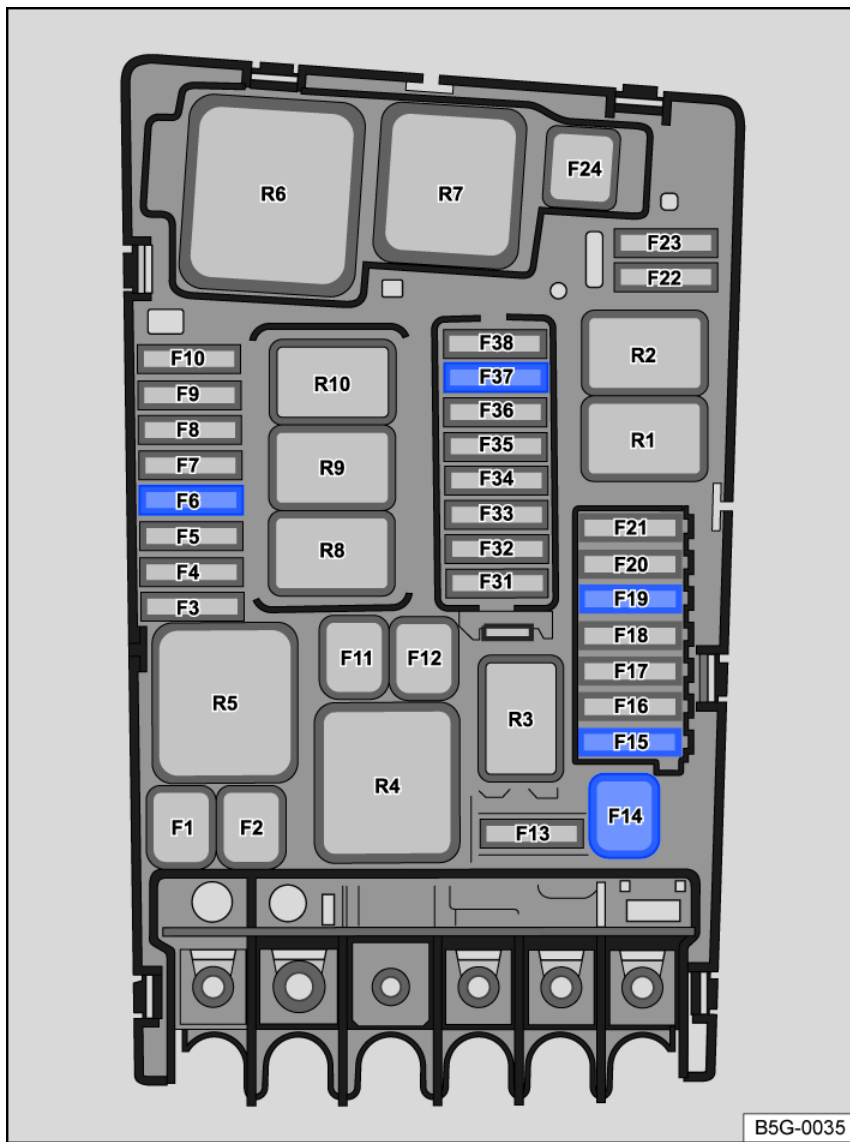

Fig. 154 Fuse locations in the engine compartment.

Fuse location *fig. 154*:

- F6** 7.5 Amp, ATO®, brake light sensor.
- F15** 15 A, ATO®, horn.
- F19** 30 Amp, ATO®, windshield wipers.

Fuses in the instrument panel

📖 Please read the introductory information and heed the Warnings and Notice ⇒ ⚠️ and ⚠️ Introduction.

Left-hand drive vehicles: Opening the fuse box in the instrument panel

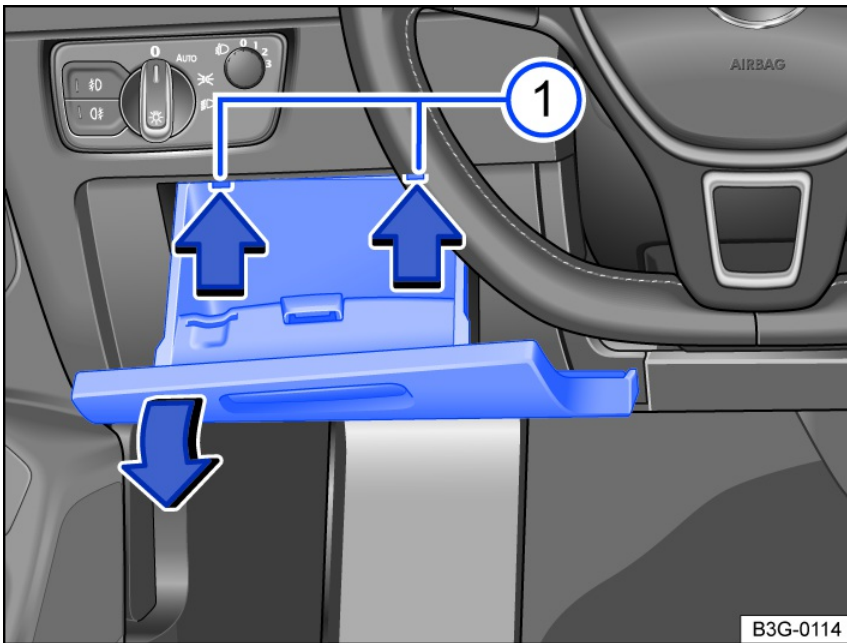

Fig. 155 Left-hand drive vehicles, to the left of the steering wheel: Fuse box cover in the left-hand drive vehicle instrument panel.

① Retaining tabs.

Removing the cover

1. Open and, if necessary, empty the storage compartment *fig. 155*.
2. Press the retaining tabs upward in the direction of the arrow and, at the same time, open the storage compartment further and remove it until the fuse panel is accessible *fig. 155* ①.

Fitting the cover

1. Press the storage compartment into the mounts in the instrument panel until you hear the catch engage on both sides, and close the compartment.

Right-hand drive vehicles: opening the fuse box in the instrument panel

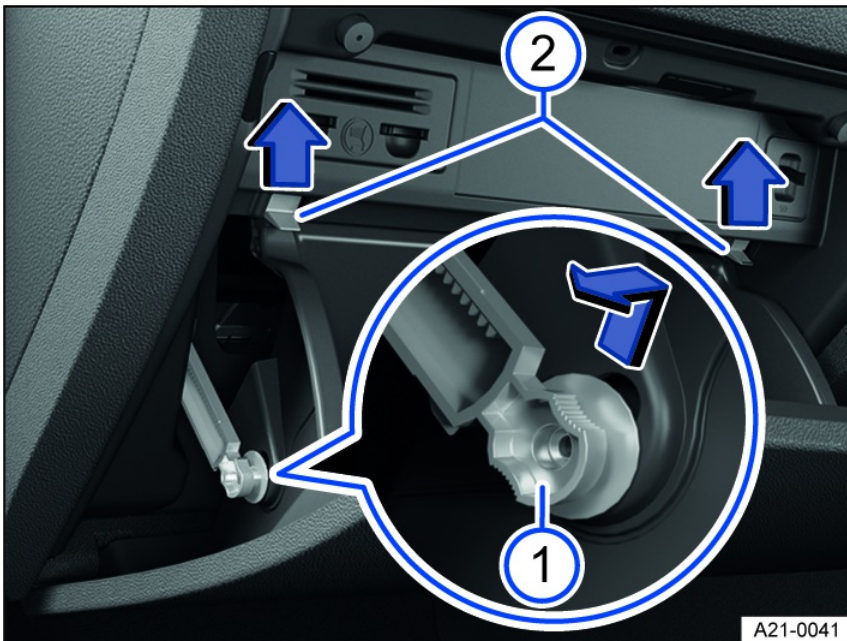

Fig. 156 Right-hand drive vehicles, on the passenger's side: Fuse box cover in the instrument panel.

① Damper element.

② Stop pin.

Removing the cover

1. Open the glove box, and empty it if necessary *fig. 156*.
2. Push the damper element up and into the opening in the bracket, before pulling it out sideways *fig. 156* ①.
3. Press the stop pin upward in the direction of the arrow *fig. 156* ②.

Fitting the cover

1. Move the storage compartment into position. Fit the damper element into the opening in the bracket and push it down until you hear it click into place. Push the

storage compartment carefully forwards past the resistance of the stop pin *fig. 156* ②.

Fuse table for fuses in the instrument panel

📖 Please read the introductory information and heed the Warnings and Notice ⇒ ⚠ and ⓘ Introduction.

The list shows the fuse locations for the equipment relevant to the driver. The first column of the table contains the fuse location; the other columns include the rate current, fuse version, and the protected electrical equipment.

Depending on the market and the vehicle equipment, there may be differences from the fuse numbers and fuse slots listed in the table. If necessary, ask for the exact fuse assignment from suitably qualified professionals. Volkswagen recommends contacting an authorized Volkswagen dealer or authorized Volkswagen Service Facility.

Fuse assignment

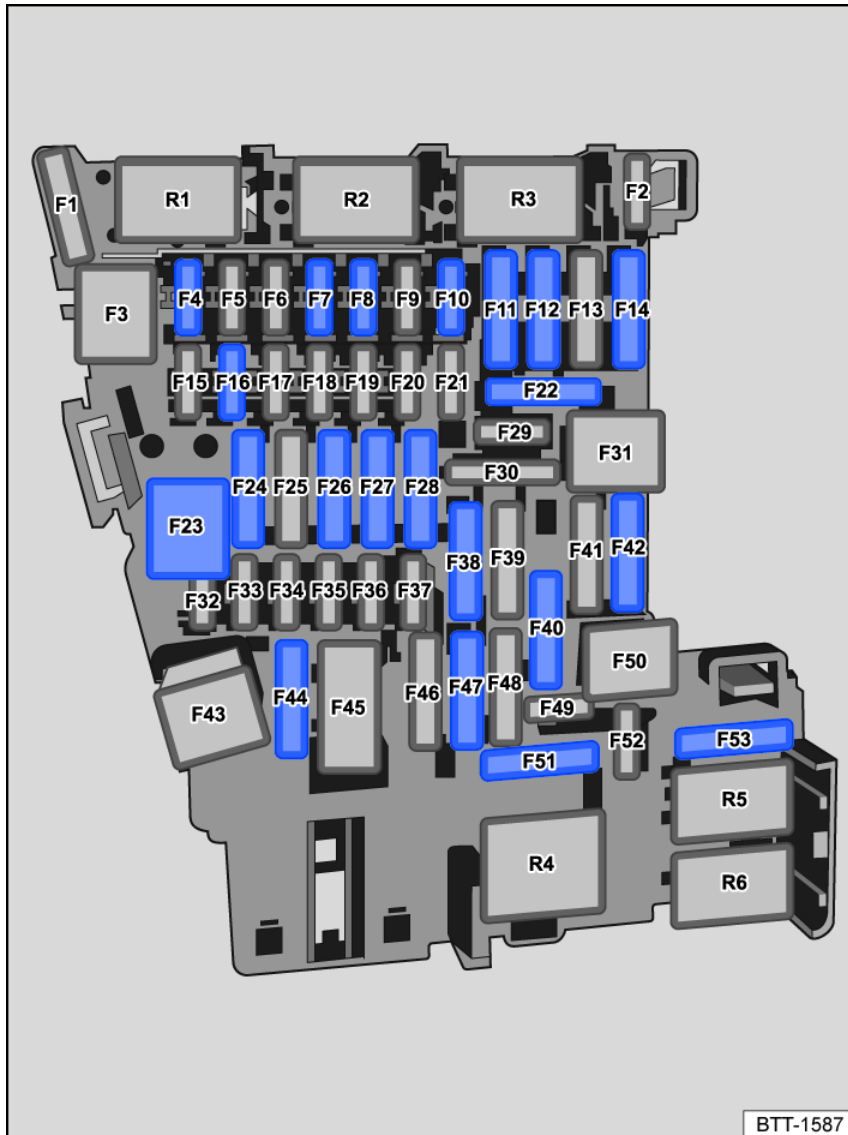

Fig. 157 Fuse assignment in the instrument panel.

Fuse locations *fig. 157*:

- | | |
|------------|--|
| F4 | 7.5 Amp, MINI® , anti-theft alarm system. |
| F6 | 10 A, ATO® , automatic transmission selector mechanism. |
| F7 | 10 amp, MINI® , control for the air conditioner, rear window defroster relay. |
| F8 | 7.5 Amp, MINI® , dipped beam light switch, rain/light sensor, electronic parking brake. |
| F10 | 7.5 Amp, MINI® , Display, Infotainment system control panel. |
| F11 | 40 Amp, ATO® , exterior lighting on the left side. |
| F12 | 20 Amp, ATO® , Infotainment system. |
| F14 | 40 Amp, ATO® , blower regulator. |
| F16 | 7.5 Amp, MINI® , telephone. |
| F23 | 20 Amp, JCASE® , power sunroof. |



- F24 40 Amp, ATO®, exterior lighting on the right side.
- F26 30 Amp, ATO®, seat heating.
- F27 30 Amp, ATO®, interior lighting.
- F40 20 Amp, ATO®, cigarette lighter, sockets. Note the installation position, factory-standard fuse location as shown in the illustration.
- F42 40 Amp, ATO®, central locking system.
- F51 25 Amp, ATO®, rear seat heating.
- F53 30 Amp, ATO®, rear window defroster.

Fuse locations for vehicles with a factory-installed trailer hitch.

- F22 15 amp, ATO®, trailer charging cable.
- F28 25 Amp, ATO®, left trailer control module.
- F38 25 Amp, ATO®, right trailer control module.
- F44 15 Amp, ATO®, trailer control module.

 Power windows and seats can be protected by circuit breakers or control modules, which switch back on automatically several seconds after correcting the overload, for example when door windows are frozen shut.

Replacing blown fuses

 Please read the introductory information and heed the Warnings and Notice  and  Introduction.

Preparations

1. Switch off the ignition, lights, and all other electrical equipment.

Detecting blown fuses

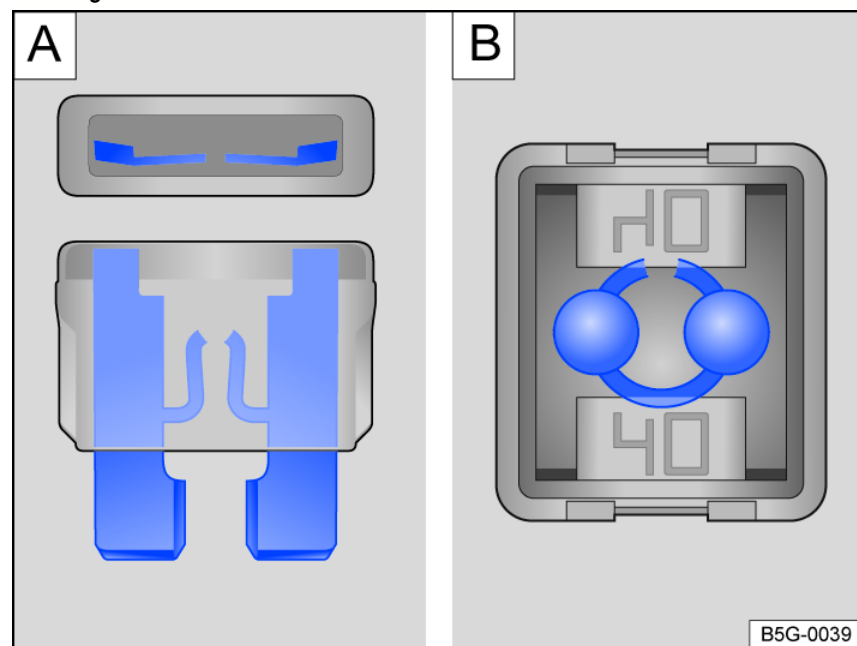

Fig. 158 Blown fuse (general example).

- A blown flat connector fuse (ATO®, MINI®) has metal strips that have burned through, which you can see through the transparent housing from above and from the side [fig. 158 A](#).
- A blown block fuse (JCASE®) is recognizable by the melted metal strip seen through the transparent housing from above [fig. 158 B](#).

Fuse versions

- Standard flat connector fuse (ATO®).
- Small flat connector fuse (MINI®).
- Block fuse (JCASE®).

Fuse color codes

Fuses (ATO® - MINI®).

Color Current rating

Black 1 A

Purple 3 A
Orange 5 A
Brown 7.5 A
Red 10 A
Blue 15 A
Yellow 20 A
White or clear 25 A

Green 30 A
Light green 40 A

Fuses (JCASE®)

Blue 20 A
Pink 30 A
Green 40 A
Red 50 A
Yellow 60 A

Replacing fuses

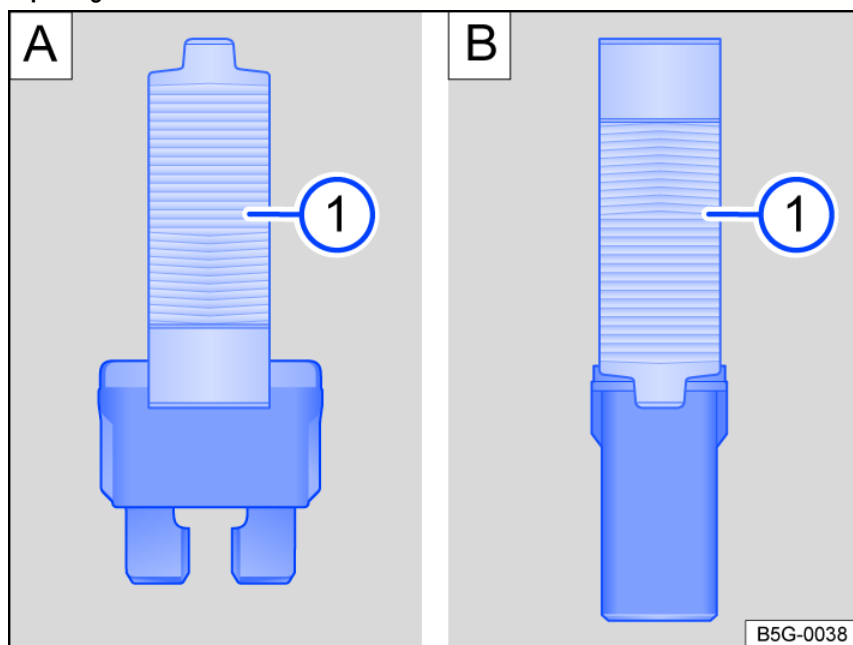

Fig. 159 Remove or install a fuse with the plastic pliers (general example).

① Plastic pliers.

1. Remove plastic tongs from either the fuse box or the cover of the fuse box *fig. 159* ①.
2. Depending on the design of the fuse, slide the appropriately sized clamp on the plastic pliers onto the fuse from above or from the side *fig. 159*.
3. Remove the fuse.
4. If a fuse is blown, replace with a fuse with the same rating (same color and same label) and the same size ⇒ ①.
5. After inserting the new fuse, place the plastic pliers back in the cover, if necessary.
6. Reinstall the cover or close the fuse box cover.

⚠ NOTICE

If a fuse is replaced by a fuse with a higher current rating, this could damage the electrical system in another location.

Jump-starting

📖 Introduction

For technical reasons the vehicle must not be tow-started ⇒ ①. If the engine cannot start because the 12 V vehicle battery is dead, the 12 V vehicle battery on

another vehicle can be used to start your vehicle.

For vehicles with a 12 V vehicle battery in the vehicle interior or luggage compartment, the jumper cables may only be connected to the jump-start points in the engine compartment.

⚠ WARNING

Using jumper cables and performing a jump-start incorrectly can cause the 12 V vehicle battery to explode, which can cause serious injuries.

- Always read and heed the warnings and safety precautions before working on the 12 V vehicle battery ⇒ *Introduction*.
- Never confuse the positive battery terminal with the negative battery terminal.
- Never jump-start a vehicle with a frozen or thawed 12 V vehicle battery.

⚠ WARNING

When jump-starting the 12 V vehicle battery, a highly explosive mixture of gas builds up, which is flammable and can cause serious injuries. Sparks could form and ignite the flammable gas that is released by the 12 V vehicle battery.

- Always keep fires, sparks, open flames, and lit cigarettes far away from the 12 V vehicle battery.
- Avoid discharging static electricity near the 12 V vehicle battery.

ⓘ NOTICE

Tow-starting can cause damage to the vehicle.

- Jump-start the vehicle to start the engine.

ⓘ NOTICE

A drained 12 V vehicle battery can freeze at temperatures around +32°F (0 °C).

- Always replace a frozen or thawed 12 V vehicle battery.

Ground jump-start point

Please read the introductory information and heed the Warnings and Notice ⇒ and *Introduction*.

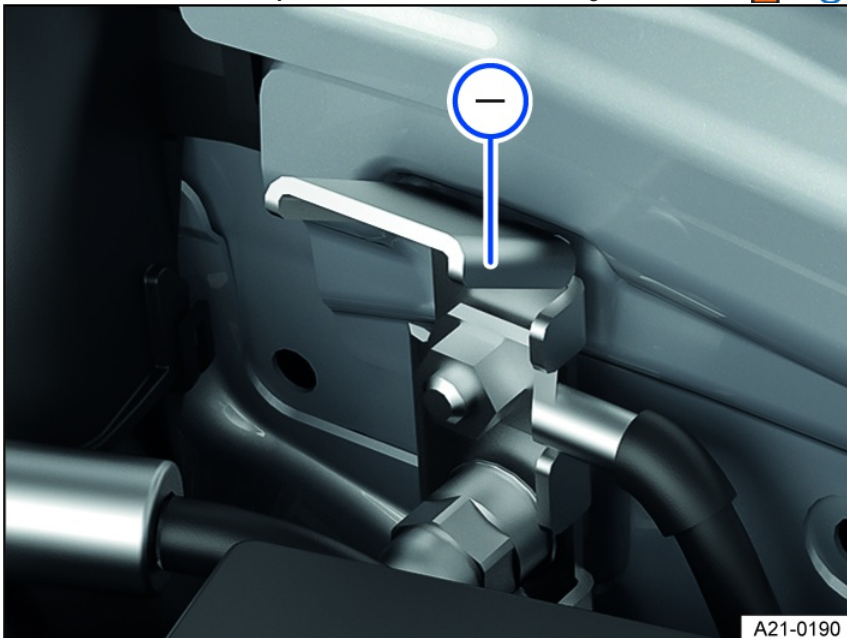

Fig. 160 In the engine compartment: Negative terminal jump-start point.

□ The jump-start point (negative terminal) is for connecting the black jumper cable *fig. 160*.

The vehicle can give and receive a jump-start using this negative terminal jump-start point.

Positive jump-start point

Please read the introductory information and heed the Warnings and Notice ⇒ and *Introduction*.

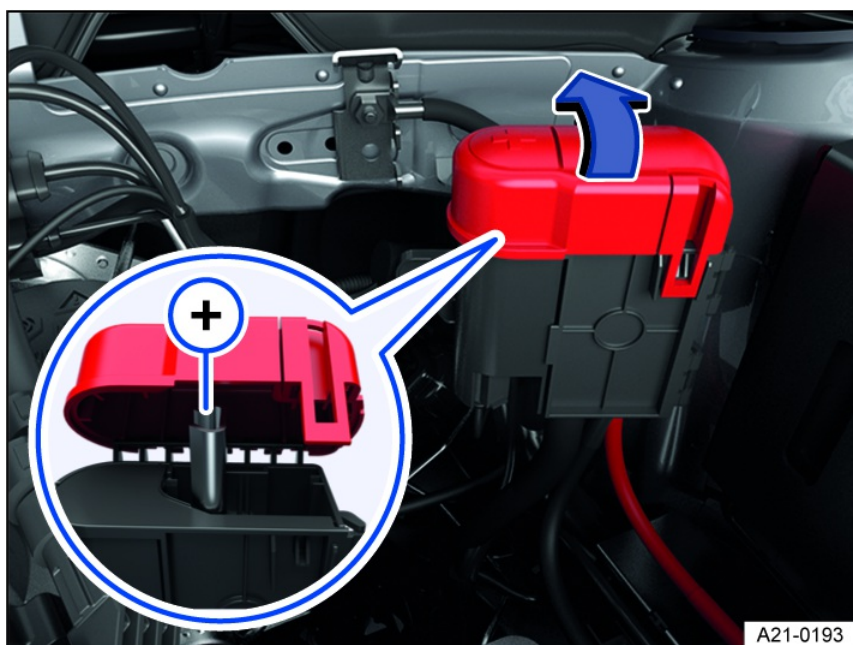

Fig. 161 Under a cover in the engine compartment: Positive jump-start point.

- ⊕ In vehicles with a 12 V vehicle battery in the luggage compartment, the jump-start point (positive battery terminal) for connecting the red jumper cable is located under a cover in the engine compartment.

The vehicle can give and receive a jump-start using this positive terminal jump-start point.

Preparing and Performing a Jump-start

📖 Please read the introductory information and heed the Warnings and Notice ⇒ ⚠ and ⚠ Introduction.

Preparations

Observe the following for jump-starting:

- Wear suitable eye protection and safety gloves ⇒ ⚠.
- Pay attention to the operating instructions provided by the manufacturer of the jump-start cables.
- Open the hood.
- Always use a jumper cable with fully insulated terminal clamps and without any insulation defects for jump-starting ⇒ ⚠.
- Ensure that there is sufficient distance between the vehicle providing the jump-start and the vehicle receiving the jump-start, otherwise current could already flow when connecting the positive battery terminals.
- Make sure the terminal clamps have sufficient contact with metal.

Jumper cable

So that vehicles can be jump-started and can jump-start others, an appropriate jumper cable is required.

The following jumper cable wire diameters must not be fallen short of by the vehicle providing the jump-start.

- Vehicles with electric drivetrain: To jump-start the vehicle with a drained 12 V vehicle battery, the wire diameter of the jumper cable must be at least 25 mm² (0.038 in²).
- Vehicles with hybrid drive: To jump-start the vehicle with a drained 12 V vehicle battery, the wire diameter of the jumper cable must be at least 25 mm² (0.038 in²).
- Vehicles with a gasoline engine: To jump-start the vehicle with a drained 12 V vehicle battery, the wire diameter of the jumper cable must be at least 25 mm² (0.038 in²).
- Vehicles with a diesel engine: To jump-start the vehicle with a drained 12 V vehicle battery, the wire diameter of the jumper cable must be at least 35 mm² (0.054 in²).

Vehicle Receiving the Jump-start

1. Check whether the discharged 12 V vehicle battery is properly connected to the 12 V vehicle electrical system.
2. If a 12 V vehicle battery with a viewing window has been installed, check the color of the viewing window. If the viewing window is light yellow or has no color, do not perform a jump-start and contact an authorized Volkswagen dealer or authorized Volkswagen Service Facility.

Vehicle Providing the Jump-start

1. Pay attention to the operating instructions provided by the vehicle manufacturer.
2. Check whether the battery providing the jump-start has the same voltage (12 V) and approximately the same battery capacity as the dead 12 V vehicle battery. Pay attention to the information printed on the battery of the vehicle providing the jump-start.

Jump-Starting for Vehicles with a 12 V Vehicle Battery in the Engine Compartment

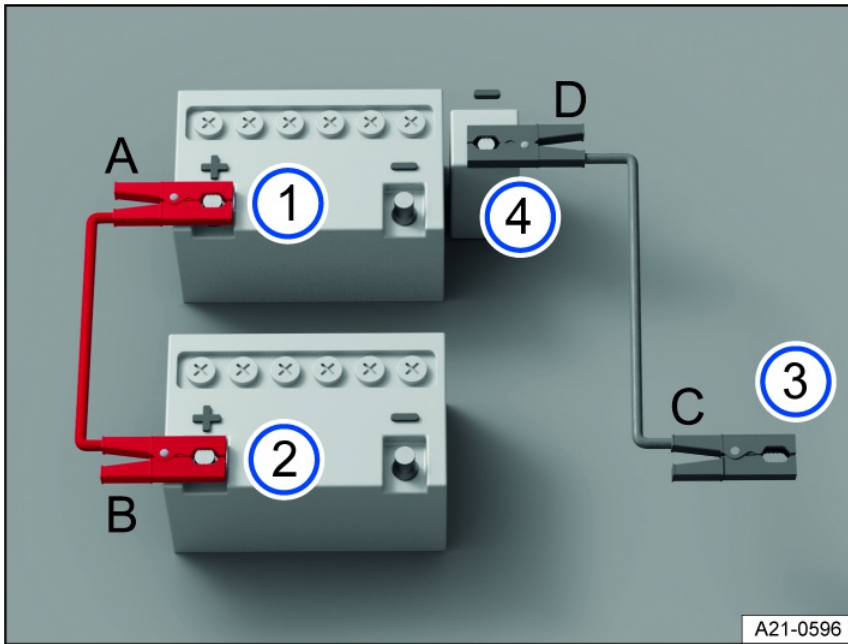



Fig. 162 Diagram for connecting jumper cables in vehicles with a 12 V vehicle battery in the engine compartment.

- ① Positive battery terminal of the vehicle receiving the jump-start.
- ② Positive battery terminal of the vehicle providing the jump-start.
- ③ Suitable negative terminal of the vehicle providing the jump-start: Preferably a jump-start point (negative connection), a large metal part that is bolted securely to the engine block, or the engine block itself.
- ④ Negative jump-start point of the vehicle receiving the jump-start.

Only connect the jumper cables in the sequence A – B – C – D *fig. 162*.

1. Switch the ignition off on both vehicles.
2. In the engine compartment, open the cover on the positive battery terminal (+) of the 12 V vehicle battery, if fitted.
3. Connect one end of the red jumper cable to the positive battery terminal (+) of the 12 V vehicle battery with the discharged 12 V vehicle battery *fig. 162* ① = .
4. Connect the other end of the red jumper cable to the positive battery terminal (+) on the vehicle providing current *fig. 162* ②.
5. Connect one end of the black jumper cable preferably to the negative terminal (–) jump-start point on the vehicle with the 12 V vehicle battery providing current *fig. 162* ③.
Or: If there is no negative terminal (–) jump-start point, connect the end of the black jumper cable to a large metal part that is bolted securely to the engine block, or the engine block itself, on the vehicle with the 12 V vehicle battery providing current *fig. 162* ③.
6. Connect the other end of the black jumper cable to the negative terminal (–) jump-start point on the vehicle with the discharged 12 V vehicle battery *fig. 162* ⇒ .
7. Route the jumper cables so that they cannot become caught in moving parts in the engine compartment.

Jump-Starting for Vehicles with a 12 V Vehicle Battery in the Vehicle Interior

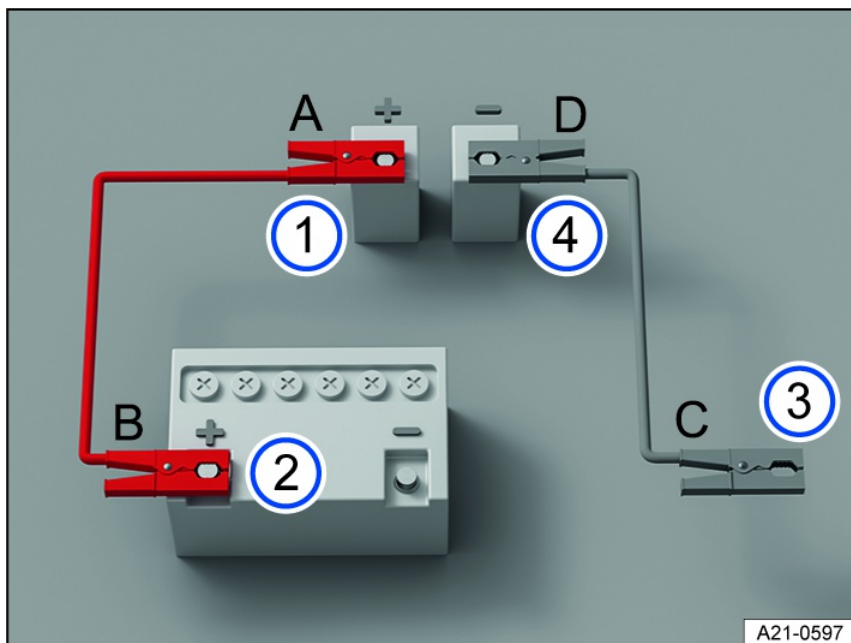

Fig. 163 Diagram for connecting jumper cables for vehicles with a 12 V vehicle battery in the vehicle interior.

- ① Positive jump-start point of the vehicle receiving the jump-start.
- ② Positive battery terminal of the vehicle providing the jump-start.
- ③ Suitable negative terminal of the vehicle providing the jump-start. Preferably a jump-start point (negative), otherwise a large metal part that is bolted securely to the engine block, or the engine block itself.
- ④ Negative jump-start point of the vehicle receiving the jump-start.

Only connect the jumper cables in the sequence A – B – C – D *fig. 163*.

1. Switch the ignition off on both vehicles.
 2. In the engine compartment, open the cover on the positive jump-start point (+), if fitted.
 3. Connect one end of the red jumper cable to the positive jump-start point (+) of the vehicle with the discharged 12 V vehicle battery *fig. 163* ① ⇒ ⚠.
 4. Connect the other end of the red jumper cable to the positive battery terminal (+) on the vehicle providing current *fig. 163* ②.
 5. Connect one end of the black jumper cable preferably to the negative terminal (–) jump-start point on the vehicle with the 12 V vehicle battery providing current *fig. 163* ③.
- Or:** If there is no negative terminal (–) jump-start point, connect the end of the black jumper cable to a large metal part that is bolted securely to the engine block, or the engine block itself, on the vehicle with the 12 V vehicle battery providing current *fig. 163* ③.
6. Connect the other end of the black jumper cable to the negative terminal (–) jump-start point on the vehicle with the discharged 12 V vehicle battery *fig. 163* ⇒ ⚠.
 7. Route the jumper cables so that they cannot become caught in moving parts in the engine compartment.

Start the engine

1. Start the engine in the vehicle that is providing current and allow it to idle.
2. Wait a few minutes and then start the vehicle's engine with the discharged 12 V vehicle battery. If the engine does not start, stop the starting process after ten seconds, and try again after approximately one minute.

If the engine still will not start, contact an authorized Volkswagen dealer or authorized Volkswagen Service Facility.

Removing the jumper cables

1. Before disconnecting the jumper cables, switch off the low beam headlight if necessary.
2. In the vehicle with the drained 12 V vehicle battery, switch on the blower for the air conditioner and the rear window defroster. This will reduce any voltage surges that may occur when disconnected.
3. Once the vehicle has been jump-started, always disconnect the jumper cables in the order D – C – B – A *fig. 162* or *fig. 163*.
4. Close the cover of the positive jump-start point (+) or the positive terminal of the 12 V vehicle battery, if fitted.

After successful jump-starting, have the 12 V vehicle battery checked by an authorized Volkswagen dealer or authorized Volkswagen Service Facility. Volkswagen recommends contacting an authorized Volkswagen dealer or authorized Volkswagen Service Facility.

⚠ WARNING

Performing a jump-start incorrectly can cause the 12 V vehicle battery to explode, which can cause serious injuries.

- Always wear suitable protective eyewear and protective gloves, and never bend over the 12 V vehicle battery.
- Always connect the positive cable first and then the negative cable.
- Never connect the negative terminal to parts of the fuel system or to the brake lines.
- Ensure that there is no contact between the non-insulated parts of the terminal clamps.
- Make sure the cable insulation is free from any defects.
- Make sure that the cable that is connected to the positive battery terminal on the 12 V vehicle battery does not come into contact with any vehicle components that conduct electricity.

ⓘ NOTICE

A drained 12 V vehicle battery can freeze at temperatures around +32°F (0 °C).

- Do not jump-start a frozen or thawed 12 V vehicle battery.

Towing

📖 Introduction

Towing requires practice, particularly if a towing cable is used. Both drivers should be familiar with the special considerations when towing. Inexperienced drivers should not tow.

Follow all applicable laws when towing.

Always make sure the towing force does not exceed the permitted level and there are no shock loading conditions. There is always the risk of the coupling becoming overloaded when driving off-road.

⚠ WARNING

The vehicle handling and braking efficiency will change considerably when it is towed.

⚠ WARNING

Never tow a vehicle that has no electrical power.

- Never turn off the ignition with the starter button while towing. Otherwise, the electronic steering column lock could engage suddenly. The vehicle cannot be steered if this happens. This can result in crashes, serious injuries, and a loss of control of the vehicle.
- If the vehicle loses power while it is being towed, stop towing the vehicle immediately and see an authorized Volkswagen dealer or authorized Volkswagen Service Facility for assistance.

ⓘ NOTICE

When pushing the vehicle by hand, the taillights, side spoiler on the rear window, and large sections of sheet metal could be damaged and the rear spoiler could detach.

- When pushing the vehicle by hand, do not press on the taillights, side spoiler on the rear window, large sections of sheet metal, or the rear spoiler.

Towing

Towing refers to using a vehicle to pull another vehicle that cannot be driven.

The vehicle can be towed using a tow bar or tow rope:

- The maximum permissible speed is 30 mph (50 km/h).
- The maximum permissible distance is 30 miles (50 km).

The easiest and safest way to tow is using a tow bar. You should use a towing cable only if a tow bar is not available. The towing cable should be elastic to protect both vehicles. Use a cable made of synthetic rubber or a similar elastic material.

Towing with a tow truck

If your vehicle will be raised by one axle when towing, only the axle listed below may be raised, depending on the transmission and engine combination:

Front-wheel drive

Automatic transmission Front axle

Manual transmission Front axle

All-wheel drive (4MOTION)

Automatic transmission Front axle



Manual transmission Front axle

WARNING

Vehicle components can be badly damaged by incorrectly attached tow ropes or tow bars. This increases the risk of accident and could result in serious injuries.

- Only ever secure the vehicle to be recovered and towed at the points designed for this purpose.
- Never secure the tow rope or the tow bar to axle or suspension components.
- Contact an authorized Volkswagen dealer or authorized Volkswagen Service Facility and have the vehicle taken away on a tow truck, if necessary.

Instructions for towing

 Please read the introductory information and heed the Warnings and Notice ⇒  and  Introduction.

A vehicle being towed can still signal a turn using the turn signals even if the emergency flashers are switched on. To do this when the ignition is switched on, activate the turn signal for the desired direction. The emergency flashers will stop while the turn signal is active. The emergency flashers will automatically activate again once the turn signal and high beam lever returns to the neutral position.

When may this vehicle not be towed?

The vehicle must not be towed in the following situations:

- If the 12 V vehicle battery is drained.
- The indicator in the instrument cluster display does not function perfectly.
- If the towing distance is greater than 30 miles (50 km).
- The selector lever of the automatic transmission cannot be moved to neutral (position N).
- The electronic parking brake cannot be released.
- The steering column lock cannot be released.
- If the wheel clearance or the steering function can no longer be secured after an accident.

If the vehicle cannot be towed on its own wheels due to one of the conditions listed, contact professional assistance and have the vehicle transported by a tow truck if necessary.

Towing

 Please read the introductory information and heed the Warnings and Notice ⇒  and  Introduction.

Secure the tow rope or tow bar only at the permitted points:

- Towing lug.
- Ball mount.

WARNING

Never secure the tow rope or the tow bar to axle or suspension components. They can be damaged and cause accidents and serious injuries.

- Contact an authorized Volkswagen dealer or authorized Volkswagen Service Facility and have the vehicle taken away on a tow truck, if necessary.

Preparations

- Make sure the tow rope is not twisted. Otherwise it could disconnect from the towing eye while towing.
- Switch the ignition and emergency flashers on in both vehicles. However, do not do this if it is prohibited by law.
- Read and comply with the information and instructions for towing given in the Owner's Manual for the other vehicle.

Towing vehicle (front)

1. Only start to drive when the tow rope is taut.
2. Be especially careful when accelerating.
3. Avoid sudden braking and driving maneuvers.
4. Do not exceed the permitted towing weight of the vehicle.

Vehicle being towed (rear)

1. Make sure the ignition is always switched on so that the steering wheel is not locked and so that the turn signal and windshield wiper can be used if needed.
The brake booster and power steering only work when the engine is running. Otherwise, the brake pedal needs to be pressed much harder and more force is required to steer.
2. Make sure the vehicle key is always in the vehicle during the towing process ⇒  Introduction.

3. For vehicles with an automatic gearbox: Select the selector lever position **N**.
4. Release the electronic parking brake.
5. Make sure the tow rope is always taut.

NOTICE

The vehicle can only be towed if the battery charge level of the 12 V vehicle battery is sufficient and the electronic parking brake and steering column lock can be released. If there is a loss of power or the electrical system is malfunctioning, the engine may need to be jump-started or the vehicle's drive system may need to be reactivated in order to release the electronic parking brake and steering column lock.

Installing the front towing eye

📖 Please read the introductory information and heed the Warnings and Notice ⇒ ⚠ and ⓘ Introduction.

Depending on the country and vehicle equipment, the mount for the towing eye is situated behind the bumper cover.

1. Before having it towed, check that your vehicle has a threaded mount for the towing lug.
2. Read and heed the information about towing.
3. Otherwise, contact an authorized Volkswagen dealer or authorized Volkswagen Service Facility and have the vehicle taken away by a tow truck if necessary.

The towing eye must always be kept in the vehicle ⇒ ⓘ.

NOTICE

Using a towing eye that is not suitable for the vehicle can damage the vehicle.

- When towing, always use the towing eye enclosed with your own vehicle in the vehicle tool kit, or another towing eye suitable for the vehicle.

Installing the front towing eye



Fig. 164 In the right front bumper: Remove cover.



Fig. 165 In the right front bumper: Screw in towing eye.

1. Remove the towing eye and extraction hook from the vehicle tool kit in the luggage compartment.
2. Insert the extraction hook into the cutout of the cover from below and pull the cover out of the catches in the direction of the arrow *fig. 164*.
3. Remove the cover toward the front and place in the vehicle ⇒ ⓘ.
4. Rotate the towing eye in the direction of the arrow as far as possible to install it in the mount *fig. 165*, ⇒ ⓘ. Use a suitable object to tighten the towing eye completely and securely in the mount.
5. After the vehicle has been towed, unscrew the towing eye with a suitable object in the opposite direction to the arrow.
6. Take the cover out of the vehicle and insert the upper lugs of the cover into the opening in the bumper. Press on the lower part of the cover until the lower lug latches into the bumper.
7. If necessary, clean the towing eye and return it to the vehicle tool kit in the luggage compartment.

ⓘ NOTICE

Removing and installing the towing eye and the cover can cause vehicle damage, such as paint damage.

- Remove and install the towing eye and cover carefully to reduce the risk of vehicle damage.

ⓘ NOTICE

If the towing eye is not fully and tightly screwed into the mount, it may tear out of the mount when tow-starting or towing the vehicle.

- Always screw the towing eye completely and securely into the mount.

Installing the rear towing eye

📖 Please read the introductory information and heed the Warnings and Notice ⇒ ⚠️ and ⓘ Introduction.

Depending on the country and vehicle equipment, the mount for the towing eye is situated behind the bumper cover.

1. Before having it towed, check that your vehicle has a threaded mount for the towing lug.
2. Read and heed the information about towing.
3. Otherwise, contact an authorized Volkswagen dealer or authorized Volkswagen Service Facility and have the vehicle taken away by a tow truck if necessary.

The towing eye must always be kept in the vehicle ⇒ ⓘ.

ⓘ NOTICE

Using a towing eye that is not suitable for the vehicle can damage the vehicle.

- When towing, always use the towing eye enclosed with your own vehicle in the vehicle tool kit, or another towing eye suitable for the vehicle.

Installing the rear towing eye



Fig. 166 In the right rear bumper: Remove cover.

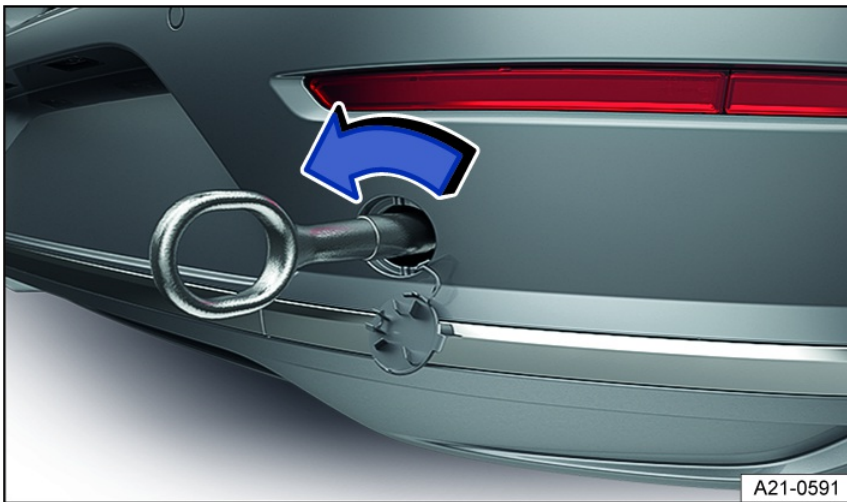

Fig. 167 In the right rear bumper: Screw in towing eye.

1. Remove the towing eye from the vehicle tool kit in the luggage compartment.
2. Press on the marked area of the cover in the direction of the arrow to release the catch on the cover *fig. 166*.
3. Remove the cover, let it hang from the vehicle or place it in the vehicle if necessary ⇒ ⚠.
4. Rotate the towing eye in the direction of the arrow as far as possible to install it in the mount *fig. 167*, ⇒ ⚠. Use a suitable object to tighten the towing eye completely and securely in the mount.
5. After the vehicle has been towed, unscrew the towing eye with a suitable object in the opposite direction to the arrow.
6. Insert the cap into the respective opening and press in until it engages.
7. If necessary, clean the towing eye and return it to the vehicle tool kit in the luggage compartment.

⚠ NOTICE

Removing and installing the towing eye and the cover can cause vehicle damage, such as paint damage.

- Remove and install the towing eye and cover carefully to reduce the risk of vehicle damage.

⚠ NOTICE

If the towing eye is not fully and tightly screwed into the mount, it may tear out of the mount when tow-starting or towing the vehicle.

- Always screw the towing eye completely and securely into the mount.

Vehicles with a trailer hitch

In vehicles with a factory-equipped trailer hitch, there is no mount for the threaded towing eye behind the cover.

1. To tow, swivel the ball hitch out or mount and use it.

⚠ NOTICE

Using an unsuitable towing bar could damage the ball hitch and the vehicle. Vehicles with a factory-installed trailer hitch may only tow other vehicles with a

towing bar that is designed specially for mounting on a ball mount.

- Use a suitable tow bar to tow the vehicle.
- If you do not have a suitable tow bar, use a tow rope for towing.

Checking and filling

In the engine compartment

Safety precautions for working in the engine compartment

The engine compartment is a potentially dangerous area in the vehicle. Only perform work in the engine compartment if you are familiar with the necessary activities and the general safety precautions, and if the correct operating equipment, fluids and suitable tools are available. Work performed incorrectly can result in serious injuries ⇒ . Have all work performed by suitably qualified professionals if necessary. Volkswagen recommends contacting an authorized Volkswagen dealer or authorized Volkswagen Service Facility.

WARNING

The engine compartment in any motor vehicle is a potentially dangerous area that can cause serious personal injury.

- Always work as cautiously and carefully as possible and follow the general safety instructions when working on the vehicle.
- Never perform work in the engine compartment if you are not familiar with the required activities. If you are not sure what to do, have the work performed by an authorized Volkswagen dealer or authorized Volkswagen Service Facility qualified in this respect. Serious injuries can result if work is not performed correctly. Volkswagen recommends contacting an authorized Volkswagen dealer or authorized Volkswagen Service Facility.
- Never open or close the hood if steam or engine coolant is escaping. Steam or hot engine coolant can cause serious burns. Always wait until you can no longer see or hear steam or engine coolant escaping from the engine compartment.
- Always allow the engine to cool down before opening the hood.
- Hot engine or exhaust system components can cause burns if touched.
- Before opening the hood, take note of the following:
 - Activate the electronic parking brake and move the selector lever into the **P** position or move the gearshift lever into the neutral position.
 - Switch the ignition off and keep the vehicle key stored safely far enough from the vehicle (especially in vehicles with Keyless Access) so the ignition cannot be inadvertently switched on and the engine started.
 - Always keep children away from the engine compartment and never leave them unattended.
- The engine cooling system is under pressure when the engine is hot. Never open the cap on the coolant expansion tank when the engine is hot. Engine coolant could spray out and cause serious burns or other injuries.
 - Slowly and very carefully turn the cap on the coolant expansion tank counterclockwise while pressing down lightly on the cap.
 - Always protect your face, hands, and arms from hot engine coolant or steam with a large, thick cloth.
- Do not spill any fluids on engine components or the exhaust system when adding fluids. Spilled fluids could cause a fire.

WARNING

The engine compartment contains moving components that can cause serious injuries.

- Never reach into the radiator fan or into the area near the radiator fan. Touching the fan blades could cause serious injuries. The ventilator is temperature-controlled and may switch on by itself even if the ignition is switched off.
- If work must be performed while starting the vehicle or when the engine is running, moving components such as the ribbed belt, alternator, and radiator fan, or the high-voltage system could cause potentially fatal injuries. Always be extremely careful.
 - Always make sure that no parts of the body, jewelry, ties, loose clothing, and long hair can be caught in moving engine components. To reduce the risk of anything becoming caught in engine components, always remove any jewelry and/or ties, tie back long hair, and avoid wearing loose-fitting clothing when performing work.
 - Always press the accelerator pedal extremely carefully and never press it without paying close attention. The vehicle could begin moving, even if the electronic parking brake is set.
- Do not leave any items, such as cleaning cloths or tools, in the engine compartment. Objects left behind can cause malfunctions, engine damage, and fires.

WARNING

Additional insulation, such as covers in the engine compartment, can cause engine malfunctions or fires and result in serious injuries.

- Never cover the engine with blankets or other insulating materials.

Always make sure the vehicle is parked on a solid and level surface before performing any work in the engine compartment ⇒ .

⚠ WARNING

Unintentional vehicle movement while working on the vehicle can cause serious injuries.

- Never work underneath the vehicle when it is not secured to prevent it from rolling. If working under the vehicle with the wheels touching the floor, the vehicle must be on a level surface and the wheels must be secured.
- If you must work underneath the vehicle, additionally support the vehicle securely with suitable stands. The vehicle jack is not sufficient for this because it could collapse, resulting in serious injuries.
- The start-stop system must be manually deactivated.

⚠ WARNING

The high voltage in the electrical system can cause electric shocks, burns, serious injuries, and death.

- Never short-circuit the electrical system. The 12 V vehicle battery could explode.
- To reduce the risk of an electric shock and serious injuries, never touch the electrical wires for the ignition system while the engine is running or being started.
- Never touch the electrical wires and connections of the gas discharge lamps.

Preparing the vehicle for work in the engine compartment

Always perform the following activities in the specified sequence before all work in the engine compartment ⇒ ⚠:

1. Park the vehicle safely on level and stable ground.
2. Press and hold the brake pedal until the engine has stopped.
3. Set the electronic parking brake.
4. Move the selector lever into the **P** position.
5. Stop the engine.
6. If necessary, remove the vehicle key from the vehicle and store it outside of the vehicle so that the vehicle does not start accidentally.
7. Let the engine cool down sufficiently.
8. Always keep other people away from the engine compartment.
9. Secure the vehicle against rolling away.

⚠ WARNING

Failing to follow these instructions, which are provided for your own safety, can cause accidents and serious injuries.

- Always pursue the activities and follow the general safety precautions.

Opening and closing the hood



Fig. 168 In the driver's side footwell: Release lever for the hood (general example).

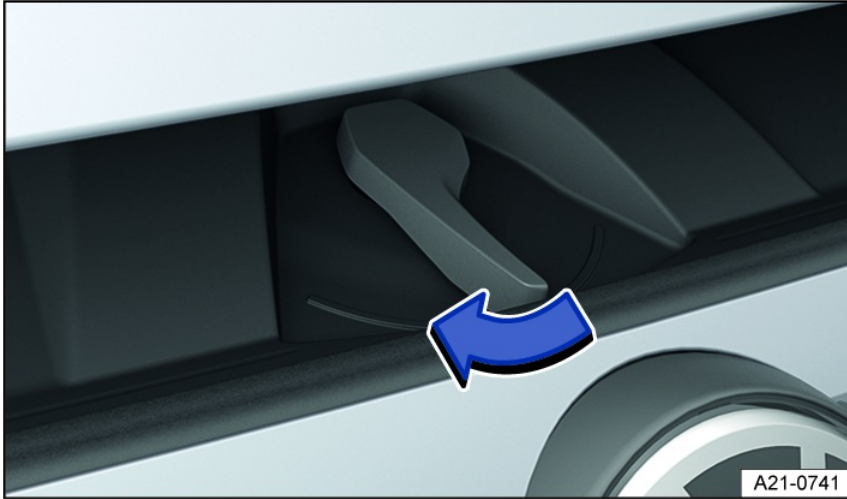

Fig. 169 Above the radiator grille: Opening lever for the hood.

Opening the hood

1. Open the driver door and pull the release lever in the direction of the arrow *fig. 168*.
The hood will pop open from the locking mechanism in the lock carrier ⇒ ⓘ.
2. To open the hood fully, slightly lift the hood while pushing the actuating lever in the direction of the arrow *fig. 169*.
The hood is held open by the gas-pressure strut.

Closing the hood

1. Push the hood down until you override the force of the gas-pressure strut.
2. Let the hood fall into the lock carrier catch from a height of approximately 8 inches (20 cm); do not press it down.
When the hood is closed correctly, it will be flush with the surrounding sections of the vehicle body ⇒ ⚠.

If the hood is not closed correctly, lift the hood up and try to close it again.

If the hood is not correctly closed, an indicator will appear in the display of the Volkswagen Digital Cockpit. Once the hood is correctly closed, the indicator will turn off.

⚠ WARNING

If the hood is not closed correctly, it could open suddenly while driving and block the view through the windshield. This can cause accidents and serious injuries.

- After closing the hood, check that the catch is engaged correctly in the lock carrier.
- If you realize while driving that the hood is not closed correctly, switch on the emergency flashers, carefully apply the brakes, decelerate carefully, stop immediately and close the hood.
- Do not open or close the hood if any persons are in the closing range of the hood.

ⓘ NOTICE

Opening and closing the hood incorrectly can cause damage to the hood and wiper arms.

- Only open the hood when wiper mode is switched off and with the windshield wipers folded in.
- Always fold the wiper arms against the windshield before driving.

Display



Fig. 170 In the instrument cluster display: the hood is open or not closed correctly (general example).

An image in the instrument cluster display indicates if the hood is open or has not closed correctly *fig. 170*.

1.  **Do not continue driving!**
2. If necessary, lift the hood and close it again.

The image is also displayed when the ignition is switched off, and it disappears several seconds after the doors are closed and the vehicle is locked.

WARNING

Disregarding warning notifications could lead to breakdowns while driving, accidents, and serious injuries.

- Never ignore warning notifications.
- Stop the vehicle as soon as it is safe to do so.

 The image may vary depending on the version of the instrument cluster.

Operating fluids and operating equipment

All fluids and operating equipment, such as engine coolant, engine oils and vehicle batteries, are continuously being developed. Have fluids and operating equipment replaced by suitably qualified professionals. Volkswagen recommends contacting an authorized Volkswagen dealer or authorized Volkswagen Service Facility.

WARNING

Unsuitable fluids and operating equipment as well as the incorrect use of them can cause serious injuries and poisoning.

- Only store fluids in their sealed original containers.
- Never use empty food cans, bottles, or other containers to store fluids, because someone could drink the fluids by mistake.
- Keep children away from all fluids and operating equipment.
- Always read and heed the information and warnings on the packaging for the fluids.
- When using products that emit harmful vapors, always work outdoors or in a well-ventilated area.

WARNING

Fluids and some materials in the engine compartment are very flammable and can cause fires and serious injuries.

- Never smoke near the engine compartment.
- Never work near open flames or sparks.
- Never pour or spill fluids on the engine. Fluids could ignite on hot engine components and cause injuries.
- If work must be performed on the fuel system or electrical system, note the following:
 - Always disconnect the 12 V vehicle battery.
Make sure that the vehicle is unlocked when the 12 V vehicle battery is disconnected. Otherwise, the anti-theft alarm system will be activated.
 - Never perform work near sources of heat, boilers, or other open flames.

- Always have a fully-functioning, checked fire extinguisher nearby.

NOTICE

Using incorrect fluids can result in malfunctions and engine damage.

- When filling or changing fluids, make sure the correct fluids are added to the correct reservoirs.

 Fluids leaking from the vehicle can cause environmental damage. Always check the ground under the vehicle for leaking fluids. If you see spots of fluid on the ground under the vehicle, have the vehicle checked by an authorized Volkswagen dealer or authorized Volkswagen Service Facility. Dispose of leaking fluids correctly. Volkswagen recommends contacting an authorized Volkswagen dealer or authorized Volkswagen Service Facility.

Washer fluid

General information



Fig. 171 In the engine compartment: Cap on the washer fluid reservoir (general example).



The windshield washer fluid reservoir is located in the engine compartment. The washer fluid reservoir is identified with the  symbol on the cap [fig. 171](#).

Check the washer fluid level regularly and fill if necessary.

Preparations

1. Prepare the vehicle for work in the engine compartment ⇒ [In the engine compartment](#).
2. Open the hood → page , [Opening and closing the hood](#).

Checking and refilling

1. Check if there is enough washer fluid in the reservoir.
2. To add fluid, mix clean water, not distilled water, with a suitable windshield cleaner. Follow the mixing instructions on the packaging of the windshield cleaner . There is a screen in the filler tube in the windshield washer fluid reservoir. The screen keeps large particles of contaminants from entering the washer nozzles when you refill the washer fluid ⇒ .
3. When the outside temperatures are cold, an anti-freeze agent should be added to the water so that it does not freeze. Follow the mixing instructions on the packaging of the anti-freeze agent.

Depending on the vehicle and vehicle equipment, the washer fluid reservoir capacity is approx. 3.0–7.5 liters (3.1–7.9 quarts).

WARNING

Unsuitable additives in the windshield washer fluid can create an oily film on the vehicle windshield, reduce visibility and increase the risk of accidents and serious injuries.

- Never add coolant additive or similar unsuitable additives to the windshield washer fluid.

! NOTICE

If the screen is damaged or missing, dirt particles could enter the system when adding fluid, which could block the windshield washer nozzles.

- Take the screen out only to clean it.
- Replace a damaged or missing screen.

! NOTICE

An incorrect cleaning agent or mixing of different cleaning agents can cause the components to flocculate and therefore to clog the spray nozzles.

- Only use suitable cleaning agents.
- Never mix different cleaning agents together.

Engine oil

📖 Introduction

The engine oils are determined based on the requirements of the engines, emissions control systems, and the fuel quality. On all combustion engines, the engine oil comes into contact with combustion residue and fuel, which affects the aging of the engine oil. Using the correct engine oil is essential for the function and service life of the engine. The vehicle is filled at the factory with a special multi-purpose, low-viscosity oil that can generally be used year-round.

The vehicle can consume engine oil. The engine oil consumption can vary and can change throughout the service life of the vehicle. Depending on the driving style and the usage conditions, the engine oil consumption can be up to 1 l (1 quart) per 1200 miles (2000 kilometers); it can also be higher within the first 3100 miles (5000 kilometers) on new vehicles. Because of this, the engine oil level must be checked regularly and it is best to check the level before long drives.

⚠ WARNING

Handling engine oil incorrectly can cause severe burns and other injuries.

- Always wear eye protection when handling engine oil.
- Engine oil is poisonous. Always store engine oil out of the reach of children.
- Only store engine oil in its sealed original container. This also applies to used oil until it is disposed.
- Regular contact with engine oil could damage the skin. If engine oil has come into contact with the skin, always wash thoroughly with soap and water.
- Engine oil becomes very hot when the engine is running and can severely burn the skin. Always allow the engine to cool down.

🌿 Engine oil that has dripped and spilled can pollute the environment. Catch any leaking operating fluids and dispose of them correctly according to environmental regulations.

Engine oil standards

📖 Please read the introductory information and heed the Warnings and Notice ⇒ ⚠ Safety precautions for working in the engine compartment.

Utilized engine oil

There is a label on the lock carrier that shows which engine oil should be added. Please follow the note and if possible only add the indicated engine oil ⇒ !.

If this is not possible, contact an authorized Volkswagen dealer or authorized Volkswagen Service Facility to find out which engine oil is suitable for your vehicle. Volkswagen recommends contacting an authorized Volkswagen dealer or authorized Volkswagen Service Facility.

If the engine oil recommended by an authorized Volkswagen dealer or authorized Volkswagen Service Facility qualified in this respect is not available, a different engine oil can be used in an emergency. To reduce the risk of damaging the engine, a maximum of 0.5 liters (0.5 qt) of the following engine oils may be added until the next oil change:

- Gasoline engines: ACEA C3 or API SP standard, viscosity 0 W-30.



! NOTICE

Using engine oils that have not been approved in accordance with the respective VW standard can cause damage to the engine.

- When refilling, only use engine oils that comply with the quality requirements of the respectively applicable VW standard.

🛠 Volkswagen recommends Volkswagen Genuine oil.

Changing the engine oil

 Please read the introductory information and heed the Warnings and Notice ⇒  *Safety precautions for working in the engine compartment.*
The engine oil must be changed regularly in accordance with the instructions in the warranty and maintenance. Your service schedule is supplied with your Manual Service schedule.

Additives in the engine oil can make new engine oil appear dark after a brief engine run time. This is normal and is no reason to change the engine oil more frequently.

WARNING

Changing the engine oil incorrectly can cause environmental damage, fires and serious injuries.

- Always wear eye protection.
- Always allow the engine to cool down to reduce the risk of burns.
- Keep your arms horizontal when using your fingers to unscrew the oil drain plug, so that the draining oil does not drip down your arm.
- Use a container suitable for collecting used oil that can hold at least the entire quantity of oil in the engine.

WARNING

Engine oil is toxic and can cause serious injuries.

- Always store engine oil out of the reach of children.
- Never use empty food cans, bottles or other containers to store engine oil, because individuals may not recognize that they contain engine oil.

NOTICE

Engine oil and filter changes require special tools, technical knowledge and the correct disposal of the used oil.

- For this reason, always have the engine oil and filters changed by an authorized Volkswagen dealer or authorized Volkswagen Service Facility. Volkswagen recommends contacting an authorized Volkswagen dealer or authorized Volkswagen Service Facility.

 Dispose of the engine oil in a way that will not harm the environment and only at a collection point for used oil, e.g. a recycling center or specialist retailer.

Checking the engine oil level and adding oil

 Please read the introductory information and heed the Warnings and Notice ⇒  *Safety precautions for working in the engine compartment.*

Preparations



Fig. 172 In the engine compartment: engine oil filler cap (general example).

To avoid an incorrect oil level reading, perform the following steps:

1. Park vehicles with an engine at operating temperature on a level surface.
2. Wait at least five minutes for the engine oil to flow back into the oil pan.
3. Open the hood.

4. Find the engine oil filler and the dipstick.

You can identify these by the  *fig. 172* symbol on the engine oil filler cap and the colored handle on the oil dipstick.

Checking the engine oil level

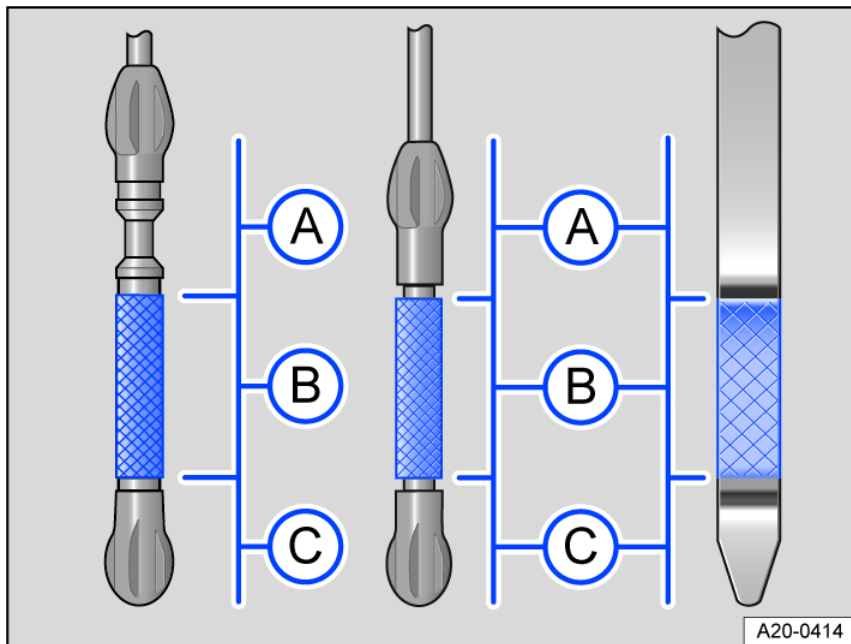



Fig. 173 Engine oil level markings on the oil dipstick (versions).

- A** The engine oil level is too high.
- B** Oil level in the normal range.
- C** The engine oil level is too low.

1. Remove the dipstick from the guide tube and wipe the dipstick off using a clean cloth.

2. Reinsert the dipstick into the guide tube and push it all the way in. If there is an alignment tab on the top of the engine oil dipstick, make sure it lines up with the notch in the guide tube, and that the dipstick goes all the way in.

3. Remove the dipstick again and read the oil level on the dipstick as described below *fig. 173*:

A The engine oil level is too high. If necessary, follow the messages in the instrument cluster display or contact an authorized Volkswagen dealer or authorize Volkswagen Service Facility ⇒ .

B Oil level in the normal range. Engine oil can be added up to the upper edge of this area, for example if there is heavy engine load.

C The engine oil level is too low. Add engine oil immediately.

4. After reading the oil level, reinsert the dipstick back into the guide tube and push it all the way in.

For high vehicle loads, for example when driving long distances on highways in the summer or when driving through high mountains, the engine oil level should be the upper section of the permitted area.

Adding engine oil

WARNING

Engine oil can ignite if it comes into contact with hot engine components. This can cause burns and serious injuries.

- Always make sure that the engine oil cap is installed securely on the engine filler opening after adding oil and that the oil dipstick is inserted correctly in the guide tube. This can prevent engine oil from leaking and coming into contact with hot engine components when the engine is running.
- If engine oil spills on cold engine components, it could heat up and ignite when the engine is running.

Only perform these activities in the specified order ⇒  ⇒ :



1. Remove the cap on the engine oil filler *fig. 172*.

2. Top up the engine oil gradually in small quantities, not more than 0.5 l (0.5 quart), or follow the recommendation in the display of the Volkswagen Digital Cockpit. Volkswagen recommends using the approved engine oils in accordance with the respective VW standard.

3. To avoid overfilling, you must wait at least one minute each time you add engine oil so that the engine oil can flow into the oil pan up to the marking on the oil dipstick.

4. Read the oil level on the dipstick again before adding a little more. Never add too much oil.

When you are done adding oil, the oil level should be in the center of area *fig. 173* **B**. The engine oil level must not be in the area *fig. 173* **A**.

5. If you accidentally add too much engine oil and the engine oil level is in area *fig. 173* , do not start the engine ⇒ . Contact an authorized Volkswagen dealer or authorized Volkswagen Service Facility for assistance.
6. Close the cap on the engine oil filler when you are done adding engine oil.
7. Insert the oil dipstick all the way into the guide tube. If there is an alignment tab on the top of the engine oil dipstick, make sure it lines up with the notch in the guide tube, and that the dipstick goes all the way in.
8. Close the hood.

CAUTION

If the engine oil level is too high after refilling, this can cause engine damage.

- Do not start the engine, and seek professional assistance.

NOTICE

Using incorrect fluids can result in malfunctions and engine damage.

- When topping up fluids, make sure the correct fluids are added to the correct reservoirs.

 Volkswagen recommends using the approved engine oils in accordance with the respective VW standard.

 If you are not sure where the cap and the oil dipstick are located, contact an authorized Volkswagen dealer or authorized Volkswagen Service Facility for assistance. Volkswagen recommends contacting an authorized Volkswagen dealer or authorized Volkswagen Service Facility.

Troubleshooting

 Please read the introductory information and heed the Warnings and Notice ⇒  *Safety precautions for working in the engine compartment.*

Engine oil pressure too low

The red warning light blinks. A message is shown in the instrument cluster display.

 **Do not continue driving!** Engine damage could result.

1. Stop the vehicle as soon as it is safe to do so ⇒ *Parking*.
2. Stop the engine.
3. Check the engine oil level ⇒ *Checking the engine oil level and adding oil*.
4. If the warning light flashes, do not continue driving or let the engine run, even if the oil is at the correct level. Engine damage could result. Contact an authorized Volkswagen dealer or authorized Volkswagen Service Facility for assistance.

Engine oil level very low

The red warning light blinks. A message is shown in the instrument cluster display.

 **Do not continue driving!** Engine damage could result.

1. Stop the vehicle as soon as it is safe to do so ⇒ *Parking*.
2. Stop the engine.
3. Check the engine oil level ⇒ *Checking the engine oil level and adding oil*.
4. If necessary, top up the engine oil gradually in small quantities (not more than 0.5 l (0.5 qt) in total) or observe the top-up recommendation in the display of the Volkswagen Digital Cockpit.
5. If the warning light lights up, do not continue driving or let the engine run, even if the oil is at the correct level. Engine damage could result. Contact an authorized Volkswagen dealer or authorized Volkswagen Service Facility for assistance.

Engine oil level too low

The yellow indicator light turns on. A message is shown in the instrument cluster display.

1. Stop the vehicle as soon as it is safe to do so ⇒ *Parking*.
2. Stop the engine.
3. Check the engine oil level ⇒ *Checking the engine oil level and adding oil*.
4. If necessary, top up the engine oil gradually in small quantities (not more than 0.5 l (0.5 qt) in total) or observe the top-up recommendation in the display of the Volkswagen Digital Cockpit.
5. If the indicator light comes on, do not continue driving or let the engine run, even if the oil is at the correct level. Engine damage could result. Contact an authorized Volkswagen dealer or authorized Volkswagen Service Facility for assistance.

Engine oil level too high

The yellow indicator light turns on. A message is shown in the instrument cluster display.

1. Stop the vehicle as soon as it is safe to do so ⇒ *Parking*.
2. Stop the engine.
3. Check the engine oil level ⇒ *Checking the engine oil level and adding oil*.
4. If the engine oil level is too high, do not drive any further or leave the engine running. Engine damage could result. Contact an authorized Volkswagen dealer or authorized Volkswagen Service Facility for assistance.

or Engine oil system malfunction

The indicator light flashes yellow. A message is shown in the instrument cluster display.

1. Contact a suitably qualified professional. Volkswagen recommends contacting an authorized Volkswagen dealer or authorized Volkswagen Service Facility.

Engine coolant

Introduction

Only perform work on the engine cooling system if you are familiar with the necessary activities and the general safety precautions, and if the correct operating equipment, fluids and suitable tools are available. Work performed incorrectly can result in serious injuries ⇒ . Have all work performed by suitably qualified professionals if necessary. Volkswagen recommends contacting an authorized Volkswagen dealer or authorized Volkswagen Service Facility.

Information about warning and indicator lights can be found in the troubleshooting section at the end of the chapter ⇒ *Troubleshooting*.

WARNING

Engine coolant is poisonous!

- Only store engine coolant in the sealed original container and in a secure place.
- Never use empty food cans, bottles, or other containers to store engine coolant, because someone could drink the engine coolant by mistake.
- Store engine coolant out of the reach of children.
- Make sure that the correct proportion of engine coolant additive is provided based on the lowest ambient temperature in which the vehicle will be operated.
- In extremely low temperatures, the coolant can freeze and the vehicle could break down. Because the heater will also no longer function in that situation, vehicle occupants could die of exposure if they do not have sufficient warm clothing.

 Coolant and coolant additives can pollute the environment. Catch any leaking operating fluids and dispose of them correctly according to environmental regulations.

Engine coolant specifications

 Please read the introductory information and heed the Warnings and Notice ⇒  *Safety precautions for working in the engine compartment*.

The cooling system is filled at the factory with a mixture of specially prepared water and at least 40% coolant additive G12evo (TL 744-L).

To protect the engine cooling system, there must always be at least a 40% proportion of coolant additive. If greater freeze protection is needed due to the climate, the proportion of coolant additive can be increased. However, the proportion of coolant additive must not exceed 55 %, because otherwise the freeze protection will be reduced and the cooling effect will be decreased.

The engine coolant additive can be recognized by its violet color. The mixture of water and coolant additive provides freeze protection down to -13 °F (-25 °C), protects the aluminum alloy parts of the cooling system from corrosion, prevents limescale deposits, and increases the boiling point of the coolant.

If the engine coolant is being topped up, a blend of distilled water and at least 40% of the G12evo engine coolant additive must be used to ensure optimum corrosion protection ⇒ .

CAUTION

Insufficient freeze protection in the cooling system can cause engine malfunctions, which can result in injuries.

- Only use coolant additive approved by the manufacturer.
- Make sure the coolant additive is adjusted according to the ambient temperature.
- In extremely low temperatures, the coolant can freeze and the vehicle could break down. Because the heater will also no longer function in that situation, vehicle occupants could die of exposure if they do not have sufficient warm clothing.

NOTICE

The coloring of the engine coolant results from the mixture of the purple coolant additive and distilled water. If the fluid in the coolant expansion tank is not purple, but for example brown, the engine coolant has been mixed with another non-suitable coolant.

Serious malfunctions or damage to the engine and cooling system could occur!

- Immediately have the engine coolant changed by suitably qualified professionals. Volkswagen recommends contacting an authorized Volkswagen dealer or authorized Volkswagen Service Facility.
- Never mix Genuine Volkswagen coolant additives with coolants that are not approved by Volkswagen when topping up.

 Engine coolant and coolant additives can harm the environment. Catch any leaking operating fluids and dispose of them correctly according to environmental regulations.

Checking and filling engine coolant

 Please read the introductory information and heed the Warnings and Notice \Rightarrow  *Safety precautions for working in the engine compartment.*

Preparations

1. Parking the vehicle on a level, secure surface.
2. Allow the engine to cool \Rightarrow .
3. Open the hood.

The coolant expansion tank is identified with the  red symbol on the cap *fig. 174*.



Fig. 174 In the engine compartment: cap on the engine coolant expansion tank.

WARNING

Hot steam and hot engine coolant can cause serious burns.

- Never open the engine hood if you can see or hear steam or coolant escaping from the engine compartment. Wait until you can no longer see or hear steam or coolant escaping. Hot components can cause burns if touched.

WARNING

The engine cooling system is under pressure when the engine is hot. Never open the cap on the coolant expansion tank when the engine is hot. Engine coolant could spray out and cause serious burns or other injuries.

- Slowly and very carefully turn the cap counterclockwise while pressing down lightly on the cap.
- Always protect your face, hands, and arms from hot coolant or steam by placing a large, thick cloth on the coolant expansion tank cap.

Checking the coolant level



Fig. 175 In the engine compartment: markings on the engine coolant expansion tank.

When new vehicles are delivered or after repairs to the cooling system, the coolant level may be above the marked area. This is normal. The coolant does not need to be extracted.

The coolant level cannot be checked exactly for every model, because the view of the fluid level in the coolant expansion tank may be obstructed. If you cannot read off the engine coolant level accurately, contact a suitably qualified professional. Volkswagen recommends contacting an authorized Volkswagen dealer or authorized Volkswagen Service Facility.

1. When the engine is cold, check the coolant level using the markings on the side of the engine coolant expansion tank *fig. 175*.

The coolant level must be between the markings.

2. If the fluid level in the coolant expansion tank is below the minimum mark ("min"), have coolant added.

When the engine is warm, the engine coolant level may be slightly above the upper marking.

3. If no coolant is visible in the coolant expansion tank, do not add coolant ⇒ .

Filling the coolant

1. Carefully unscrew the cap ⇒ .

2. Only add new coolant that conforms to the Volkswagen specification ⇒ *Engine coolant specifications*.

If there is no engine coolant available that conforms to the required specification, initially only top up with distilled water. Then have the correct mixture ratio using the specified coolant additive restored as soon as possible by an authorized Volkswagen dealer or authorized Volkswagen Service Facility. Volkswagen recommends contacting an authorized Volkswagen dealer or authorized Volkswagen Service Facility ⇒ .

3. Top up the engine coolant to the upper fill level marker.

After topping up the engine coolant, the coolant level must be between the markings on the coolant expansion tank *fig. 175*.

4. Install the cap securely.

5. Check the coolant level after one day. If the level of the engine coolant tank drops below the "min" minimum marking again, contact an authorized Volkswagen dealer or authorized Volkswagen Service Facility and have the cooling system checked. Volkswagen recommends contacting an authorized Volkswagen dealer or authorized Volkswagen Service Facility.

6. If there is no engine coolant available that conforms to the specification, do not use any other engine coolant additive in an emergency ⇒ .

NOTICE

If there is too much engine coolant, it will escape from the cooling system under high pressure when the coolant warms up, which can result in damage.

- Do not refill the system with engine coolant above the upper edge of the marked area.

NOTICE

If there is no more engine coolant in the coolant expansion tank, air can get into the cooling system. This could result in damage to the engine.

- Stop driving and do not top up with engine coolant.
- See an authorized Volkswagen dealer or authorized Volkswagen Service Facility for assistance.

! NOTICE

The chemical components contained in water that is not distilled can cause considerable corrosion damage in the engine. This can cause engine malfunctions.

- Only use distilled water for refilling the system!
- If water that is not distilled is added, have the fluid in the cooling system changed immediately by a qualified workshop. Volkswagen recommends contacting an authorized Volkswagen dealer or authorized Volkswagen Service Facility.

! NOTICE

The use of incorrect fluids can cause serious malfunctions and damage to the engine.

- When topping up fluids, make sure the correct fluids are added to the correct reservoirs.

Troubleshooting

 Please read the introductory information and heed the Warnings and Notice ⇒  *Safety precautions for working in the engine compartment.*

Engine coolant

The red warning light blinks. The coolant temperature is too high or the coolant level is too low.

 **Do not continue driving!** Engine damage could result.

1. Stop the vehicle as soon as it is safe to do so ⇒ *Parking.*
2. Stop the engine.
3. Allow the engine to cool.
4. Check the engine coolant level on the Coolant expansion tank ⇒ *Checking and filling engine coolant.*
5. If the warning light does not turn off, do not continue driving or let the engine run, even if the engine coolant is at the correct level.
6. Contact an authorized Volkswagen dealer or authorized Volkswagen Service Facility for assistance.

Brake fluid

Introduction

Brake fluid absorbs moisture from the air over the course of time. Too much water in the brake fluid causes damage to the brake system. Water lowers the boiling point of the brake fluid. If the water content in the brake fluid is too high, vapor lock may form in the brake system during heavy braking and full braking. Vapor lock reduces the braking efficiency, increases the braking distance considerably, and can lead to a total failure of the brake system. Your own safety and the safety of others on the road depends on your brake system functioning correctly at all times.

WARNING

Brake fluid is poisonous.

- To reduce the risk of poisoning, never store brake fluid in beverage containers or other containers. A person could mistakenly drink from the container, even if the container is marked.
- Always store brake fluid in the sealed original container and keep it out of the reach of children.

! NOTICE

Spilled or leaking brake fluid damages vehicle paint and tires.

- Immediately wipe up any spilled or leaking brake fluid that comes into contact with vehicle components.

 Brake fluid can pollute the environment. Collect spilled brake fluid and dispose of it correctly.

Brake fluid specifications

 Please read the introductory information and heed the Warnings and Notice ⇒  *Safety precautions for working in the engine compartment.*

Volkswagen has developed a special brake fluid that is optimized for the vehicle's brake system. For optimum performance of the brake system, Volkswagen recommends only using brake fluid that complies with the "VW standard 501 14".

Before using brake fluid, check that the brake fluid specification on the bottle matches the vehicle requirements.

Brake fluid that complies with the VW standard 501 14 can be obtained from an authorized Volkswagen dealer or authorized Volkswagen Service Facility.

If brake fluid that meets this specification is not available and another high-quality brake fluid must therefore be used, brake fluid that complies with the specification

DIN ISO 4925 or the US Standard FMVSS 116 DOT 4 CLASS 6 can be used.

Not all brake fluids that comply with the requirements of DIN ISO 4925 or US Standard FMVSS 116 DOT 4 CLASS 6 have the same chemical composition. Some of these brake fluids can contain chemicals that can destroy or damage components of the vehicle brake system over time.

To help ensure that the brake system functions correctly over the long term, Volkswagen recommends using a brake fluid that expressly conforms to the "VW standard 501 14".

Brake fluid that complies with the VW standard 501 14 meets the requirements of DIN ISO 4925 or the US Standard FMVSS 116 DOT 4 CLASS 6.

Checking the Brake Fluid

📖 Please read the introductory information and heed the Warnings and Notice ⇒ ⚠️ *Safety precautions for working in the engine compartment.*

Preparations

1. Parking the vehicle on a level, secure surface.
2. Open the hood.

Checking the Brake Fluid Level



Fig. 176 In the engine compartment: cap on the brake fluid reservoir (version 1).



Fig. 177 In the engine compartment: cap on the brake fluid reservoir (version 2).

The brake fluid reservoir can be recognized by its cap [fig. 176](#) or [fig. 177](#).

The brake fluid level cannot be checked precisely on all models because the hood or engine components may obstruct the view of the fluid level in the reservoir. If you cannot read the brake fluid level clearly, see an authorized Volkswagen dealer or authorized Volkswagen Service Facility for assistance. Volkswagen recommends contacting an authorized Volkswagen dealer or authorized Volkswagen Service Facility.

The brake fluid level must always be between the MIN and MAX markings on the brake fluid reservoir ⇒ ⚠️.

The brake fluid level decreases slightly when the vehicle is being used as the brake pads wear and the brakes automatically adjust themselves.

Changing brake fluid

Have the brake fluid changed regularly. An authorized Volkswagen dealer or authorized Volkswagen Service Facility can provide information about the interval for changing the vehicle brake fluid. Only have brake fluid added that meets the required specifications. Volkswagen recommends contacting an authorized Volkswagen dealer or authorized Volkswagen Service Facility.

WARNING

Low brake fluid, brake fluid that is too old, or using an incorrect type of brake fluid can cause brake malfunctions or reduced braking efficiency. Hard braking when the brake fluid is old can cause vapor lock to form in the fluid due to absorbed moisture. Vapor lock reduces the braking efficiency, increases the braking distance considerably, and can lead to a total failure of the brake system.

- Have the brake system and brake fluid level checked or have the brake fluid changed regularly.
- Only have new brake fluid added.
- Be sure to use the correct brake fluid. Only use brake fluid that expressly complies with the VW standard 501 14. Any other brake fluid or brake fluid that is not high-quality can impair the braking function and reduce the braking efficiency.
- If brake fluid that complies with the VW standard 501 14 is not available and it is absolutely necessary to use a different brake fluid, only use a high-quality brake fluid that complies with DIN ISO 4925 CLASS 6 or US standard FMVSS 116 DOT 4.

Troubleshooting

 Please read the introductory information and heed the Warnings and Notice ⇒  Safety precautions for working in the engine compartment.

BRAKE Brake fluid level

The red warning light turns on. The brake fluid level is too low.

 **Do not continue driving!** This could result in the brake failing.

1. Stop the vehicle immediately as soon as it is safe to do so ⇒ *Parking*.
2. Check the brake fluid level.
3. If the brake fluid level is too low, contact an authorized Volkswagen dealer or authorized Volkswagen Service Facility.

12 V vehicle battery

Introduction

The 12-volt vehicle battery is a component of the electrical system and serves to supply energy to the vehicle. During maintenance procedures, the 12 V vehicle battery is checked and replaced if necessary.





You may only perform procedures on the electrical system yourself if you are familiar with the necessary activities and the general safety precautions, and if the correct operating equipment and fluids and suitable tools are available. Work performed incorrectly can result in serious injuries ⇒ . Have all work performed by suitably qualified professionals. Volkswagen recommends contacting an authorized Volkswagen dealer or authorized Volkswagen Service Facility.

Information about warning and indicator lights can be found in the troubleshooting section at the end of the chapter ⇒ *Troubleshooting*.

Battery switch-off in an accident with triggering of the airbag

In vehicles with a 12 V vehicle battery in their vehicle interior or luggage compartment, the electrical connection to the 12 V vehicle battery is pyrotechnically disconnected in an accident with airbag deployment. This prevents a short circuit. For more information on the installation location of the vehicle battery, refer to section → page , *Checking the 12 V vehicle battery acid level* .

Detailed warnings for the 12 V vehicle battery

 Always wear eye protection.  Battery acid is highly corrosive. Always wear protective gloves and eye protection.  Fire, sparks, open flame, and smoking are forbidden.  A highly explosive mixture of gases forms when charging the 12 V vehicle battery.  Always keep children away from battery acid and the 12 V vehicle battery.  Always heed the Owner's Manual.

WARNING

Performing work on the 12 V vehicle battery and the electrical system can cause serious injuries, fires, or electric shocks.

- Always read and observe the following warnings and safety precautions.
- Before performing any work on the 12 V vehicle battery, switch off the ignition and all electrical equipment and disconnect the 12 V battery negative cable.
- Always keep children away from battery electrolyte and the 12 V vehicle battery.
- Always wear eye protection and safety gloves.
- When handling 12 V vehicle batteries, always protect your hands, arms, and face from spraying battery acid.

- Never short circuit the battery terminals.
- Never use a damaged 12 V vehicle battery. Replace a damaged 12 V vehicle battery immediately.
- Never use a frozen 12 V vehicle battery. A drained 12 V vehicle battery can freeze at temperatures around 32 °F (0 °C). Replace the 12 V vehicle battery immediately.

WARNING

When working on the 12 V vehicle battery, a highly explosive mixture of gas builds up, which is flammable and can cause serious injuries. Sparks could form and ignite the flammable gas that is released by the 12 V vehicle battery.

- Always keep fires, sparks, open flames, and lit cigarettes far away from the 12 V vehicle battery.
- Avoid creating sparks when working with wires and electrical equipment or when discharging static electricity.

WARNING

California Proposition 65 Warning.

- This product can expose you to chemicals including lead and lead components, which are known to the State of California to cause cancer and birth defects or other reproductive harm. For more information go to www.P65Warnings.ca.gov.

NOTICE

UV rays can damage the battery housing.

- Do not expose the 12 V vehicle battery to direct sunlight for a long period of time.

NOTICE

The 12 V vehicle battery could freeze and be destroyed.

- Protect the 12 V vehicle battery against freezing temperatures if the vehicle is parked for long periods of time.

 **After starting the engine when the 12-volt vehicle battery is severely drained or when it has been replaced or jump-started, the system settings (time, date, personal convenience settings, and programming) and user profiles may be changed or erased. Check and correct the settings after the 12 V vehicle battery is sufficiently recharged.**

Checking the 12 V vehicle battery acid level

 Please read the introductory information and heed the Warnings and Notice ⇒  **Safety precautions for working in the engine compartment.**

Check the acid level of the 12 V vehicle battery regularly if mileage is high, in countries with warm climates, or if the 12 V vehicle battery is old. Otherwise, the 12 V vehicle battery is maintenance-free.

12 V vehicle battery location

The 12 V vehicle battery may be located in the engine compartment or under/behind a cover in the luggage compartment, depending on the vehicle equipment.

Preparations

1. Prepare the vehicle for work in the engine compartment.
2. Wear suitable eye protection and safety gloves.
3. Open the hood.

Check the battery acid status for vehicles with a 12 V vehicle battery in the engine compartment

WARNING

Performing work on the 12 V vehicle battery can cause serious injuries to skin and eyes, explosions or electric shocks.

- Never use open flames or smoldering objects to provide lighting.
- When handling 12 V vehicle batteries, always protect your hands, arms, and face from spraying battery acid.
- Never open a 12 V vehicle battery.
- Never tilt the 12 V vehicle battery. Acid can leak out of the vent openings.
- If battery acid comes into contact with the skin or eyes, rinse the affected area immediately with cold water for several minutes. Then consult a doctor immediately.
- Consult a doctor immediately if battery acid is swallowed.

Depending on the vehicle equipment, an additional bracket must be removed to see the viewing window. An additional tool that is not available in the vehicle tool kit is required to do this. Always have the acid level of the 12 V vehicle battery checked by an authorized Volkswagen dealer or authorized Volkswagen Service Facility. Volkswagen recommends contacting an authorized Volkswagen dealer or authorized Volkswagen Service Facility.



Fig. 178 On the top of the 12 V vehicle battery: Window (general example).

Make sure there is enough lighting to clearly see the color indicator in the circular window on the top of the 12 V vehicle battery [fig. 178](#).

The color indicator in the circular window changes depending on the acid level in the 12 V vehicle battery.

Light yellow or colorless The 12 V vehicle battery acid level is too low. Have the 12 V vehicle battery replaced by an authorized Volkswagen dealer or authorized Volkswagen Service Facility. Volkswagen recommends contacting an authorized Volkswagen dealer or authorized Volkswagen Service Facility.

Black The 12 V vehicle battery acid level is OK.

The acid level of 12 V vehicle batteries labeled AGM cannot be checked for technical reasons. Suitably qualified professionals can inspect the battery. Volkswagen recommends contacting an authorized Volkswagen dealer or authorized Volkswagen Service Facility.

Checking the battery acid status for vehicles with a 12 V vehicle battery in the luggage compartment

For technical reasons, it is not possible to check the acid level in vehicles with a 12 V vehicle battery in the luggage compartment. To have the 12-volt vehicle battery checked, contact an authorized Volkswagen dealer or authorized Volkswagen Service Facility. Volkswagen recommends contacting an authorized Volkswagen dealer or authorized Volkswagen Service Facility.

Charging, replacing, disconnecting, or connecting the 12 V vehicle battery

Please read the introductory information and heed the Warnings and Notice ⇒ **Safety precautions for working in the engine compartment.**

If you suspect that the 12 V vehicle battery is damaged or malfunctioning, see suitably qualified professionals to have the 12 V vehicle battery checked. Volkswagen recommends contacting an authorized Volkswagen dealer or authorized Volkswagen Service Facility.

Charging the 12 V vehicle battery

The 12 V vehicle battery should be charged by suitably qualified professionals because the 12 V vehicle battery that is installed at the factory requires a charging process where the voltage is limited ⇒ . Volkswagen recommends contacting an authorized Volkswagen dealer or authorized Volkswagen Service Facility.

Replacing the 12 V vehicle battery

The 12 V vehicle battery is designed to fit the location where it is installed and is equipped with safety features. If a 12 V vehicle battery needs to be replaced, have the replacement part fitted by qualified professionals. Volkswagen recommends contacting an authorized Volkswagen dealer or authorized Volkswagen Service Facility. Check with qualified professionals to find out the component information regarding size and the required maintenance, performance, and safety features. They must possess the necessary technical documentation and equipment. Volkswagen recommends contacting an authorized Volkswagen dealer or authorized Volkswagen Service Facility. The vent opening on the 12 V vehicle battery must always be located on the negative terminal side. The vent opening on the positive terminal side must always be sealed ⇒ .

Only use a maintenance-free 12 V vehicle battery that conforms to the TL 825 06 and VW 7 50 73 standards. These standards must be from October 2014 or later.

Always have the 12 V vehicle battery replaced by qualified professionals because the vehicle electronics must be adapted as part of the replacement. Only qualified professionals have the necessary equipment to perform the adaptation and have access to the correct replacement batteries.

Disconnecting the 12 V vehicle battery

If the 12 V vehicle battery must be disconnected from the vehicle electrical system, note the following:

1. Switch off all electrical consumers.
2. Unlock the vehicle before disconnecting the battery. Otherwise, the anti-theft alarm system will be triggered.
3. Disconnect the negative cable first, and then the positive cable ⇒ .

Connecting the 12 V vehicle battery

If the 12 V vehicle battery must be connected to the vehicle electrical system, note the following:

1. Switch off all electrical consumers.
2. Connect the positive cable first, and then the negative cable ⇒ .

Various indicator lights may turn on after connecting the 12 V vehicle battery and switching the ignition on. They will turn off after driving a short distance at a speed of approximately 10–12 mph (15–20 km/h). If the indicator lights light up and remain on, contact an authorized Volkswagen dealer or authorized Volkswagen Service Facility and have the vehicle checked. Volkswagen recommends contacting an authorized Volkswagen dealer or authorized Volkswagen Service Facility.

If the 12 V vehicle battery was disconnected for a long period of time, the next scheduled maintenance may not display correctly or it may not be calculated correctly ⇒ [Service interval display](#). Follow the maximum permissible maintenance interval ⇒ [Maintenance](#).

Vehicles with a starter button: If the ignition cannot be switched on after connecting the 12 V vehicle battery, carry out the following activities:

1. Lock and unlock the vehicle from the outside.
2. Try to switch the ignition on again.
3. If the ignition will not switch on, see an authorized Volkswagen dealer or authorized Volkswagen Service Facility for assistance.

Automatic equipment deactivation

If the ignition is switched on for a very long time when the engine is off or the parking light is switched on when parking for a very long time, the intelligent power management cannot always prevent the 12 V vehicle battery from being drained.

If the 12 V vehicle battery is under a heavy load, the intelligent power management will automatically begin certain measures to prevent the 12 V vehicle battery from draining.

- The idle speed will be increased so that the alternator delivers more power.
- If necessary, equipment that uses a lot of power will have its performance limited or will be switched off.
- The power supply to the 12 V socket will be interrupted temporarily when the engine is started.

12 V Vehicle Battery Draining

If the battery is drained, it may not be possible to start the engine. The 12 V vehicle battery will be drained in the following situations:

- If the vehicle is parked for long periods of time without running the engine, especially if the ignition is on.
- If electrical equipment is used when the ignition is switched off.

WARNING

Securing the vehicle battery incorrectly or using the wrong 12 V vehicle battery can cause short circuits, fires, and serious injuries.

- Always use maintenance-free and leak-proof 12 V vehicle batteries that have the same characteristics, specifications, and dimensions as the 12 V vehicle battery that was installed at the factory.

WARNING

A highly explosive mixture of hydrogen gas can form when charging the 12 V vehicle battery.

- Only charge 12 V vehicle batteries in well-ventilated areas.
- Never charge a frozen or thawed 12 V vehicle battery. A drained 12 V vehicle battery can freeze at temperatures around 32 °F (0 °C).
- Always replace the 12 V vehicle battery if it freezes.

WARNING

A highly explosive mixture of gas forms in the 12 V vehicle battery when operating the vehicle.

- For vehicles with the 12 V vehicle battery in the vehicle interior or luggage compartment, ensure that the degassing hose is connected to the 12 V vehicle battery correctly. The degassing hose must always be connected to the negative terminal side of the 12-volt vehicle battery. If there is an opening on the positive terminal side of the 12-volt vehicle battery, it must always be capped.

CAUTION

Cables that are connected incorrectly can cause a short circuit. This may damage the on-board electronics.

- Connect the positive cable first and then the negative cable.

! NOTICE

The electrical system or electrical components could be damaged and electrical malfunctions could result.

- Never connect or disconnect the 12 V vehicle batteries when the ignition is on or the engine is running.
- Never connect accessories that provide power, such as solar panels or battery chargers, to the 12 V socket in order to charge the 12 V vehicle battery.
- Never use a 12 V vehicle battery that does not conform to the vehicle specifications.

 12 V vehicle batteries can contain toxic substances such as sulfuric acid and lead. Dispose of 12 V vehicle batteries correctly.

 Battery acid can pollute the environment. Collect spilled battery acid and dispose of it correctly.

Troubleshooting

 Please read the introductory information and heed the Warnings and Notice ⇒  *Safety precautions for working in the engine compartment.*

12-volt power supply

The red warning light turns on. A message is shown in the instrument cluster display.

 **Do not continue driving!** Possible failure of the electrical system.

1. Stop the vehicle immediately and park it safely.
2. Turn off electrical equipment that is not needed.
3. Switch the ignition off.
4. Contact an authorized Volkswagen dealer or authorized Volkswagen Service Facility for assistance.

If the red warning light comes on, the start-stop system is switched off. The start-stop system will only be automatically switched on again after the engine is restarted.

12-volt power supply

The yellow indicator light turns on. A message is shown in the instrument cluster display.

Messages about the battery charge level of the 12 V vehicle battery.

1. Let the engine run so that the 12 V vehicle battery can be recharged.
2. If the message about the battery charge level of the 12 V vehicle battery does not turn off after a few minutes despite the measures having been taken, then contact an authorized Volkswagen dealer or authorized Volkswagen Service Facility.

Messages about the 12 V power supply.

1. Contact an authorized Volkswagen dealer or authorized Volkswagen Service Facility for assistance.

If the yellow indicator light lights up, the start-stop system will not be able to start the engine. If the yellow indicator light has turned off, the 12 V vehicle battery has sufficient battery charge level to automatically restart the engine.

Wheels and tires

Introduction

Tires are the part of the vehicle that are under the most demand yet are the most underestimated. Tires are extremely important, because the small running surface on the tires is the only point of contact that the vehicle has with the road.

The tire and rim combinations approved by Volkswagen are specifically designed for each other.

The service life of the tire depends on the tire pressure, the driving style, the way the tires are handled, and correct mounting of the tire.

Rims, tires and wheel bolts

Rims, tires, and wheel bolts are determined based on the vehicle model. Whenever another rim is installed, the wheel bolts to be used must have the correct length and bolt head shape. This ensures that the brakes can work correctly and that the vehicle drives smoothly and safely. For technical reasons, standard rims from other vehicles cannot be used. Under certain circumstances, this may even apply to rims for the same vehicle model. You must consult a suitably qualified professional to replace rim/tire combinations. Volkswagen recommends contacting an authorized Volkswagen dealer or authorized Volkswagen Service Facility.

The correct wheel bolts must always be used for each vehicle model, and these bolts must always be tightened to the correct torque → [Wheel bolts](#).

WARNING

New tires or tires that are old, worn, or damaged cannot provide the maximum vehicle control and braking effect.

- Handling wheels and tires incorrectly can reduce driving safety and cause accidents and serious injuries.
- For all four wheels, use only radial tires of the same design, size (rolling circumference), and tread pattern.
- You must break in new tires because they have reduced traction and braking efficiency when they are new. To reduce the risk of accidents and serious injuries, drive carefully during the first 370 miles (600 km).
- Regularly check the tire pressure when the tires are cold and always maintain the specified pressure. If the tire pressure is too low, the tire can heat up so much while driving that the tread separates or the tire ruptures.
- Check the tires regularly for damage and wear.
- Never drive with tires that are damaged (punctured, cut, cracked, or bulging) or worn. Driving with tires in this condition can cause tire blowouts, accidents, and serious injuries. Replace worn or damaged tires immediately.
- Never exceed the maximum permissible speed and tire load specified for the tires fitted to your vehicle.
- The effectiveness of the driver assistance systems and the braking assistance systems depends on tire traction.
- If there are unusual vibrations or if the vehicle pulls to one side while driving, stop immediately and check the wheels and tires for damage.
- To reduce the risk of loss of vehicle control, accidents, and serious injuries, never loosen the bolts on rims with a bolted rim ring.
- Do not use any wheels or tires if you do not know how they have been used in the past. Used wheels and tires may be damaged, even if this damage is not visible, and could lead to tire damage, tire failure or loss of vehicle control.
- Old tires can lose pressure suddenly at high speeds or fail and cause accidents and serious injuries. This is true even if the tires have not been used yet. Only use tires that are more than six years old if absolutely necessary and drive with extreme caution if doing so.

WARNING

If the wheel bolts are not tightened correctly or are missing, the wheels could become loose and lead to loss of vehicle control, accidents, and serious injuries.

- Never drive with missing or loose wheel bolts.
- Always use wheel bolts that are correct for the rim and the vehicle model.
- Always tighten the wheel bolts to the correct tightening torque. If you do not have a torque wrench, tighten the wheel bolts with the lug wrench and then have the tightening torque checked as soon as possible by an authorized Volkswagen dealer or authorized Volkswagen Service Facility. Volkswagen recommends contacting an authorized Volkswagen dealer or authorized Volkswagen Service Facility.

WARNING

Improper installation of the tires on the rim can cause tires to suddenly lose air or go flat while driving and damage the rim. This can cause accidents and fatal injuries.

- Always have tires installed on the rim by an authorized Volkswagen dealer or authorized Volkswagen Service Facility. Volkswagen recommends contacting an authorized Volkswagen dealer or authorized Volkswagen Service Facility.

Taking care of wheels and tires

Handling tires

Preventing damage to the tires

- Always drive over curbs and other low obstacles slowly and at a right-angle so that both front wheels come into contact with the obstacle at the same time.
- Check the tire pressure regularly.
- Check tires regularly for damage, e.g. punctures.
- Never exceed the load index and maximum speed of the tire ⇒ [Tire labeling and tire classifications](#).
- Have damaged or worn rims replaced immediately ⇒ [Troubleshooting](#).
- Protect tires from coming into contact with corrosive materials such as grease, oil, gasoline, and brake fluid ⇒ .
- Replace missing dust caps on the valves immediately.
- Remove any objects provided they have not punctured the inside of the tire ⇒ [Troubleshooting](#).
- Pay attention to all warnings issued by the Tire Pressure Monitoring System ⇒ [Troubleshooting the Tire Pressure Monitoring System](#).

WARNING

Corrosive fluids and materials can cause visible and invisible damage to the tires, which can cause the tires to fail.

- Always keep chemicals, oils, grease, fuel, brake fluid, and other corrosive materials away from the tires.

Storing tires

- Only store tires in a cool, dry location that is as dark as possible.
- Do not stand tires that are mounted on rims up vertically.
- Protect tires that are not mounted on rims from dirt with suitable covers and store them standing on the tread surface.

Tires that are more than six years old

Tires age due to physical and chemical processes that affect their function. Tires that have been stored and unused for long periods of time age more quickly than tires that are used continuously.

Volkswagen recommends replacing tires that are more than six years old with new tires. This even applies to tires that may appear to be usable and whose tread depth is still greater than the minimum requirement ⇒ .

Winter and all season tires lose their characteristics to a large extent due to aging, regardless of the remaining tread depth.

The age of the tire can be determined based on the production date ⇒ [Tire labeling and tire classifications](#).

WARNING

Old tires can lose pressure suddenly at high speeds or fail and cause accidents and serious injuries. This is true even if the tires have not been used yet.

- Only use tires that are more than six years old if absolutely necessary and drive with extreme caution if doing so.

New tires

- Drive particularly carefully during the first 370 mi (600 km) with new tires because they must be broken in. Tires that have not been broken in yet have reduced gripping abilities and braking efficiency ⇒ .
- Only use tires with the same design and as close to the same construction, size (rolling circumference) and tread pattern as possible on all four wheels.
- The tread depth of new tires may vary between tire models and manufacturers due to different design features and tread designs.

WARNING

New tires must be broken in because they have reduced traction and braking efficiency when they are new.

- To reduce the risk of accidents and serious injuries, drive carefully during the first 370 miles (600 km).

 **The size specifications for new tires may vary significantly from the actual tire dimensions for different tire brands.**

Replacing tires

- At a minimum, replace both tires on a single axle.
- Only replace old tires with tires that have been approved by Volkswagen for your vehicle model.
- Never use tires whose size exceeds the measurement of tires that are approved by Volkswagen ⇒ .

Vehicles with Tire Pressure Monitoring System

- When replacing the factory-installed wheels, make sure the new wheels are equipped with sensors that are compatible with the TPMS ⇒ [Tire Pressure Monitoring System](#).
- You must drive for a little while at a speed above approximately 15 mph (25 km/h) for the new wheels to be detected.

When replacing or reinstalling the sensors, Volkswagen recommends always using a new valve set and seal set.

Additional information about the TPMS ⇒ [Tire Pressure Monitoring System](#).

WARNING

Tires must have enough clearance from vehicle components. If there is not enough clearance, tires could rub against components of the suspension, the body, and the brake lines, which can cause the brake system to fail, the tread to separate, and the tire to fail.

- The actual dimensions of the tires must not exceed the dimensions of the tire manufacturers approved by Volkswagen, and the tires must not rub against other components of the vehicle.

NOTICE

Avoid strong impacts and drive around obstacles where possible. The risk of tire damage is especially great if driving over potholes and curbs. Damage to the tires and rims can result.

NOTICE

Do not damage the valves when replacing tires. Never drive without caps on the valves. The valves could be damaged.

NOTICE

When replacing or modifying the sensors, a new valve set and seal set must always be used.

 Always dispose of old tires correctly and according to regulations.

 **If the spare wheel is different from the regular vehicle wheels, e.g. in the case of winter tires or a temporary spare wheel, only use the spare wheel temporarily and in the event of a breakdown, and drive especially carefully. Replace the compact spare wheel with a regular wheel as soon as possible.**

 **Using tires approved by Volkswagen ensures that the dimensions will fit correctly on your vehicle. If other tires are used, the seller must provide a certificate from the tire manufacturer stating that the tires are suitable for the vehicle. Keep the certificate stored safely in the vehicle.**

Handling rims

Preventing damage to the rims

Missing hubcaps can cause damage to the rims and wheel bolts.

- Missing hubcaps can cause damage to the rims and wheel bolts.
Always install missing hubcaps before driving.
- Always drive over curbs and other low obstacles slowly and at a right-angle so that both front wheels come into contact with the obstacle at the same time.
- Replace missing dust caps on the valves immediately.
- Check the tire pressure regularly.

Rims with bolted rim ring or accent elements

Rims with a bolted rim ring or accent element consist of multiple pieces. These pieces are connected together with special bolts. Damaged rims must be replaced and may only be repaired by an authorized Volkswagen dealer or authorized Volkswagen Service Facility. Volkswagen recommends contacting an authorized Volkswagen dealer or authorized Volkswagen Service Facility.

Rim identification

In some countries, new rims must include information about certain properties. The following information may be on the rim:

- Seal of conformity
- Rim size
- Manufacturer or brand name
- Production date (month/year)
- Country of origin
- Serial number

- Raw material batch number
- Commodity code

⚠ WARNING

Using unsuitable or damaged rims can impair driving safety and cause accidents and serious injuries.

- Only use rims permitted for the vehicle.
- Check the rims regularly for damage and replace them if necessary.

⚠ WARNING

Loosening and tightening bolts incorrectly on rims with bolted rim rings can cause accidents and serious injuries.

- Never loosen the bolts on rims with a bolted rim ring.
- Have all procedures on rims with bolted rim rings performed by an authorized Volkswagen dealer or authorized Volkswagen Service Facility. Volkswagen recommends contacting an authorized Volkswagen dealer or authorized Volkswagen Service Facility.

Maintaining wheels and tires

Tire pressure

Checking the tire pressure

- Check the tire pressure at least once a month.
- Check the tire pressure only when tires are cold. The specified tire pressure only applies to a cold tire. The tire pressure on warm tires is higher than on cold tires. Therefore, never release air from a warm tire to adjust the tire pressure.
- Always adjust the tire pressures to the vehicle load ⇒ ⚠.
- After adjusting tire pressures, always screw the caps on the valves and note the information about the Tire Pressure Monitoring System (TPMS).
- Always use the tire pressures specified on the label. Never exceed the maximum tire pressure specified on the side of the tire.

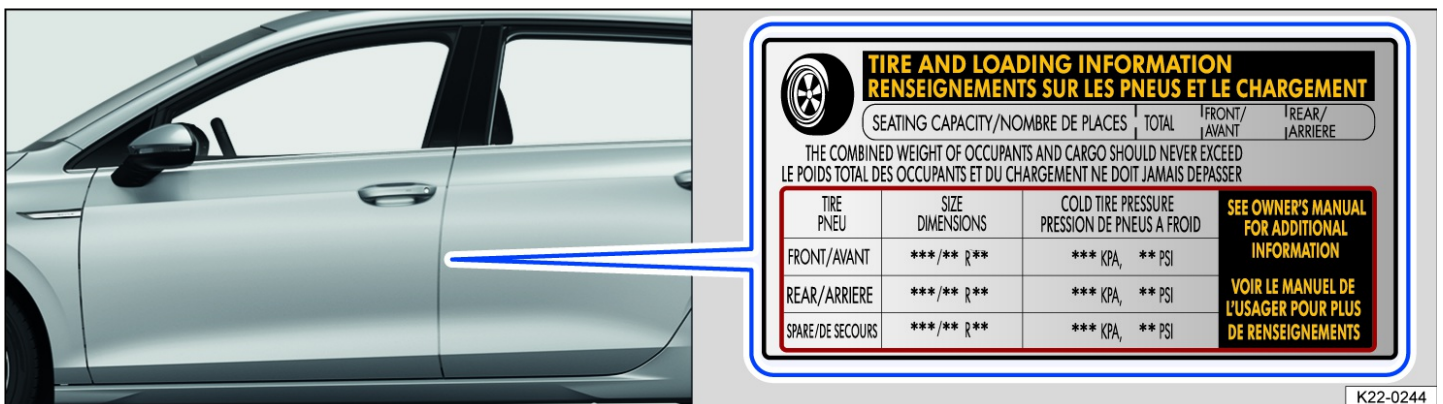

Fig. 179 On the driver door pillar: Tire inflation pressure label.

The correct tire pressure for the tires fitted at the factory can be found on a label on the B-pillar of the driver door *fig. 179*. The factory-installed tires can be winter, summer or all-season tires.

An incorrect tire pressure can cause increased tire wear, negatively affect driving behavior and damage tires. Compliance with the correct tire pressure is very important, particularly when driving at high speeds.

The specified tire pressure is given for a cold tire. For warm tires, the pressure is higher.

Never reduce the pressure of a warm tire in order to reach the specified value. This will cause the actual pressure when the tire is cold to be too low.

⚠ WARNING

Incorrect tire pressures can cause tires to suddenly lose air or go flat while driving. This can cause accidents and fatal injuries.

- If the tire pressure is too low, the tire can heat up so much while driving that the tread separates or the tire ruptures.
- Excessive speeds and vehicle loads can cause overheating, sudden tire damage (including tire blow-outs), and separation of the tread, which can then result in loss of vehicle control.
- An incorrect tire pressure shortens the service life of the tire and negatively affects driving behavior.
- Check the tire pressures regularly, at least once a month and also before driving long distances.
- All tires must always be inflated to the correct pressure based on the load.

- Never reduce the tire pressure when tires are warm.

NOTICE

- When positioning the tire pressure gauge, make sure it is not tilted at the valve stem. If it is, it could damage the tire valve.
- Always make sure all valve caps are fully tightened when driving.

 Tire pressures that are too low increase fuel consumption.

Tire inflation pressure for cold tires

Model	Size designation	Tire pressure		
		psi	kPA	bar
Arteon front wheel drive	245/45 R18 96H	32	220	2.2
	245/40 R19 94H	35	240	2.4
	245/35 R20 95H xl	38	260	2.6
Arteon all-wheel drive (4MOTION)	245/45 R18 96H	35	240	2.4
	245/40 R19 94H	38	260	2.6
	245/35 R20 95H xl	42	290	2.9
Compact spare wheel	T125/70 R18	60	420	4.2

Details of the correct tire pressure are located on the tire pressure label on the driver's door pillar. If the details on the tire pressure label differ from the details in the Manual, the details on the tire pressure label apply.

Monitoring the tightening torque

The correct wheel bolts must always be used for each vehicle model, and these bolts must always be tightened to the correct torque. The wheel bolt tightening torque must be checked regularly with a functional torque wrench. In addition, the tightening torque must be checked immediately after each wheel change with a functional torque wrench. If the wheel bolts are not tightened enough to meet the specification, the wheel bolts and rims could come loose while driving. Exceeding the tightening specification could damage the wheel bolts and threads.

Wheel bolts that are corroded and difficult to turn must be replaced and the threads in the wheel hub must be cleaned before checking the tightening torque. Never grease or oil the wheel bolts and the threads in the wheel hub.

Wheel bolt tightening specification

The tightening torque of the wheel bolts is specified in the chapter on replacing wheels → page , *Wheel bolts*.

WARNING

If the wheel bolts are not tightened correctly or are missing, the wheels could become loose and lead to loss of vehicle control, accidents, and serious injuries.

- Never drive with missing or loose wheel bolts.

- Always use wheel bolts that are correct for the rim and the vehicle model.
- Always tighten the wheel bolts to the correct tightening torque. If you do not have a torque wrench, tighten the wheel bolts with the lug wrench and then have the tightening torque checked as soon as possible by an authorized Volkswagen dealer or authorized Volkswagen Service Facility. Volkswagen recommends contacting an authorized Volkswagen dealer or authorized Volkswagen Service Facility.
- Never grease or oil the wheel bolts and the threads in the wheel hub. Even when tightened to the specification, they could become loose while driving.

Replacing tires

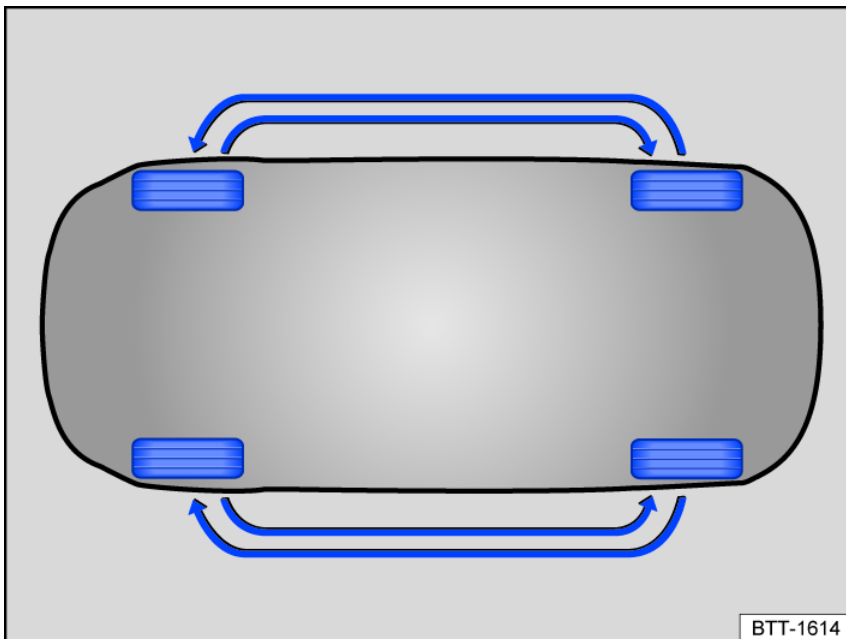

Fig. 180 General example: Diagram for rotating the wheels.

To ensure that the tires wear evenly, rotating the tires regularly according to the diagram is recommended [fig. 180](#). This will allow the tires to have approximately the same length of service life.

Volkswagen recommends having the wheel replacement carried out by an authorized Volkswagen dealer or authorized Volkswagen Service Facility. Volkswagen recommends contacting an authorized Volkswagen dealer or authorized Volkswagen Service Facility.

Monitoring the tread depth

Tread depth

Most driving situations require a tire tread that is as deep as possible. All tires, or at least tires on the same axle, must have an even tread depth ⇒ ⚠. This applies in particular to wet or wintry road conditions.

In most countries, the legal minimum tread depth is 1/16 of an inch (1.6 mm). This is measured in the tread grooves next to the wear indicators. Observe any other legal regulations in force in the country in which you are driving.

Note the legal requirements in the applicable country for minimum tread depths on winter tires and all-season tires.

Tire wear

Tire wear depends on various factors:

- Driving style.
- Wheel balancing.
- Running gear alignment.

Driving quickly around curves, rapid acceleration, and heavy braking increase tire wear.

An imbalance can occur while driving, which can be noticed by uneven steering. Tire imbalances also affect tire wear. In these situations, have the wheels balanced again.

Incorrect wheel alignment impairs driving safety and increases tire wear. If there is a high degree of tire wear, have the wheel alignment checked by an authorized Volkswagen dealer or authorized Volkswagen Service Facility. Volkswagen recommends contacting an authorized Volkswagen dealer or authorized Volkswagen Service Facility.

Tread wear indicator in tires



Fig. 181 Tire tread: tread wear indicator.

The tread wear indicator indicates if a tire is worn out. At the latest, the tire must be replaced if the tread depth is worn down to the tread wear indicator.

The tread wear indicator is 1.6 mm (1/16 in) above the base of the tread *fig. 181*. Markings on the sides of the tire indicate the location of the tread wear indicator *fig. 181*.

⚠ WARNING

Worn tires are a safety risk and can cause the driver to lose control of the vehicle and lead to serious injuries.

- You must replace tires with new tires at the latest when the tires are worn down to the wear indicator.
- Worn tires have significantly less grip, especially on wet roads, and the vehicle is more likely to “hydroplane”.
- Worn tires reduce the driver’s ability to control the vehicle well in normal and difficult driving situations, and they increase the braking distance as well as the risk of skidding.

Wheels and tires in snow and ice

Winter tires

Summer tires offer very little holding force on icy or snowy roads. Winter or all-season tires improve vehicle handling and braking performance in winter road conditions. Volkswagen recommends using winter tires on the vehicle at temperatures below +45 °F (+7 °C) or in winter road conditions. This also applies to vehicles with all-wheel drive (4MOTION).

The effectiveness of winter or all-season tires is greatly reduced when the tire tread is worn down to a depth of 3/16 in (4 mm).

The following applies when using winter tires:

- Follow all applicable laws in the country of operation.
- Use winter tires on all four wheels at the same time.
- Only use in winter road conditions.
- Only use the tire sizes permitted for the vehicle.
- Only use winter tires that have the same belt construction, size, and tread pattern.
- Follow the speed restriction based on the speed rating ⇒ ⚠.

Speed restriction

Winter tires have a speed restriction based on their speed rating ⇒ *Tire labeling and tire classifications*.

A speed warning can be set in the Vehicle settings menu in the Infotainment System under the Tires menu.

On V winter tires, the speed restriction and required tire pressure depend on the engine. Always ask an authorized Volkswagen dealer or authorized Volkswagen Service Facility about the permitted speed and required tire pressure. Volkswagen recommends contacting an authorized Volkswagen dealer or authorized Volkswagen Service Facility.

⚠ WARNING

Do not be tempted into taking safety risks due to the improved vehicle handling that the winter tires provide in winter conditions.

Exceeding the speed limit for the winter tires may lead to sudden tire failure and loss of vehicle control.

- Never ignore the speed limit for the winter tires fitted to your vehicle, even if the permissible maximum speed for the vehicle is higher.
- Never exceed the maximum load for the winter tires fitted to your vehicle.

- Adapt your speed and driving style to the visibility, weather, road and traffic conditions.

 When temperatures are above +45 °F (+7 °C), summer tires provide better vehicle handling. There is less road noise, the tires wear more slowly, and economy is better.

 Winter tires fitted to vehicles with a Tire Pressure Monitoring System must have sensors that are compatible with the Tire Pressure Monitoring System to ensure that the system functions correctly ⇒ [Troubleshooting the Tire Pressure Monitoring System](#). If the dimensions of the winter tires do not match the dimensions of the summer tires and require a different cold tire pressure, you will need to adapt the tire pressures for the Tire Pressure Monitoring System ⇒ [Tire Pressure Monitoring System](#).

 You can contact an authorized Volkswagen dealer or authorized Volkswagen Service Facility for permitted winter tire sizes. Volkswagen recommends contacting an authorized Volkswagen dealer or authorized Volkswagen Service Facility.

Snow chains

Note the legal requirements and the permitted maximum speed when driving with snow chains.

Snow chains improve driving and braking handling when on roads covered with ice or snow.

Snow chains may only be mounted on the front wheels and only on the following tire/rim combinations:

Tire size	Rim
215/55 R 17	7 J x 17 ET 3 8

If possible, use fine-mesh snow chains that include a chain lock no larger than 13.5 mm (17/32 in).

Volkswagen recommends contacting an authorized Volkswagen dealer or authorized Volkswagen Service Facility for more information about wheel, tire, and snow chain sizes. Volkswagen recommends contacting an authorized Volkswagen dealer or authorized Volkswagen Service Facility.

Snow chains may only be used on tire and rim combinations that are approved for snow chain operation.

If using snow chains, remove the wheel covers and rim accent rings before mounting the snow chains. However, the wheel bolts must be covered with caps for safety reasons. Caps can be obtained from an authorized Volkswagen dealer or authorized Volkswagen Service Facility. Volkswagen recommends contacting an authorized Volkswagen dealer or authorized Volkswagen Service Facility.

Using snow chains on the compact spare tire or collapsible spare tire

Using snow chains on the compact spare tire or collapsible spare tire is not permitted for technical reasons.

1. If a front tire is flat, mount the compact spare tire or collapsible spare tire on the rear axle.
2. Replace the damaged front wheel with the removed rear wheel. Pay attention to the running direction when doing this.

Volkswagen recommends attaching the snow chains before mounting the wheel.

WARNING

Using unsuitable snow chains or installing snow chains incorrectly can cause accidents and serious injuries.

- Always use the correct snow chains.
- Follow the installation instructions provided by the snow chain manufacturer.
- Never drive faster than permitted when snow chains are mounted.

NOTICE

- Remove snow chains when driving on roads without snow. Otherwise, snow chains can impair handling and damage the tires, and the chains will quickly be destroyed.
- Snow chains that come into contact with the rim directly can scratch or damage the rim. Volkswagen recommends using snow chains with integrated rim protection.

²⁾ Not for vehicles with adaptive chassis control (DCC) ⇒  [Introduction](#).

Troubleshooting

Damage to tires and rims can often occur where it is not visible ⇒ .

If you suspect that a wheel is damaged, slow down and stop as soon as traffic allows and it is safe to do so.

Vehicle pulls to one side or unusual vibrations

The vehicle pulls to the left or right when driving, or there are unusual vibrations. This could indicate tire damage or too low a tire inflation pressure.

 Check the tires!

Slow down immediately and stop the vehicle as soon as the traffic situation allows and it is safe to do so.

1. Check the tires and rims for damage.
2. Do not continue driving if there is tire damage.
3. Replace the damaged wheel →  [Introduction](#). If necessary, contact an authorized Volkswagen dealer or authorized Volkswagen Service Facility for assistance.
4. If no exterior damage is visible, drive slowly and carefully to the nearest authorized Volkswagen dealer or authorized Volkswagen Service Facility to have the vehicle checked. Volkswagen recommends contacting an authorized Volkswagen dealer or authorized Volkswagen Service Facility.

Foreign object stuck in the tire

A foreign object is stuck in the tire or between the tread segments.

On vehicles with run-flat tires (AirStop® tires): leave the object in the tire and contact an authorized Volkswagen dealer or authorized Volkswagen Service Facility. Volkswagen recommends contacting an authorized Volkswagen dealer or authorized Volkswagen Service Facility. Sealant that has been applied to the inside of the tire running surface will surround the object and seal the tire temporarily.

1. If an object has punctured through to the inside of a tire, leave the object in place. Objects stuck between the tire tread segments can be removed.
2. Replace the damaged wheel →  [Introduction](#). If necessary, contact an authorized Volkswagen dealer or authorized Volkswagen Service Facility for assistance.
3. Check and adjust the tire pressure.
4. Contact an authorized Volkswagen dealer or authorized Volkswagen Service Facility. Volkswagen recommends contacting an authorized Volkswagen dealer or authorized Volkswagen Service Facility.

Tires lose traction

The vehicle loses traction when driving along curved stretches, and swerves. The braking distance is longer and the anti-slip regulation (ASR) and the anti-lock brake system (ABS) take control earlier.

The tire may be too worn down to guarantee sufficient traction → [Monitoring the tread depth](#).

1. Go slowly and carefully to the nearest suitably qualified professional to have the vehicle checked. Volkswagen recommends contacting an authorized Volkswagen dealer or authorized Volkswagen Service Facility.

Wheel bolts can only be undone with difficulty

Wheel bolts can corrode over time. This may mean that the wheel bolts can only be undone with difficulty.

1. Contact professional assistance, or drive slowly and carefully to the nearest qualified professional to have the vehicle checked. Volkswagen recommends contacting an authorized Volkswagen dealer or authorized Volkswagen Service Facility.

WARNING

Unusual vibrations or the vehicle pulling to one side while driving may indicate tire damage.

- Slow down immediately and stop the vehicle as soon as the traffic situation allows and it is safe to do so.
- Check the tires and rims for damage.
- Never continue driving with damaged tires or rims. Instead, seek professional assistance.
- If no exterior damage is visible, drive slowly and carefully to the nearest authorized Volkswagen dealer or authorized Volkswagen Service Facility to have the vehicle checked. Volkswagen recommends contacting an authorized Volkswagen dealer or authorized Volkswagen Service Facility.

Tire Pressure Monitoring Systems

Introduction

The Tire Pressure Monitoring System (TPMS) warns the driver if tire pressures are too low.

The following Tire Pressure Monitoring Systems (TPMS) are available for this vehicle:

Tire Pressure Monitoring System

- Monitors tire pressures using pressure sensors on every tire valve (direct measurements). The tire valves are made of metal.

The reference pressure for the Tire Pressure Monitoring System is the recommended tire pressure for the tires installed at the factory when the tires are cold at maximum load. The reference pressure corresponds to the details on the tire pressure label → [Tire pressure](#).

The Tire Pressure Monitoring System (⚠) may not react at first or may not react at all when you are driving in a sporty manner, or on snow-covered or unpaved roads, when you are driving with snow chains, or in certain other situations. A change in the tread circumference of a tire is signaled by the Tire Pressure Monitoring System indicator in the instrument cluster (telltale).

The tire pressure recommended for the tires originally installed on the vehicle is on a sticker on the driver door jamb.

Each tire, including the spare (if provided), should be checked monthly when cold and inflated to the inflation pressure recommended by the vehicle manufacturer on the vehicle placard or tire inflation pressure label. (If your vehicle has tires of a different size than the size indicated on the vehicle placard or tire inflation pressure label, you should determine the proper tire inflation pressure for those tires).

As an added safety feature, your vehicle has been equipped with a tire pressure monitoring system (TPMS) that illuminates a low tire pressure telltale when one or more of your tires is significantly under-inflated. Accordingly, when the low tire pressure telltale illuminates, you should stop and check your tires as soon as possible, and inflate them to the proper pressure. Driving on a significantly under-inflated tire causes the tire to overheat and can lead to tire failure. Under-inflation also reduces fuel efficiency and tire tread life, and may affect the vehicle's handling and stopping ability.

Please note that the TPMS is not a substitute for proper tire maintenance, and it is the driver's responsibility to maintain correct tire pressure, even if under-inflation has not reached the level to trigger illumination of the TPMS low tire pressure telltale.

Your vehicle has also been equipped with a TPMS malfunction indicator to indicate when the system is not operating properly. The TPMS malfunction indicator is combined with the low tire pressure telltale. When the system detects a malfunction, the telltale will flash for approximately one minute and then remain continuously illuminated. This sequence will continue upon subsequent vehicle start-ups as long as the malfunction exists.

When the malfunction indicator is illuminated, the system may not be able to detect or signal low tire pressure as intended. TPMS malfunctions may occur for a variety of reasons, including the installation of replacement or alternate tires or wheels on the vehicle that prevent the TPMS from functioning properly. Always check the TPMS malfunction telltale after replacing one or more tires or wheels on your vehicle to ensure that the replacement or alternate tires and wheels allow the TPMS to continue to function properly.

WARNING

The intelligent technology of the Tire Pressure Monitoring System (TPMS) cannot overcome the natural laws of physics and it can only operate within the limits of the system. Handling wheels and tires incorrectly can result in a sudden loss of tire pressure, tread separation, and ruptured tires.

- Check the tire pressure regularly and always maintain the specified values ⇒ [Tire pressure](#). If the tire pressure is too low, the tire can heat up so much that the tread separates or the tire ruptures.
- Always inflate the tires to the correct tire pressure when the tires are cold according to the tire inflation pressure label ⇒ [Tire pressure](#).
- Check the tire pressure regularly when the tires are cold. If necessary, adjust the tire pressure when the tires are cold so that it is suitable for the tires installed on your vehicle ⇒ [Tire pressure](#).
- Check the tires regularly for signs of wear or damage.
- Never exceed the maximum permissible speed and tire load specified for the tires fitted to your vehicle.

WARNING

Different tire pressures or low tire pressure can cause tire damage, tire failure, loss of vehicle control, crashes, serious injuries, and death.

- If the (⚠) warning light turns on, stop the vehicle immediately and check all of the tires ⇒ [Troubleshooting](#).
- Different tire pressures or low tire pressure can increase tire wear, decrease vehicle stability, and increase braking distance.
- The driver is responsible for maintaining the correct tire pressure in all tires on the vehicle. The recommended tire pressure can be found on a label ⇒ [Tire pressure](#).
- The Tire Pressure Monitoring System (TPMS) can only function correctly when all tires are inflated to the correct pressure when they are cold.
- All tires must always be inflated to the correct pressure based on the load ⇒ [Tire pressure](#).
- Inflate all tires to the correct tire pressure before every drive ⇒ [Tire pressure](#).
- When the tire pressure is too low, the tire must flex more when driving. This could cause the tire to become so hot that the tread could separate, the tire could rupture, and you could lose control of the vehicle.
- Driving at high speeds and excessive vehicle load can cause a tire to become so hot that the tire could rupture and you could lose control of the vehicle.
- Tire pressure that is too high or too low shortens the service life of the tire and affects driving behavior.
- If the tire is not "flat" and the tire does not need to be replaced immediately, drive slowly to the nearest authorized Volkswagen dealer or authorized Volkswagen Service Facility to have the tire pressure checked and corrected ⇒ [Troubleshooting](#). Volkswagen recommends contacting an authorized Volkswagen dealer or authorized Volkswagen Service Facility.

 Low tire pressure increases fuel consumption and tire wear.

 New tires may expand slightly the first time they are driven at high speeds, which can trigger a tire pressure warning.

 Only replace old tires with tires that have been approved by Volkswagen for the vehicle model.

 Do not rely on the Tire Pressure Monitoring System alone. Inspect the tires regularly to make sure the tire pressure is correct and check the tires for any signs of damage, such as punctures. Remove any objects stuck in the tire tread as long as they have not punctured the inside of the tire.

Tire Pressure Monitoring System

 Please read the introductory information and heed the Warnings and Notice  [Introduction](#).

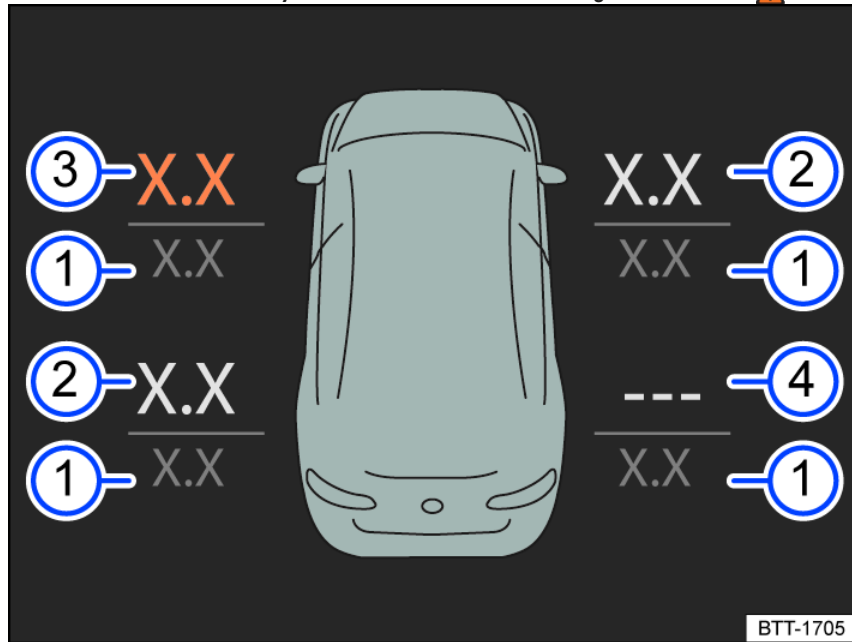



Fig. 182 Diagram of the instrument cluster display: current tire pressures.

- ① Specified pressure in psi.
- ② Actual pressure in psi.
- ③ Loss of pressure in the left front tire.
- ④ System malfunction in the right rear tire.

Function description

The Tire Pressure Monitoring System (TPMS) monitors tire pressure in the four tires while driving using pressure sensors installed on the tires. The system warns the driver if there is a loss of pressure.

Tire pressure display in the instrument cluster

1. Open the Vehicle status menu in the instrument cluster display  [Vehicle settings menu](#).

The vehicle is shown with the actual and specified pressures for all tires [fig. 182](#).

When the ignition is switched on, the display initially shows the tire pressures that were last read by the system. When you begin driving, the display will update. If there is low tire pressure, the actual values and the affected tires will be marked in the display [fig. 182](#).

The sensors do not send any tire pressures when the tires are not moving. This helps to conserve the sensor batteries.

If no tire pressures are sent, the last tire pressures received will be shown in grey.

Switching the tire pressure monitoring system on or off (depending on the vehicle)

Follow the local applicable legal regulations regarding the tire pressure monitoring system.

If a tire set that does not contain tire pressure sensors or whose tire pressure sensors are not compatible with the vehicle is installed, the  indicator light will bli for about one minute and then stay on. The tire pressures will not be monitored. It is not possible to switch the system off.

Adapting tire pressures

The tire pressure must be checked and adapted each time the vehicle load changes. The tire pressure that is recommended for the vehicle is located on a label on the driver's door pillar or on the inside of the fuel filler flap.

The values read by the pressure gauge when inflating the tire may differ from the values detected by the TPMS. The TPMS is more accurate!

Selecting tire type

When changing to a tire in a different size, it may be necessary to adapt the specified pressure of the Tire Pressure Monitoring System to the new tires. Contact an authorized Volkswagen dealer or authorized Volkswagen Service Facility to do so. Volkswagen recommends contacting an authorized Volkswagen dealer or authorized Volkswagen Service Facility.

If tires in a size that was not intended at the factory are installed, the specified pressure for these tires can be set by an authorized Volkswagen dealer or authorized Volkswagen Service Facility. Volkswagen recommends contacting an authorized Volkswagen dealer or authorized Volkswagen Service Facility.

Spare wheel, compact spare wheel, or collapsible spare wheel

The pressure of the spare wheel, compact spare wheel, or collapsible spare wheel in the vehicle trunk is not monitored.

NOTICE

- The pressure sensors are installed on special aluminum valves that are fixed in place. When filling and checking the tire pressure, do not bend the valves “into position”.
- The valves and sensors can be damaged if valve caps are missing. For this reason, always make sure all valve caps are fully tightened when driving. Do not use metal valve caps.
- Do not use “comfort valve caps”, because these do not form a seal and the sensors could be damaged.

Troubleshooting the Tire Pressure Monitoring System

 Please read the introductory information and heed the Warnings and Notice ⇒  *Introduction.*

Tire pressure low

The yellow indicator light turns on.

Message: Flat tire! The pressure of one or more tires is below 20 psi (1,4 bar/140 kPa) or there is a critical loss of tire pressure.

1.  **Do not continue driving!**
2. Check all tires for external damage and objects embedded in them.
3. Check the pressure in all tires ⇒ *Tire pressure.*
4. Change the tire or drive slowly to the nearest authorized Volkswagen dealer or authorized Volkswagen Service Facility. Volkswagen recommends contacting an authorized Volkswagen dealer or authorized Volkswagen Service Facility.

Message: Tire pressures are too low. This warning indicates a critical loss of pressure in at least one tire.

1. Check and adjust the pressure in all the tires ⇒ *Tire pressure.*
2. Change the tire or drive slowly to the nearest authorized Volkswagen dealer or authorized Volkswagen Service Facility. Volkswagen recommends contacting an authorized Volkswagen dealer or authorized Volkswagen Service Facility.

Message: Please check the tire pressures. The warning indicates a minor loss of pressure in at least one tire.

1. Avoid driving long distances and at high speeds when the message is displayed.
2. Check and adjust the tire pressure in all tires ⇒ *Tire pressure.*

Tire pressure monitoring system malfunction

The yellow indicator light flashes for approximately one minute and then stays on.

One or more tires with tire pressure monitoring sensors were installed but not detected.

1. Drive for a few minutes until the indicator light turns off.

One or more tires without tire pressure monitoring sensors were installed or a tire pressure monitoring sensor is malfunctioning.

1. Install tires with functioning tire pressure monitoring sensors.

There is a system malfunction.

1. Switch the ignition off and back on again. If the malfunction persists, contact a suitably qualified professional. Volkswagen recommends contacting an authorized Volkswagen dealer or authorized Volkswagen Service Facility.

There is a malfunction between a sensor and the system. Because of overlap among sensors that function in the same frequency range, the system function may be temporarily impaired.

1. Switch off or avoid using sources of interference, such as mobile devices, remote controls, or children's toys.

Wheel covers

Hubcap

Vehicles with removable wheel center trim



Fig. 183 Remove the hubcap.

The wheel center trim is for protecting the wheel bolts and must be reattached after a wheel change.

1. *Removing:* Take the extraction hook out of the vehicle toolkit ⇒ *Vehicle tool kit components* and insert in a hole (alloy wheel) or hook it to the edge (steel wheel) of the hubcap *fig. 183*.
2. Remove the trim in the direction of the arrow *fig. 183*.
3. *Installing:* press the hubcap centrally on the rim and press it against the rim until you feel it engage.

⚠ WARNING

Unsuitable wheel covers and assembling wheel covers incorrectly can cause accidents and serious injuries.

Wheel covers that are installed incorrectly can loosen while driving and endanger other road users.

- Do not use damaged hubcaps.
- Always make sure that the air supply to cool the brakes is not blocked or reduced. This also applies when wheel covers are retrofitted. An insufficient air supply can cause the braking distance to increase significantly.

Wheel covers

Removing the wheel hub cover



Fig. 184 Remove the wheel hub cover.

The full wheel covers protect the wheel bolts and must be reattached after a wheel change.

1. Take the extraction hook out of the vehicle tool kit ⇒ *Vehicle tool kit components*.
2. Engage the extraction hook in one of the openings on the wheel hub cover.
3. Remove the wheel hub cover with extraction hook in the direction of the arrow. If necessary, use a lug wrench for removal *fig. 184*.

Installing the full wheel cover

1. Make sure the anti-theft wheel bolts are positioned correctly ⇒ *Wheel bolts*.
2. Press the full wheel cover onto the rim so that the opening for the valve aligns with the tire valve. Make sure that the entire outer edge of the cover is secured.

⚠ WARNING

Unsuitable wheel covers and assembling wheel covers incorrectly can cause accidents and serious injuries.

Wheel covers that are installed incorrectly can loosen while driving and endanger other road users.

- Do not use damaged hubcaps.
- Always make sure that the air supply to cool the brakes is not blocked or reduced. This also applies when wheel covers are retrofitted. An insufficient air supply can cause the braking distance to increase significantly.

ⓘ NOTICE

The wheel cover may be screwed tightly and must not be removed with force.

Wheel bolt caps



Fig. 185 Remove the caps from the wheel bolts.

The caps are for protecting the wheel bolts and must be completely reattached after a wheel change.

Removing and attaching caps

1. *Removing:* Take the extraction hook out of the vehicle tool kit ⇒ *Vehicle tool kit components*.
2. Insert the extraction hook through the opening in the cap *fig. 185* and pull in the direction of the arrow.
3. *Attaching:* push the cap all the way on the wheel bolts.

The anti-theft wheel bolt has a separate cap. This cap only fits on the anti-theft wheel bolt and not on conventional wheel bolts.

Wheel change

📖 Introduction

Only change the wheel yourself if the vehicle is parked securely, you are familiar with the safety precautions and the necessary procedures and you have the necessary tools. Some vehicles are delivered from the factory without a vehicle jack and lug wrench. In such cases, have the wheel changed by an authorized Volkswagen dealer or authorized Volkswagen Service Facility. Volkswagen recommends contacting an authorized Volkswagen dealer or authorized Volkswagen Service Facility.

The vehicle jack supplied by the factory is only designed for changing one wheel that has a damaged tire and must be replaced. If both tires on one side of the vehicle, both tires on one axle, or all tires are damaged, contact an authorized Volkswagen dealer or authorized Volkswagen Service Facility for assistance.

WARNING

Changing a wheel can be dangerous, especially when done on the side of the road. To reduce the risk of serious injuries, observe the following:

- Stop the vehicle as soon as it is safe to do so. Park the vehicle a safe distance away from moving traffic to change the wheel.
- All passengers, especially children, must keep a safe distance and be outside of the work area when changing a wheel.
- Switch on the emergency flashers to warn other road users.
- Make sure the vehicle is on level and solid ground. If necessary, place a large, stable surface under the jack.
- Only carry out the wheel change yourself if you are familiar with the necessary steps. Instead, seek assistance from an authorized Volkswagen dealer or authorized Volkswagen Service Facility. Volkswagen recommends contacting an authorized Volkswagen dealer or authorized Volkswagen Service Facility.
- Only use suitable and undamaged tools for wheel changes.
- Always switch off the engine and move the selector lever to the **P** position to reduce the risk of the vehicle moving unintentionally.
- Set the electronic parking brake.
- After changing a wheel, immediately check the tightening torque of the wheel bolts with an undamaged torque wrench that is functioning correctly.

Preparations for changing a wheel

 Please read the introductory information and heed the Warnings and Notice ⇒  [Introduction](#).

Checklist

Always perform the following steps in the specified order to prepare for a wheel change ⇒ :

1. If the vehicle has a flat tire, park the vehicle a safe distance away from moving traffic on level and solid ground as soon as possible.
2. Set the electronic parking brake.
3. Automatic transmission: move the selector lever into the **P** position.
4. Stop the engine and switch the ignition off.
5. Have all vehicle occupants exit the vehicle on the side facing away from traffic and move to a safe area.
6. Turn on the emergency flashers and set up the warning triangle ⇒ [Securing yourself and the vehicle](#). Follow any applicable laws.
7. Block the tire that is diagonal from the one you will be changing with a stone, chocks, or another suitable object.
8. In trailer mode: Disconnect the trailer from the towing vehicle and park it ⇒ [Trailer towing](#).
9. If the luggage compartment is full: remove the contents from the luggage compartment.
10. Where applicable, remove the subwoofer ⇒ [Subwoofer](#).
11. Remove the collapsible spare wheel, full-size spare wheel or compact spare wheel and the vehicle tool kit from the luggage compartment.
12. Remove the wheel covers ⇒ [Wheel covers](#).

WARNING

Failing to heed this checklist that is provided for your own safety can cause accidents and serious injuries.

- Always follow the tasks in the checklist.
- Observe the general safety precautions.

Wheel bolts

 Please read the introductory information and heed the Warnings and Notice ⇒  [Introduction](#).

Loosening wheel bolts



Fig. 186 Changing a tire: loosening the wheel bolts.

Use a suitable lug wrench to loosen the wheel bolts.

Only loosen the wheel bolts a few turns while the vehicle is not raised with the vehicle jack.

1. Slide the lug wrench all the way onto the wheel bolt *fig. 186*.
2. Hold the end of the lug wrench and turn the wheel bolt about one turn counterclockwise ⇒ ⚠.

Or: if a wheel bolt cannot be loosened, carefully press on the end of the lug wrench using your foot. Hold onto the vehicle firmly while doing this and make sure you have secure footing.

Loosening anti-theft wheel bolts

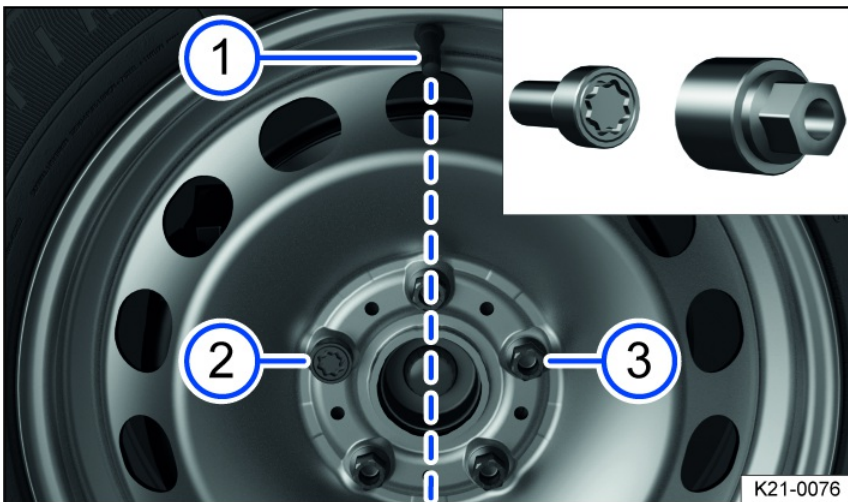

Fig. 187 Changing a tire: tire valve ① and locations of the anti-theft wheel bolt ② or ③.

1. Remove the adapter for anti-theft wheel bolts from the vehicle tool kit.
2. Slide the adapter all the way into the anti-theft wheel bolt.
3. Slide the lug wrench all the way onto the adapter.
4. Hold the end of the lug wrench and turn the wheel bolt about one turn counterclockwise ⇒ ⚠.

Installing anti-theft wheel bolts (full wheel covers)

On wheels with full wheel covers, the anti-theft wheel bolt must be fitted in position *fig. 187* ② or ③, based on the position of the tire valve ①. Otherwise, it will not be possible to install the full wheel cover.

Wheel bolt tightening specification

Tightening specification for wheel bolts in steel and aluminum alloy rims:

- 103 ft-lbs (140 Nm).

Wheel bolts that are corroded and difficult to turn must be replaced and the threads in the wheel hub must be cleaned before checking the tightening torque.

Never grease or oil the wheel bolts and the threads in the wheel hub.

Check the tightening torque using a functioning torque wrench immediately after changing a wheel.

⚠ WARNING

Wheel bolts that are tightened incorrectly can loosen while driving and cause accidents, serious injuries, and loss of vehicle control.

- The wheel bolts and threads in the wheel hub must be clean, easy to move, and free of oil and grease.
- Always use only the lug wrench to loosen and secure the wheel bolts that have been attached to the vehicle at the factory.
- Only loosen the wheel bolts about one turn while the vehicle is not lifted with the jack.
- Never grease or oil the wheel bolts and the threads in the wheel hub. Even when tightened to the specification, they could become loose while driving.
- Never loosen the bolts on rims with a bolted rim ring.
- Check the tightening torque regularly with a torque wrench. If the wheel bolts are not tightened enough to meet the specification, the wheel bolts and rims could come loose while driving. Exceeding the tightening specification could damage the wheel bolts and threads.

⚠ WARNING

Incorrect wheel bolts can loosen while driving and cause accidents, serious injuries, and loss of vehicle control.

- Only use wheel bolts that are intended to be used with the rim.
- Never use different wheel bolts.

Subwoofer

📖 Please read the introductory information and heed the Warnings and Notice ⇒ **⚠ Introduction.**

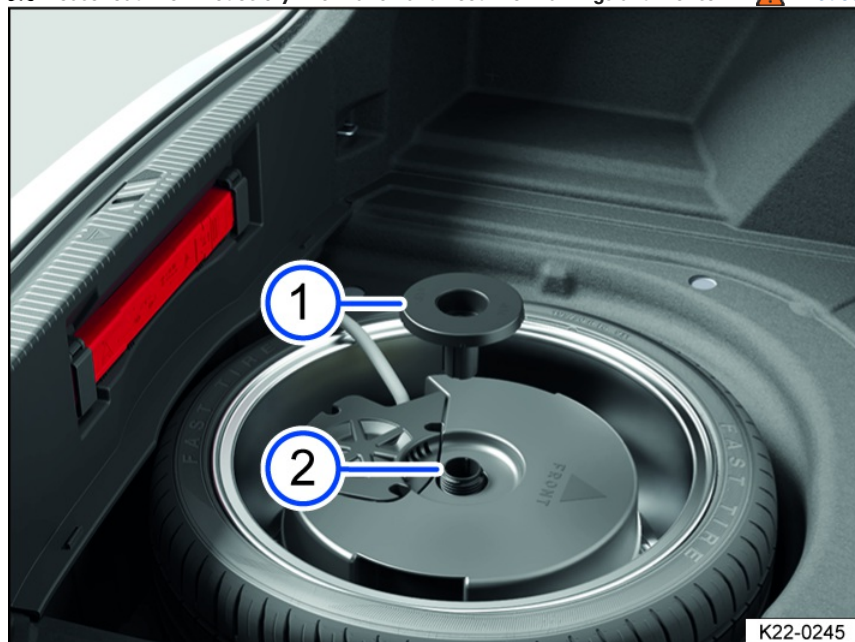

Fig. 188 Removing the subwoofer.



Fig. 189 Leaning the subwoofer.

Before you can remove the spare wheel, you must remove the subwoofer and lean it in the luggage compartment.

Removing the subwoofer

1. Open the trunk lid and hook the floor covering onto the upper edge of the luggage compartment.
2. Depending on the equipment: Pull the spacer [fig. 188](#) up out of the handwheel.
3. Turn the handwheel [fig. 188](#) counterclockwise.
4. Lift the subwoofer out carefully.
5. Lift out the subwoofer and lean it against the side panel of the luggage compartment, ensuring that the subwoofer cannot tip or fall [fig. 189](#).

Installing the subwoofer

1. Place the subwoofer carefully in the rim well. The point of the "FRONT" arrow symbol on the subwoofer must face forward.
2. Turn the handwheel [fig. 188](#) clockwise until the subwoofer is firmly secured.
3. Depending on the equipment: Insert the spacer [fig. 188](#) in the handwheel.
4. Unhook the floor covering and fold it back into place on the luggage compartment floor.

NOTICE

If the subwoofer connector becomes loose or the cable is trapped or kinked, the subwoofer may be damaged.

Spare wheel or compact spare wheel

📖 Please read the introductory information and heed the Warnings and Notice ⇒ ⚠️ [Introduction](#).



Fig. 190 In the luggage compartment: handle to secure the compact spare wheel.

Removing the spare wheel or compact spare wheel

1. Open the trunk lid.
2. Lift up or remove the luggage compartment floor ⇒ *Luggage compartment floor - functions*.
3. If necessary, lift up and remove the carpet.
4. Remove the vehicle tool kit with the container.
5. If necessary, remove the subwoofer ⇒ *Subwoofer*.
6. Remove the locking wedge *fig. 190* ① upward.
7. Turn the handwheel in the center of the spare wheel *fig. 190* ② all the way counterclockwise.
8. Remove the spare wheel or compact spare wheel.

Stowing the removed tire

1. Open the trunk lid.
2. Lift up or remove the luggage compartment floor ⇒ *Luggage compartment floor - functions*.
3. If necessary, lift up and remove the carpet.
4. If the removed wheel fits in the spare wheel well: place the removed wheel with rim down into the spare wheel well so that the center hole on the rim is directly above the hole or the threaded pin.
5. Turn the handwheel clockwise on the threaded pin until the removed wheel is securely fastened.
6. Position the locking wedge *fig. 190* ① in the slot on the threaded pin so that the handwheel cannot turn.
7. Place the vehicle tool kit back in the container and stow it in the luggage compartment.
8. If necessary, place the carpet in the luggage compartment.
9. Reinsert the luggage compartment floor or fold back down ⇒ *Luggage compartment floor - functions*.
10. Close the trunk lid.

If the removed wheel does not fit in the spare wheel well, the wheel must be securely stowed in the luggage compartment on the luggage compartment floor.

If the spare wheel is different from the regular tires

If the spare wheel is different from the regular wheels, then the spare wheel must only be used in the event of a vehicle breakdown and only for a short period of time → .

Note the driver information:

- Do not drive faster than 50 mph (80 km/h).
- Avoid hard acceleration, heavy braking, and fast cornering.
- Do not use snow chains on the compact spare wheel ⇒ *Snow chains*.
- After installing the spare wheel or compact spare wheel, check the tire pressure as soon as possible ⇒ *Tire pressure*.

The tire pressure of the spare wheel, compact temporary spare wheel or temporary spare wheel must be checked every time the tire pressure of the regular wheel is taken, or at least once a month. The tire pressure of the spare wheel, compact spare wheel or temporary spare wheel when the tires are cold must correspond to the details on the tire inflation pressure label ⇒ *Tire pressure*.

WARNING

Incorrect handling of the spare wheel or compact spare wheel can result in loss of vehicle control, collisions, or other accidents, and serious injuries.

- Never use the spare wheel or compact spare wheel if it is damaged or if it is worn down to the wear indicator.
- Some vehicles may be equipped with a compact spare wheel instead of a spare wheel. The compact spare wheel can be identified by a label stating “80 km/h” or “50 mph”. This label indicates the permitted maximum speed at which the tire may be driven. Do not cover the sticker while the wheel is in use.
- Never drive faster than 50 mph (80 km/h).
- Never drive more than 125 miles (200 km) with a temporary compact spare wheel fitted to the drive axle.
- Avoid hard acceleration, hard braking, and driving fast around curves.
- Replace the compact spare wheel as soon as possible with a regular wheel. The spare wheel is only intended for short-term use.
- Always secure the compact spare wheel with the wheel bolts supplied by the factory.
- Never drive with more than one spare wheel that differs from the regular tires.
- After mounting the compact spare wheel, check the tire pressure as soon as possible ⇒ *Tire pressure*.
- Do not use snow chains on the compact spare wheel.

- Never mount a compact spare wheel on the rear axle when in trailer mode ⇒ *Trailer towing*.

Raising the vehicle with the vehicle jack

📖 Please read the introductory information and heed the Warnings and Notice ⇒ ⚠️ *Introduction*.

Open lift points

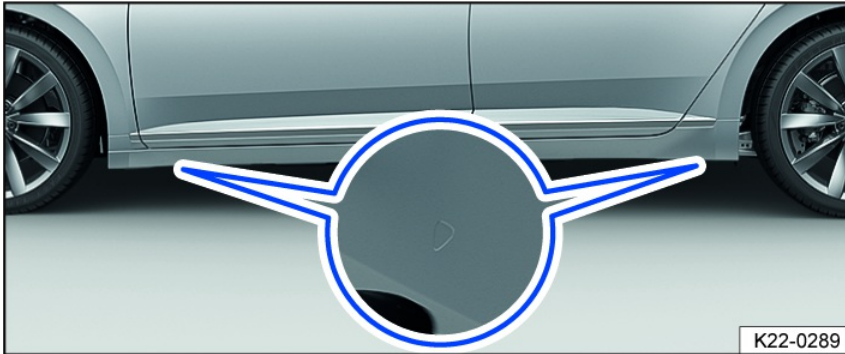

Fig. 191 Open lift points for the vehicle jack.

The vehicle jack must only be positioned at the reinforced areas on the underbody that are located behind the markings on the vehicle body *fig. 191*. The lift point that is nearest the affected tire should be used ⇒ ⚠️.

Covered lift points

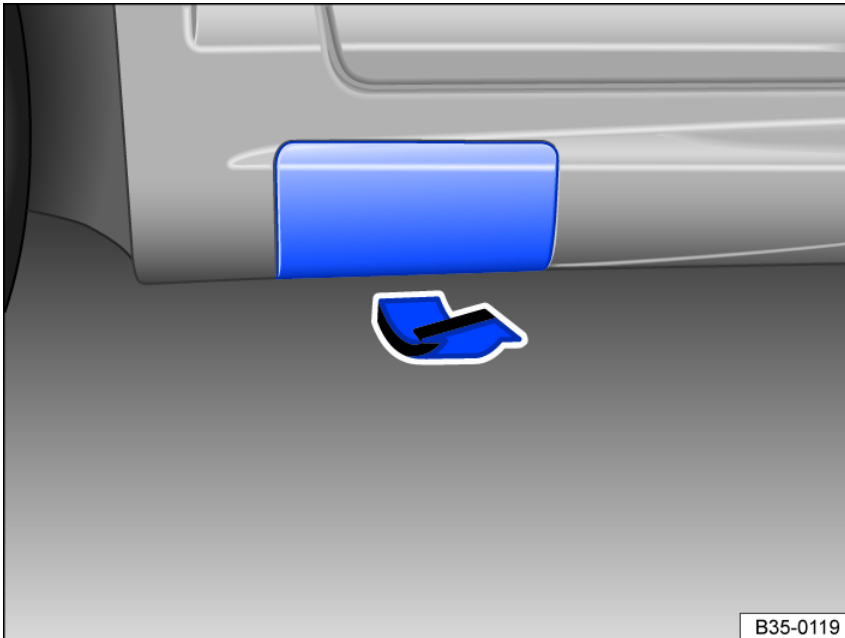
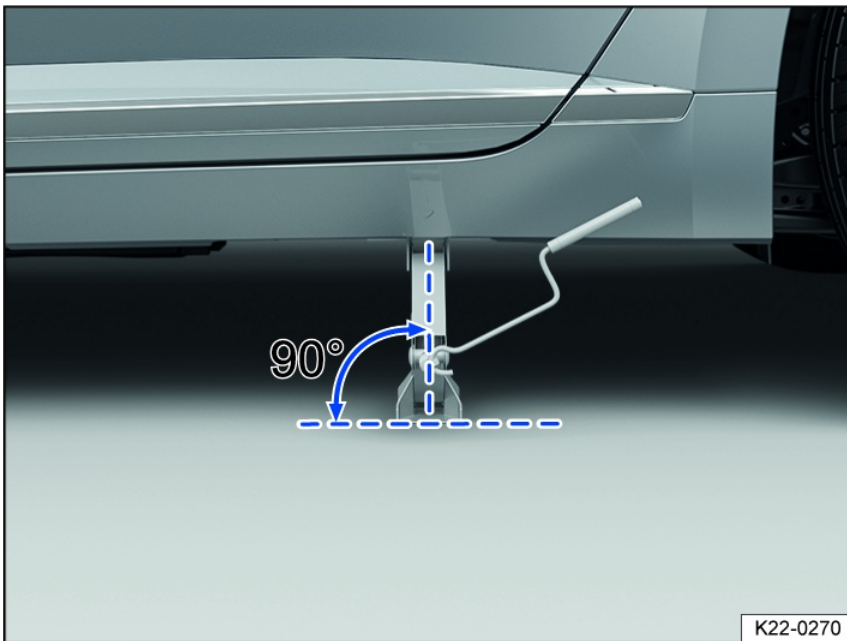

Fig. 192 Fold down cover.

Covered lift points for the vehicle jack depend on the vehicle equipment.

Positioning the vehicle jack with open lift points



K22-0270

Fig. 193 Correct jack setup.

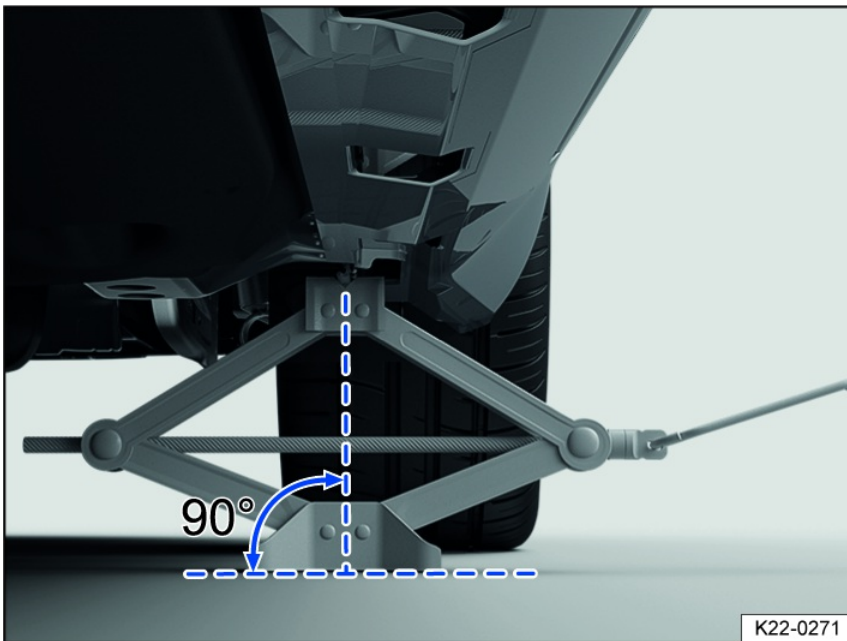

K22-0271

Fig. 194 Jack is positioned on the left side of the vehicle at the rear.

The vehicle jack must only be positioned at the reinforced areas on the underbody that are located behind the markings on the vehicle body *fig. 194*. The lift point that is nearest the affected tire should be used ⇒ ⚠.

Positioning the vehicle jack with covered lift points

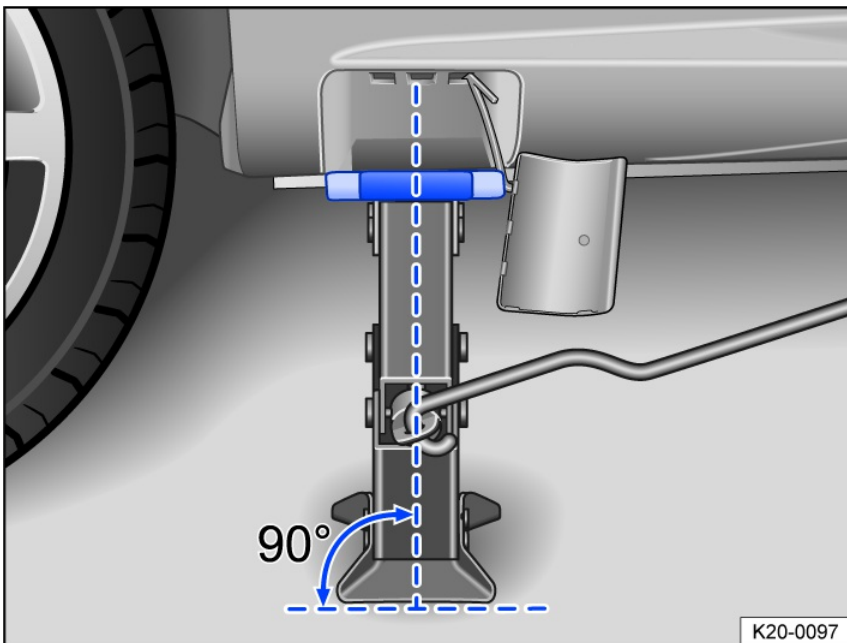

Fig. 195 Correct jack setup.

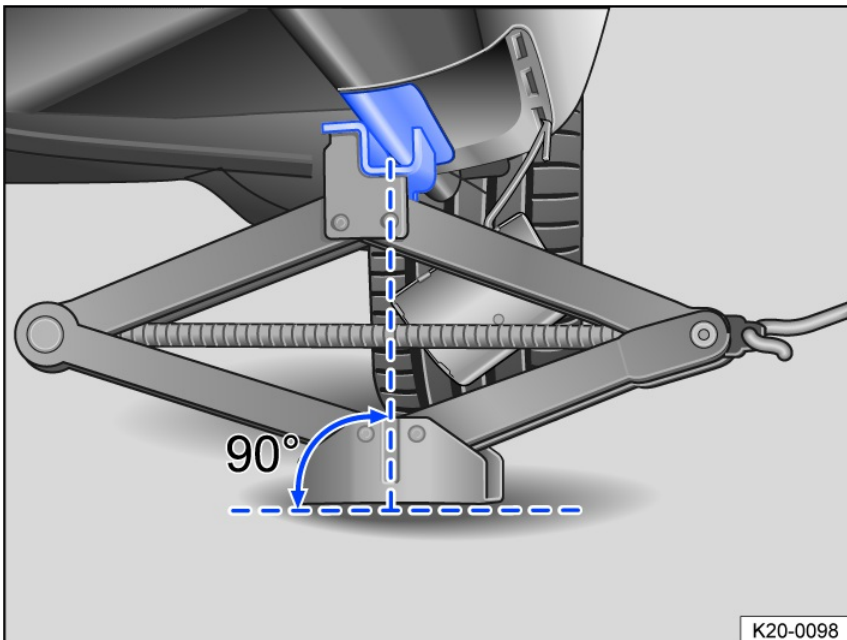



Fig. 196 Jack is positioned on the left side of the vehicle at the rear.

The jack may only be positioned at the lift points shown and only when the cover is folded down *fig. 192*. The lift point that is nearest the affected tire should be used ⇒ ⚠.

Checklist

For your own safety, follow the points below in the order they are given ⇒ ⚠:

1. Select an area where the ground is level and firm for raising the vehicle.
2. Adjust the steering wheel so that the wheels are not pointing straight forward.
3. Stop the engine.
4. Move the selector lever of the automatic transmission into the **P** position.
5. Set the electronic parking brake.
6. Block the tire that is diagonal from the one you will be changing with chocks or other suitable objects.
7. If you are towing a trailer ⇒  *Introduction*: disconnect trailer from the vehicle and park it.
8. Loosen the wheel bolts ⇒ *Wheel bolts*.
9. Position the hand crank in the mount on the jack.
10. Find the vehicle lift point *fig. 191* under the vehicle that is closest to the wheel you will be changing.
11. For covered lift points only: Remove the cover on the side member *fig. 192*: Firmly but carefully pull in the direction of the arrow. The cover has a retaining strap.

12. Crank the jack upward so that it is still positioned under the vehicle lift point.
13. Make sure the entire base of the jack is seated securely on the ground and that the base of the jack is located exactly directly below the lift point [fig. 193](#) and [fig. 194](#) or [fig. 195](#) and [fig. 196](#).
14. Straighten out the vehicle jack and continue raising the bracket on the top of the jack until the bracket is positioned on the brace under the vehicle [fig. 194](#) or [fig. 196](#).
15. Continue raising the vehicle jack until the wheel is lifted off the ground.

⚠ WARNING

Using the vehicle jack incorrectly can result in the vehicle slipping from the jack and causing serious injuries. To reduce the risk of injuries, observe the following:

- Never raise the vehicle if more than one tire is damaged.
- Never raise the vehicle while the engine is running or while the vehicle is on ground that is tilted to the side or sloping.
- Never allow the engine to be started if the vehicle is raised. Engine vibrations could cause the vehicle to fall off the jack.
- Only place the vehicle jack at the lift points described. The bracket on the vehicle jack must firmly grip the sill [fig. 194](#) or [fig. 196](#).
- Only use jacks that are approved by Volkswagen for the vehicle. Other vehicle jacks, including those approved for other Volkswagen models, could slip.
- The ground must be level and firm. Sloped or soft ground can cause the vehicle to slip off the jack. If necessary, place a large, stable surface under the jack.
- If you are on a slippery surface such as tile, place a non-slippery object such as a rubber mat on the ground to prevent the jack from slipping.
- Never place any part of your body such as your arm or leg under the vehicle when it is supported only by the jack.
- If you must work underneath the vehicle, additionally support the vehicle securely with suitable stands.

⚠ WARNING

Failing to heed this checklist that is provided for your own safety can cause accidents and serious injuries.

- Always follow the activities in the checklist and follow the general safety precautions.

Changing a wheel

📖 Please read the introductory information and heed the Warnings and Notice ⇒ ⚠ [Introduction](#).

Removing a wheel



Fig. 197 Wheel change: removing wheel bolts with the lug wrench.

1. Follow the checklist ⇒ [Preparations for changing a wheel](#).
2. Loosen the wheel bolts ⇒ [Wheel bolts](#).
3. Raise the vehicle ⇒ [Raising the vehicle with the vehicle jack](#).
4. Remove loose wheel bolts completely using the lug wrench [fig. 197](#) and place the bolts on a clean surface.
5. Remove the wheel.

Installing a spare wheel or compact spare wheel

1. Note the running direction of the tire ⇒ [Tire labeling and tire classifications](#).
2. Position the wheel.
3. Install the anti-theft wheel bolt clockwise using the adapter in the correct position ⇒ [Wheel bolts](#) and lightly tighten.
4. Install all other bolts clockwise and lightly tighten.
5. Lower the vehicle with the vehicle jack.
6. Tighten all wheel bolts securely clockwise using the lug wrench ⇒ ⚠️. Do not go in order around the wheel while doing this, but rather always switch to a wheel bolt on the opposite side.
7. Mount the caps, center wheel covers, or full wheel covers ⇒ [Wheel covers](#).

After a wheel change

1. Clean the vehicle tool kit and place it back in the foam piece in the luggage compartment.
2. Stow the old wheel securely in the luggage compartment.
3. Always check the wheel bolt tightening torque ⇒ [Wheel bolts](#).
4. Always have the damaged wheel replaced as soon as possible.

⚠️ WARNING

An incorrect tightening torque or incorrectly treated wheel bolts can cause the driver to lose control of the vehicle and cause accidents and serious injuries.

- Always keep all wheel bolts and threads in the wheel hubs clean and free of oil and grease. The wheel bolts must be easy to move and tightened to the tightening specification.

 The Tire Pressure Monitoring System (TPMS) indicator light may indicate a system malfunction after a wheel is changed ⇒ [Troubleshooting the Tire Pressure Monitoring System](#).

 If the dimensions of the new tires do not match the dimensions of the tires that have been removed and require a different cold tire pressure, you will need to adapt the tire pressures for the Tire Pressure Monitoring System ⇒ [Tire Pressure Monitoring System](#).

Tire characteristics

Tire labeling and tire classifications

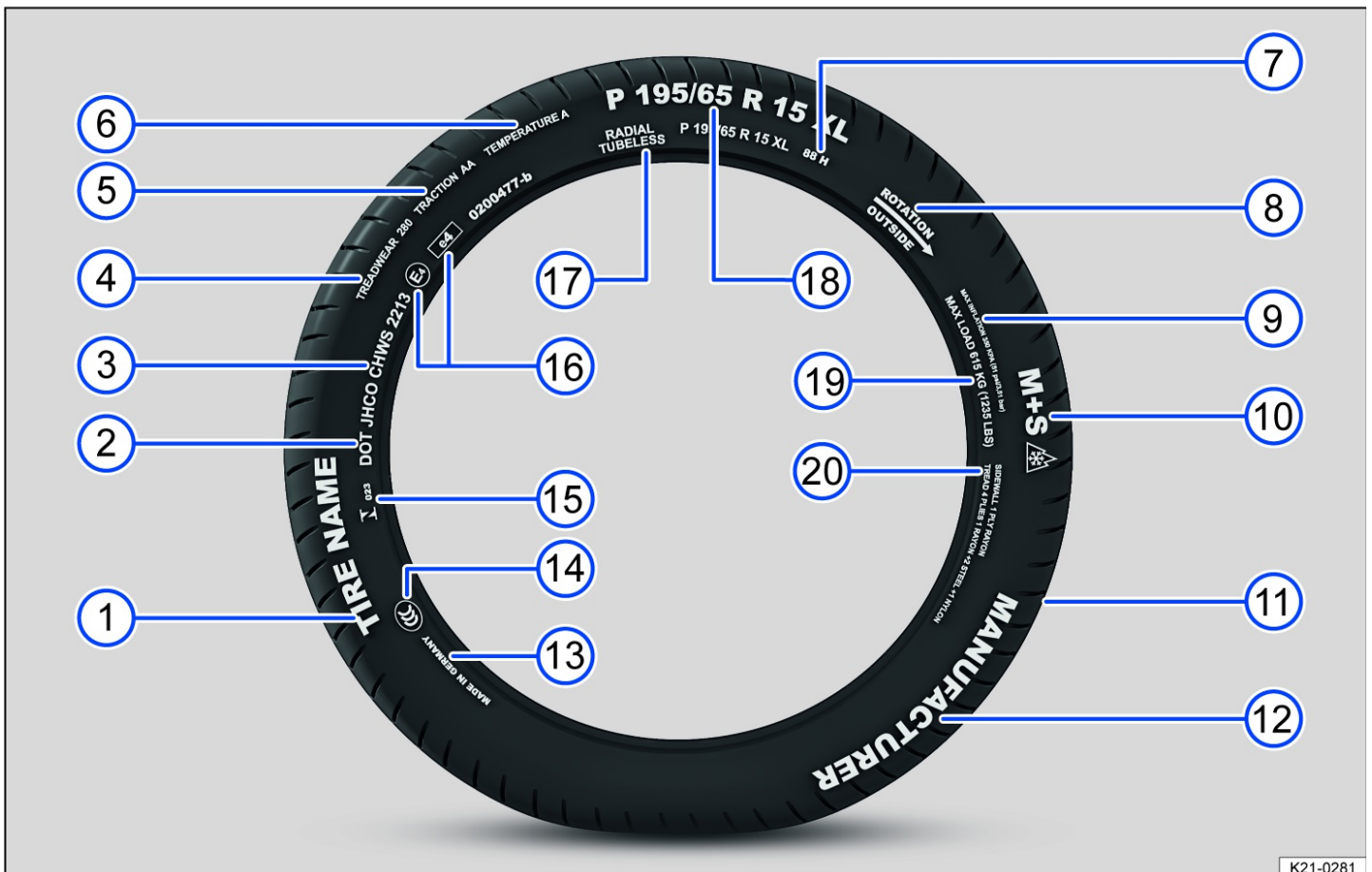





Fig. 198 International tire labeling.

fig. 198 Tire labeling (example), meaning

①	Product name	Individual manufacturer tire designation.	
②	DOT	The tire conforms to the legal requirements of the Department of Transportation in the USA, which is responsible for tire safety standards.	
③	JHCO CHWS 2213	Tire identification number (TIN – may only be on the inner side of the tire) and production date:	
		JHCO CHWS	Code for the factory that produced the tire and specifications from the tire manufacturer for the tire size and tire characteristics.
		2213	Production date: 22nd week in the year 2013.
Information for the end consumer about comparative values for specified base tires (standardized test procedures) ⇒ <i>Customer information</i> :			
④	TREADWEAR 280	Relative service life expectancy for the tire, based on a US-specific standard test. A tire with the specification 280 will wear 2.8 times more slowly than a standard tire with a tread wear value of 100. The tire performance depends on the usage conditions and may differ significantly from the standard values depending on the driving behavior, maintenance, different road conditions, and climate conditions.	
⑤	TRACTION AA	Wet braking capability of the tire (AA, A, B or C). The wet braking capability is measured under controlled conditions on certified test courses. Tires marked with C have low traction performance. The traction value assigned to tires is based on straight-line traction test and includes neither acceleration and cornering, nor hydroplaning and traction under maximum load.	
⑥	TEMPERATURE A	Temperature stability of the tire at high speeds on the test stand A, B or C). Tires marked with A and B exceed the legal requirements. The temperature rating is based on the tires being inflated to the correct pressure and not overinflated. Excess speed, incorrect tire pressure, and overinflation either alone or in combination can cause heat to build up and cause tire damage.	
⑦	88 H	Load index and speed rating .	
⑧	Rotation and arrow	Tire running direction code .	
	Or: Outside	Code on the outside of the tire .	
⑨	MAX INFLATION 350 KPA (51 psi/3.51 bar)	US limit for the maximum inflation pressure.	
⑩	M+S or M/S or 	Code for tires that can be used in the winter (mud and snow tires) ⇒ <i>Winter tires</i> . Studed tires are marked with an E after the S.	
⑪	TWI	Indicates the location of the tread wear indicator ⇒ <i>Monitoring the tread depth</i> .	
⑫	Brand name, logo	Manufacturer.	
⑬	Made in Germany	Country of manufacture.	
⑭		Country-dependent code for China (China Compulsory Certification).	
⑮	 023	Country-dependent code for Brazil.	
⑯	E4 e4 0200477-b	Identification according to international regulations with the number of the country that issued the approval. Approved tires in accordance with ECE regulations are marked with an E. Tires in accordance with EU regulations are marked with an e. The multi-digit approval number follows that.	
⑰	RADIAL TUBELESS	Tubeless radial tires.	
		Size designation:	
		P	Code for passenger vehicles.
		195	Tire width from one sidewall to the other in mm.
		65	Height and width ratio in %.

18	P 195 / 65 R 15 XL <i>fig. 198</i> Tire labeling	(example), meaning						
		<table border="1"> <tr> <td style="text-align: center;">R</td> <td>Belt construction code for radial.</td> </tr> <tr> <td style="text-align: center;">15</td> <td>Rim diameter in inches.</td> </tr> <tr> <td style="text-align: center;">XL</td> <td>Reinforced tires ("Extra Load").</td> </tr> </table>	R	Belt construction code for radial.	15	Rim diameter in inches.	XL	Reinforced tires ("Extra Load").
R	Belt construction code for radial.							
15	Rim diameter in inches.							
XL	Reinforced tires ("Extra Load").							
19	MAX LOAD 615 KG (1235 LBS)	US load capacity for the maximum load per tire.						
	SIDEWALL 1 PLY RAYON	Specification for the components of the tire body. 1 layer rayon.						
□	TREAD 4 PLIES 1 RAYON + 2 STEEL + 1 NYLON	Specification for the components of the running surface. In the example, there are the following 4 layers under the running surface: 1 rayon layer, 2 steel belts, and 1 nylon layer.						

The labeling is on both sides of the tire. In some cases, certain codes may only be on one side of the tire, such as the tire ID number and the production date. Other digits that may be present are part of the internal labeling from the tire manufacturer or country-specific labeling.

Low-profile tires

Compared to other tire-rim combinations, low-profile tires offer a wider tread surface and a larger rim diameter with shorter tire sidewalls. Low-profile tires improve handling performance and precision. However, they may reduce the level of comfort when driving on roads in poor condition.

Unidirectional tires

The sidewalls on unidirectional tires are marked with arrows. The specified running direction must be followed. This ensures the optimum running characteristics. If a tire is mounted opposite from the specified running direction, drive more carefully because the tire is not being used the way it was designed to be used. The tire must be replaced or mounted in the correct running direction as soon as possible.

Asymmetrical tires

Asymmetrical tires factor in the behavior of the inner and outer areas of the tread pattern. The sidewalls on asymmetrical tires are marked as the inner and outer side. Maintain the correct position of the tire on the rim.

Tire load

The tire load index indicates the maximum load of an individual tires in kilograms.

Some examples:

78	425 kg (936 lbs)
81	462 kg (1018 lbs)
83	487 kg (1073 lbs)
85	515 kg (1135 lbs)
87	545 kg (1201 lbs)
88	560 kg (1234 lbs)
91	615 kg (1355 lbs)
92	630 kg (1388 lbs)
93	650 kg (1433 lbs)
95	690 kg (1521 lbs)
97	730 kg (1609 lbs)
99	775 kg (1708 lbs)
100	800 kg (1763 lbs)
101	825 kg (1818 lbs)
102	850 kg (1873 lbs)
103	875 kg (1929 lbs)
104	900 kg (1984 lbs)

Speed rating

The speed rating indicates the maximum speed that may be driven with the tire.

P	max. 93 mph (150 km/h)
Q	max. 99 mph (160 km/h)
R	max. 106 mph (170 km/h)
S	max. 112 mph (180 km/h)
T	max. 118 mph (190 km/h)
U	max. 125 mph (200 km/h)
H	max. 130 mph (210 km/h)
V	max. 149 mph (240 km/h)
W	max. 168 mph (270 km/h)
Y	max. 186 mph (300 km/h)
Z	above 149 mph (240 km/h), depending on manufacturer also ZR .

³⁾The TIN is the tire serial number.

UTQG tire classification

Uniform Tire Quality Grading (UTQG): Quality grades can be found where applicable on the tire sidewall between the tread shoulder and maximum section width.

Example:

- Treadwear (number)
- Traction AA, A, B or C
- Temperature A, B or C

For example: Treadwear 200, Traction AA, Temperature A.

All passenger car tires must conform to Federal Safety Requirements in addition to these grades.

Treadwear

The treadwear grade is a comparative rating based on the wear rate of the tire when tested under controlled conditions on a specified government test course.

For example, a tire graded 150 (Treadwear-value 150) would wear one-and-one-half (1 1/2) times as well on the government course as a tire graded 100.

The relative performance of tires depends upon the actual conditions of their use, however, and may depart significantly from the norm due to variations in driving habits, service practices and differences in road characteristics and climate.

Traction

The traction grades, from highest to lowest, are AA, A, B, and C. Those grades represent the tire's ability to stop on wet pavement as measured under controlled conditions on specified government test surfaces of asphalt and concrete. A tire marked C may have poor traction performance.

Temperature

The temperature grades are A (the highest), B, and C representing the tire's resistance to the generation of heat, and its ability to dissipate heat when tested under controlled conditions on a specified indoor laboratory test wheel.

Sustained high temperature can cause the material of the tire to degenerate and reduce tire life, and excessive temperature can lead to sudden tire failure.

The grade C corresponds to a level of performance which all passenger car tires must meet under the Federal Motor Vehicle Safety Standard No. 109. Grades B and A represent higher levels of performance on the laboratory test wheel than the minimum required by law.

WARNING

The traction class assigned to this tire is based on traction tests when braking straight ahead and does not take account of the properties when accelerating, driving around curves, hydroplaning or at maximum traction.

WARNING

The temperature class for this tire is based on a tire being inflated to the correct pressure and not being overinflated. Excess speeds, insufficient tire pressure, and overinflation either alone or in combination can cause heat to build up and cause potential tire failure.

Tire load and vehicle load, determining the correct load

Vehicles and tires have a limited load capacity. An overloaded vehicle is difficult to steer and brakes less effectively. Overloading your vehicle can also cause damage to the vehicle and tires, such as tire blowouts and sudden pressure losses.

To ensure your safety and the safety of your passengers, never exceed the maximum vehicle weight. This is specified as the **Gross Vehicle Weight Rating (GVWR)**.

The GVWR includes the weight of your vehicle including all additional equipment, a full fuel tank, all fluids and its maximum load. The maximum load includes the number of people that can travel in the vehicle (number of seats) with an average weight of 150 lbs (68 kg) per person, and also luggage. In trailer mode, the weight of the trailer and the trailer tongue weight rating must be included in calculations.

The **Gross Axle Weight Rating (GAWR)** is the maximum axle load per axle. The GVWR and GAWR are listed on the safety certificate on the B-pillar on the driver's side.

Your vehicle has either 4 (2 front, 2 rear), 5 (2 front, 3 rear), 6 (2 front, 2 center, 2 rear) or 7 (2 front, 3 center, 2 rear) seats, depending on the type of vehicle. Each seat has a safety belt. As there is an upper limit to the GVWR, the maximum load also has an upper limit. Traveling with a full vehicle or with passengers heavier than 150 lbs (68 kg) per person will reduce the remaining possible load.

The tire inflation pressure label for your vehicle also specifies the maximum weight.

Determining the correct tire load

Never overload tires. The following example illustrates how to determine the combined weight of all vehicle occupants and luggage or other vehicle payloads. Never overload the vehicle!

Steps for Determining Correct Load Limit:	
1.	Locate the statement "The combined weight of occupants and cargo should never exceed XXX kg or XXX lbs." on your vehicle's placard.
2.	Determine the combined weight of the driver and passengers that will be riding in your vehicle.
3.	Subtract the combined weight of the driver and passengers from XXX kg or XXX lbs.
4.	The resulting figure equals the available amount of cargo and luggage load capacity. For example, if the "XXX" amount equals 1400 lbs. and there will be five 150 lb passengers in your vehicle, the amount of available cargo and luggage load capacity is 650 lbs. $(1400 - 750 (5 \times 150) = 650 \text{ lbs.})$
5.	Determine the combined weight of luggage and cargo being loaded on the vehicle. That weight may not safely exceed the available cargo and luggage load capacity calculated in Step 4.
6.	If your vehicle will be towing a trailer, load from your trailer will be transferred to your vehicle. Consult this manual to determine how this reduces the available cargo and luggage load capacity of your vehicle.
	Check the tire sidewall to determine the load index specified for the tire.

WARNING

Exceeding the maximum vehicle weight can cause you to lose control of the vehicle and cause accidents resulting in severe and/or fatal injuries.

- Never exceed the maximum load or the maximum vehicle weight as per the GVWR.

Glossary of tire and load terminology

Accessory weight: The combined weight (in excess of those standard items which may be replaced) of automatic transmission, electro-mechanical power steering, power brakes, power windows, power seats, radio, and heater, to the extent that these items are available as factory-installed equipment (whether installed or not).

Aspect ratio: The ratio of sidewall height to tire width, expressed as a percentage. A number of 50 (0.5:1 or 50%) means that the cross-sectional height is 50% of the tread width. A shorter sidewall can improve steering response and provide better overall handling, for example, on dry pavement.

Bead: The part of a tire made of steel wires, wrapped or reinforced by ply cords, with the shape and structure to ensure proper fit to the wheel rim.

Bead separation: A breakdown of the bond between components in the bead.

Carcass: The tire structure, except tread and sidewall rubber which, when inflated, bears the load.

Chunking: The breaking away of pieces of the tread or sidewall.

Cord: The strands of material forming the plies in the tire.

Cord separation: The parting of cords from adjacent rubber compounds.

Cracking: Any parting within the tread, sidewall, or inner liner of the tire extending to cord material.

Cold tire inflation pressure: The tire pressure recommended by the vehicle manufacturer for a tire of a specified size that has not been driven for more than a couple of miles (kilometers) at low speeds in the 3 hour period before the tire pressure is measured or adjusted.

Curb weight: The weight of a motor vehicle with standard equipment including the maximum capacity of fuel, oil, and coolant, air conditioner, and additional weight of optional equipment.

Extra load tire: A tire designed to operate at higher loads and at higher inflation pressures than the corresponding standard tire.

Gross Axle Weight Rating (GAWR): The load-carrying capacity of a single axle system, measured where the tire contacts the ground.

Gross Vehicle Weight Rating (GVWR): The maximum loaded weight of the vehicle.

Groove: The space between 2 adjacent tread ribs.

Load rating code: The maximum load that a tire is rated to carry for a given inflation pressure. You may not find this information on all tires because it is not required by law.

Maximum loaded vehicle weight: The total of:

- Curb weight.
- Accessory weight.
- Vehicle capacity weight.
- Production options weight.

Maximum (permissible) inflation pressure: The maximum cold inflation pressure to which a tire may be inflated. Also called “maximum inflation pressure.”

Normal occupant weight: Means 150 lbs (68 kilograms) times the number of occupants seated in the vehicle up to the total seating capacity of your vehicle.

Occupant distribution: The placement of passengers in a vehicle.

Outer diameter: The diameter of a new, properly inflated tire.

Overall width: Total width measured at the exterior sidewalls of an inflated tire, including the additional width of labeling, decorations, or protective bands or ribs.

Passenger car tire: A tire intended for use on passenger cars, multipurpose passenger vehicles, and trucks, that have a gross vehicle weight rating (GVWR) of 10,000 pounds or less.

Ply: A layer of rubber-coated parallel cords.

Ply separation: A parting of rubber compound between adjacent plies.

Pneumatic tire: A mechanical device made of rubber, chemicals, fabric, and steel or other materials, that, when mounted on an automotive wheel, provides the traction and contains the gas or fluid that sustains the load.

Production options weight: The combined weight of installed regular production options weighing over 5 lbs (2.3 kg) more than the standard items they replace, and not previously considered as curb weight or accessory weight. These include, for example, heavy-duty brakes, ride levelers, roof rack, heavy-duty battery, and special trim.

Radial ply tires: A pneumatic tire in which the ply cords that extend to the beads are laid at substantially 90 degrees to the centerline of the tread.

Recommended inflation pressure: The tire pressure recommended by the vehicle manufacturer for a tire of a specified size that has not been driven for more than a couple of miles (kilometers) at low speeds in the 3 hour period before the tire pressure is measured or adjusted.

Reinforced tire: A tire designed to operate at higher loads and at higher inflation pressures than the corresponding standard tire.

Rim: The outer edge of a wheel upon which the tire beads are seated.

Rim diameter: The nominal diameter of the wheel's tire bead seating surface. If you change your wheel size, to wheels of a different diameter, you will have to purchase new tires to match the new wheels.

Rim size: Designation means rim diameter and width.

Rim type designation: The industry or manufacturer's designation for a rim by style or code.

Rim width: The nominal distance between wheel rim flanges.

Section width: The linear distance between the exteriors of the sidewalls of an inflated tire, excluding elevations due to labeling decoration, or protective bands.

Sidewall: The portion of a tire between the bead and the tread.

Sidewall separation: The parting of the rubber compound from the cord material in the sidewall.

Speed rating (letter code): A standardized letter code indicating the maximum speed at which a tire is designed to be driven for extended periods of time. The ratings range from 93 mph (150 km/h) “P” to 186 mph (300 km/h) “Y”. The speed rating letter code, where applicable, is molded on the tire sidewall. You may not find this information on all tires because it is not required by law.

Tire Pressure Monitoring System: A system that detects when at least one of a vehicle's tires is underinflated and illuminates a low tire-pressure warning light.

Tread: The portion of a tire that normally touches the road.

Tread rib: A tread section running circumferentially around a tire.

Tread separation: Tire failure caused by the tread pulling away from the tire carcass.

Tread wear indicators (TWI): Raised areas within the main tread grooves that show, visually, when tires are worn and near the end of their useful life.

Uniform Tire Quality Grading (UTQG): A tire information system developed by the U.S. National Highway Traffic Safety Administration (NHTSA) that is designed to help buyers compare tires. UTQG is not a safety rating, nor is it a guarantee that a tire will last for a certain number of miles or perform a certain way. It gives tire buyers more information to compare with factors such as price, brand loyalty and dealer recommendations. Under UTQG, tires are graded by the tire manufacturer in 3 areas: tread wear, traction and temperature resistance. UTQG information is molded into the tire sidewalls.

U.S. DOT Tire Identification Number (TIN): A tire's serial number. It begins with the letters “DOT” (“Department of Transportation”) and indicates that the tire mee

all federal standards. The next 2 numbers or letters indicate the plant where the tire was manufactured. The last 4 numbers represent the week and year of manufacture. For example, the numbers 1709 mean that the tire was produced in the 17th week of 2009. Any other numbers are marketing codes used by the tire manufacturer. This information is used to help identify affected consumers if a tire defect requires a recall.

Vehicle capacity weight: The total rated cargo, luggage and passenger load. Passenger load is 150 lbs (68 kilograms) times the vehicle's total seating capacity (as listed on the label inside the driver door).

Vehicle maximum load on the tire: The load on an individual tire that is determined by taking each axle's share of the maximum loaded vehicle weight (GAWR) and dividing by 2.

Vehicle normal load on the tire: The load on an individual tire that is determined by taking each axle's share of the curb weight, accessory weight, and normal occupant weight (distributed according to the table below) and dividing by 2.

Wheel size designation: Wheel rim diameter and width.

Occupant loading and distribution for vehicle normal load for various designated seating capacities:

Designated seating capacity, number of occupants	Vehicle normal load, number of occupants	Occupant distribution in a normally loaded vehicle
2, 3, or 4	2	2 in front
5, 6, or 7	3	2 in front, 1 in back

Maintenance

Service

Information regarding the service schedule

Information regarding maintenance of your vehicle and the type and scope of service work can be found in your service schedule. The service schedule is included with your manual Service schedule.

Vehicle care

Vehicle care information

Regular, proper care helps to maintain your vehicle.

The longer dirt remains on the surfaces of vehicle components, the more difficult it may be to clean and care for them. Long-term exposure can make it impossible for dirt to be removed.

For questions regarding care products or for vehicle components that are not listed, consult a suitably qualified professional. Volkswagen recommends contacting an authorized Volkswagen dealer or authorized Volkswagen Service Facility.

Suitably qualified professionals can provide you with suitable accessories. Volkswagen recommends the use of **Genuine Volkswagen Accessories**, which you can acquire from an authorized Volkswagen dealer or authorized Volkswagen Service Facility. Read and follow the usage instructions on the packaging.

WARNING

Improper care and cleaning of vehicle components could impair vehicle safety equipment and cause serious injuries.

- Clean and maintain vehicle components only according to the manufacturer's instructions.
- Always use approved or recommended cleaning solution.
- Never use cleaning solutions that contain solvents. Solvents can cause permanent damage to the airbag module.
- Protect your hands and arms against components with sharp edges, for example when cleaning the inside of the wheel housings.

WARNING

Dirty, foggy, or icy windows reduce visibility and increase the risk of accidents and serious injuries. The vehicle safety equipment could become impaired.

- Only drive when there is clear visibility through all windows.
- Do not use water-repellent window solutions on the windshield. This can cause intense glare under poor visual conditions.

WARNING

Care products can be poisonous and dangerous. Unsuitable care products and incorrect application of care products can cause accidents, serious injuries, burns, and poisoning.

- Only store care products in their sealed original containers.
- Read and follow the package leaflet.
- Keep children away from all care products.
- Only use care products outside or in well-ventilated areas so that no harmful vapors are inhaled.
- Never use turpentine, engine oil, nail polish remover, or other fluids with vapors that dissipate easily for vehicle care. They are poisonous and highly flammable.

NOTICE

Cleaning dirt with aggressive and solvent-based products can cause permanent damage to vehicle equipment, even if only exposed to the vehicle component for a brief period, for example on seat cushions or decorative parts.

- Do not allow dirt to dry.
- Have stubborn spots removed by a suitably qualified, authorized Volkswagen dealer or authorized Volkswagen Service Facility.

Washing the vehicle

 Please read the introductory information and heed the Warnings and Notice  and  Vehicle care information.

Washing your vehicle regularly prevents exposure to contamination, which may damage the paint.

Matte-finish vehicles require special care due to the particular properties of the paint.

To ensure that your vehicle is washed correctly and appropriately, note the following information ⇒  , ⇒ .

WARNING

After a car wash, the braking efficiency may be delayed due to damp or icy brake rotors and brake pads in the winter, and this can increase the braking distance.

- Perform careful braking maneuvers to “dry and remove ice” from the brakes. Do not endanger other road users while doing this.

NOTICE

Improper car washes can increase the risk of severe vehicle damage.

- Always follow the manufacturer's instructions.
- Do not wash the vehicle in direct sunlight.
- In cold weather, never direct a jet of water at locks, doors, or the trunk lid. Vehicle components could freeze.

Removing stubborn dirt on matte paint

- Soak insects or bird excrement that have adhered to the surface immediately with water and spray with a special cleaner for matte paint.
- Remove tar splashes on the paint surface with commercially available tar removers. Residue must not be removed by intensive rubbing.
- Remove tree resin and rust particles with special cleaner for matte paint and a cleaning clay bar. Slide the cleaning clay bar over the affected areas without pressing down on it.
- Spray grease and fingerprints with matte paint finish spray and rub with a soft microfiber cloth.
- Rinse gasoline residue immediately with plenty of water.

Automatic car washes

- If your vehicle has matte paint, never select a wash program with wax or drying aids.
- If your vehicle has matte paint, only use textile car washes, never brush car washes.
- For vehicle with decorative and protective decals, never use a wash package with hot wax.
- Choose car washes without brushes.
- Also ensure that the underside of the vehicle is washed regularly and thoroughly to remove any residue.
- Observe the information provided by the car wash operator, particularly with regard to attachments on the vehicle, e.g. spoilers ⇒ .

✓ The windows are closed and the outside mirrors are folded in.

✓ The vehicle must be in roll mode.

The electronic parking brake is switched off.

✓ Vehicles with steering lock: If the vehicle is mechanically towed in the car wash, the steering must not be locked ⇒ *Steering information*.

✓ The windshield wiper ⇒ *Window wipers* and the rain/light sensor ⇒ *Rain/light sensor* are switched off.

✓ Auto Hold is switched off.

✓ If applicable: the roof antenna has been removed.

NOTICE

Car washes which mechanically scan contours may damage the vehicle, e.g. spoiler.

Pressure washers



Fig. 199 Warning sign: Do not use pressure washers in the marked area.

- Never use rotating nozzles. Observe the manufacturer's instructions.
- Only use water up to maximum +140 °F (+60 °C).
- Move the water jet evenly with a distance of at least 20 inches (50 cm) between the spray nozzle and all parts of the vehicle.
- Do not direct the water at the same spot for a long period of time.
- If possible, do not direct the water straight at sensitive vehicle components, e.g. rubber seals, side windows, glossy trims, tires, sensors, camera lenses, decorative and protective decals.
- Never clean icy or snow-covered door windows with a pressure washer.

Hand washing

Individual contaminations on the paint can be removed with a cleaning clay bar.

1. Clean dust and large dirt deposits from the vehicle with plenty of water.
2. If your vehicle has matte paint, remove insects, grease spots and fingerprints with a special cleaner for matte paint. Apply the product using a microfiber cloth with gentle pressure.
3. Clean the vehicle with a soft sponge, a washing glove, or a washing brush with light pressure. Start at the roof, and continue to work from the top down. Only use a cleansing shampoo on stubborn dirt.

If your vehicle has matte paint, clean from top to bottom with a neutral cleansing shampoo and a microfiber cloth. Wash the microfiber cloth thoroughly at frequent intervals.

4. Clean the wheels and side members with a clean sponge.
5. Rinse with plenty of water.
6. Let the vehicle air dry. Remove water residue with a leather cloth.

NOTICE

Washing the vehicle incorrectly can destroy the matte paint finish.

- Never use washing programs with wax treatment.
- Generally, only cleaning agents free of solids and abrasives, such as cleansing shampoos or insect removers, can be used for cleaning purposes.
- Do not use insect sponges, rough kitchen sponges or similar. The surface may be damaged.

NOTICE

The plenum chamber drain can be blocked by leaves and dirt. Water that cannot drain may leak into the interior. Water introduced manually into the plenum chamber, for example with a pressure washer, can cause considerable vehicle damage.

- Remove leaves or other loose objects with a vacuum or by hand.
- Have the area under the perforated cover cleaned by an authorized Volkswagen dealer or authorized Volkswagen Service Facility.

 Only wash the vehicle in facilities specifically designed for that purpose. This will reduce the risk of water contaminated with oil from entering the sewer system.

Exterior care and cleaning

 Please read the introductory information and heed the Warnings and Notice  and  Vehicle care information.

The following overview gives recommendations for cleaning and caring for individual vehicle components.

Door windows, glass surfaces

- Remove wax residue, for example from care products, with a suitable glass cleaner or the Volkswagen Genuine cleaning cloth.
- Remove snow with a hand brush.
- Remove ice with a plastic scraper. When doing so, scrape in one direction only.
- Defrost the ice with a suitable deicer or Volkswagen Genuine deicer.
- Clean wiper blades or change them if necessary.

Paint

Always treat surfaces with extreme care to prevent paint damage.

- Treat light contaminants, for example deposits, insects, and cosmetics, immediately with a clean soft towel and a mild soap solution of maximum two tablespoons of neutral soap in a liter of water, or with a cleaning clay bar.
- Clean spilled fuel or operating materials immediately.
- Dampen rust spots with soap solution. Then remove with a cleaning clay bar.
- Have corrosion removed by suitably qualified professionals. Volkswagen recommends contacting an authorized Volkswagen dealer or authorized Volkswagen Service Facility.
- In the event of paint damage, consult suitably qualified professionals and have the paint damage repaired. Volkswagen recommends contacting an authorized Volkswagen dealer or authorized Volkswagen Service Facility.

A preservation treatment protects the vehicle paint. When water no longer clearly beads up and drips off *clean* vehicle paint, the vehicle should be retreated with a wax protectant if not earlier.

- For **matte paint**, use a soft sponge to apply a special wax for matte paint to the cleaned vehicle. Remove excess wax with a microfiber cloth.
- Even if a wax protectant is applied regularly in an automatic car wash, Volkswagen recommends protecting the vehicle paint at least twice a year with a suitable hard wax or Volkswagen Genuine hard wax.
- Polishing is only needed if the appearance of the vehicle paint is poor and a shiny finish can no longer be achieved using protectants.

Never polish matte-finish surfaces. The surface will be permanently damaged by the paint shining.

Plenum chamber, engine compartment

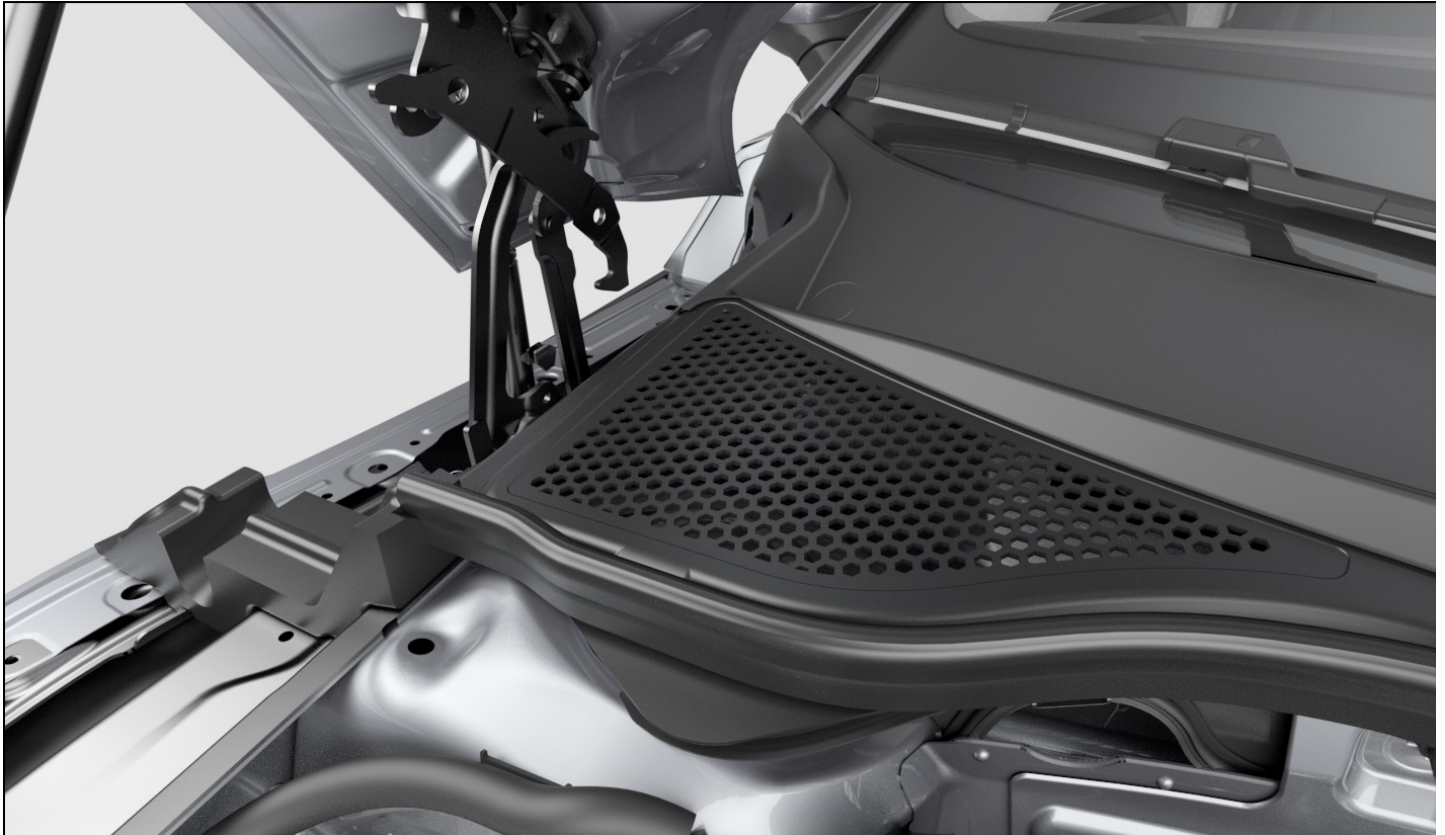

Fig. 200 Between the engine compartment and windshield: plenum chamber (general example).

- Remove leaves or other loose objects with a vacuum or by hand *fig. 200*, ⇒ ⚠.
- Always have the engine compartment cleaned by an authorized Volkswagen dealer or authorized Volkswagen Service Facility qualified in this respect ⇒ ⚠. Volkswagen recommends contacting an authorized Volkswagen dealer or authorized Volkswagen Service Facility.

Water introduced manually into the plenum chamber, for example with a pressure washer, can cause considerable vehicle damage.

! NOTICE

The plenum chamber drain can be blocked by leaves and dirt. Water that cannot drain may leak into the interior.

- Have the area under the perforated cover regularly cleaned by an authorized Volkswagen dealer or authorized Volkswagen Service Facility qualified in this respect. Volkswagen recommends contacting an authorized Volkswagen dealer or authorized Volkswagen Service Facility.

Sensors, camera lenses



Fig. 201 In the rear of the vehicle: Rear View Camera system in the Volkswagen emblem (general example).

- Clean the area in front of the sensors or the camera with a soft cloth and solvent-free cleaning solution.
- Clean sensitive surfaces of the rain/light sensor and the camera window on the windshield as you would **windows and glass surfaces** (depending on the equipment).
- Remove snow with a hand brush.
- Never use warm or hot water.
- Defrost the ice with a suitable deicer or Volkswagen Genuine deicer.

Cleaning the Rear View Camera system

1. Switch the ignition on.
2. Engage the **R** selector lever position.
3. Set the electronic parking brake.
4. Clean the camera lens.

Decorative and protective decals

- Remove contaminants as described for **paint**. For matte decorative decals, use a suitable plastic cleaner or a Volkswagen Genuine plastic cleaner.
- Treat the vehicle every three months with liquid hard wax. The vehicle must be free of dirt and dust before treating. Apply using only clean, soft microfiber cloths. **Do not use hot wax**, even in a car wash.
- Hard contaminants: remove gently with ethyl alcohol and then wash with warm water.

i **The durability and coloring on decorative and protective decals can be affected by environment conditions, such as sunlight, moisture, air pollution, stone chips, etc. Decorative decals may show signs of wear and aging after approximately one to three years, and protective decals after approximately two to three years. In very hot climates, the decorative decals may fade slightly within one year and the protective decals within two years.**

Trims made out of chrome-plated plastic, aluminum or stainless steel

- Clean surfaces with a suitable chrome and aluminum product or Volkswagen Genuine chrome and aluminum products.
- Chrome-plated trims can be protected with a suitable hard wax or Volkswagen Genuine hard wax.

Headlights, taillights

- Use a soft sponge saturated with a mild soap solution of maximum two tablespoons of neutral soap in a liter of water to remove dirt. Do not use cleaning solutions containing alcohol and/or solvents.
- Remove stubborn dirt with a suitable chrome and aluminum product or Volkswagen Genuine chrome and aluminum products.

Wheels

- Remove contaminants and road salt with plenty of water.
- Clean dirty alloy wheels with a suitable rim cleaner or with Volkswagen Genuine rim cleaner. Volkswagen recommends applying a suitable hard wax or Volkswagen Genuine hard wax to the rims every three months.
- Repair a damaged protective paint layer immediately with a paint pen. If necessary, contact an authorized Volkswagen dealer or authorized Volkswagen Service Facility. Volkswagen recommends contacting an authorized Volkswagen dealer or authorized Volkswagen Service Facility.
- Remove brake dust with a suitable rim cleaner or Volkswagen Genuine rim cleaner.

Door lock cylinder

1. Defrost the door lock cylinder with a suitable door lock deicer or Volkswagen Genuine deicer.

Do not use any door lock deicers with degreasing substances.

WARNING

The engine compartment is a dangerous area in any vehicle. There is a risk of injury, scalding, accidents, and burns when performing any work in the engine compartment.

- Always note the necessary handling guidelines and the safety precautions every time before working in the engine compartment → page , *Safety precautions for working in the engine compartment*.
- Have all the work performed by suitably qualified professionals. Volkswagen recommends contacting an authorized Volkswagen dealer or authorized Volkswagen Service Facility.

NOTICE

Incorrect cleaning and care can cause vehicle damage.

- Always follow the manufacturer's instructions.
- Never use cleaning objects that are too hard or abrasive.

Interior care and cleaning

 Please read the introductory information and heed the Warnings and Notice ⇒  and  *Vehicle care information*.

The following overview gives recommendations for cleaning and caring for individual vehicle components.

NOTICE

Incorrect cleaning and care can cause vehicle damage.

- Never use steam cleaners, brushes, hard sponges, etc.
- Have tough spots removed by an authorized Volkswagen dealer or authorized Volkswagen Service Facility.

Door windows

- Clean the door window with a glass cleaner.
- Wipe the door windows dry with a clean chamois or a lint-free cloth.

Textiles, microfiber, leatherette

- Regularly remove dirt particles that adhere to the surface with a vacuum cleaner so that the material is not permanently damaged by scrubbing.
- Remove contaminants with a suitable interior cleaner or Volkswagen Genuine interior cleaner.
- For grease-based contaminants such as oil, use a suitable interior cleaner or Volkswagen Genuine interior cleaner. Blot away the dissolved grease or dye with an absorbent towel. If necessary, treat afterwards with water.
- For contaminants, for example from pens or nail polish, use a suitable interior cleaner or Volkswagen Genuine interior cleaner. If necessary, treat afterward with a mild soap solution of maximum two tablespoons of neutral soap in a liter of water.
- Never use leather cleaners, solvents, floor polish, shoe polish, paint remover, or other similar substances.
- Never use pressure washers, steam cleaners or cooling sprays.

Natural leather

- Remove fresh dirt with a cotton cloth and a mild soap solution of maximum two tablespoons of neutral soap in a liter of water. Do not let any fluids seep into the cracks.
- For contaminants, for example from pens or nail polish, use a suitable leather cleaner or Volkswagen Genuine leather cleaner.
- Treat dried spots with a suitable leather cleaner or with Volkswagen Genuine leather cleaner.

- Remove any fresh spots of grease such as oil with an absorbent cloth.
- Apply leather care to seats regularly and each time you clean. If leaving the vehicle parked for long periods of time, you should cover the leather to protect it from direct sunlight.

Never treat leather with solvents, floor polish, shoe polish, paint remover, or other similar substances.

Plastic parts

- Clean with a soft, damp cloth.
- If a mild soap solution of maximum two tablespoons of neutral soap in a liter of water cannot remove stubborn stains, use a solvent-free plastic cleaner or Volkswagen Genuine plastic cleaner, if necessary.

Trims, decorative trims made out of chrome, aluminum or stainless steel

- Clean using a clean, soft towel and mild soap solution of maximum two tablespoons of neutral soap in a liter of water, in a dust-free area.
- Treat anodized surfaces with a suitable chrome and aluminum product or Volkswagen Genuine chrome and aluminum products.

Controls

1. Use a soft brush to remove large dirt deposits as well as any dirt that is difficult to reach.
2. Use a clean, soft cloth and a fairly mild soap solution of maximum two tablespoons of neutral soap in a liter of water. Fluids must not enter into the controls.

Displays and screens

Do not clean the instrument cluster display and the Infotainment system screen when they are dry.

1. Turn off the Infotainment system temporarily to clean it.
2. Use a suitable cleaning cloth or Volkswagen Genuine cleaning cloth with some water, suitable glass cleaner, or an LCD cleaner.

Rubber seals

- Clean with a soft, lint-free cloth and plenty of water.
- Treat regularly with a suitable rubber care product or Volkswagen Genuine rubber care product.

Safety belts

1. Unreel the safety belt completely and leave the belt unreeled.
2. Remove large spots of dirt with a soft brush.
3. Clean the safety belt with a mild soap solution of maximum two tablespoons of neutral soap in a liter of water.
4. Let the belt webbing dry completely, then allow the belt to retract.

⚠ WARNING

Improper cleaning can cause damage to the safety belts, anchors, and the automatic safety belt retractors.

- Never attempt to modify or remove the safety belts to clean them.
- Never use chemical products to clean the safety belts and their components.
- Do not use any corrosive fluids, solvents, or sharp objects.
- Do not allow fluids and objects to enter the safety belt buckle.
- Let the safety belt dry after cleaning before allowing it to retract completely.

Wood trims

Clean with a soft cloth and fairly mild soap solution of maximum two tablespoons of neutral soap in a liter of water.

Cleaning the seat covers

If dye from clothing such as denim stains the seat covers, this is not considered a defect in the vehicle upholstery. Airbag system components and connectors may be installed in the seat covers. Damage, incorrect cleaning and handling, or moisture can also cause an airbag system malfunction as well as damage to the vehicle electrical system ⇒ ⚠.

Depending on the equipment, electrical components and connectors may be installed in the seat surface with seat heating, which can be damaged by incorrect cleaning or handling. This can also result in damage to other areas of the vehicle electrical system.

- Never use pressure washers, steam cleaners or cooling sprays.
- Never soak seat covers.
- Never switch on seat heating to dry the seats.
- Do not use detergent pastes or mild detergent solutions.

- If there is uncertainty, contact suitably qualified professionals for assistance. Volkswagen recommends contacting an authorized Volkswagen dealer or authorized Volkswagen Service Facility.

WARNING

Improper care and cleaning of vehicle components could impair vehicle safety equipment and cause serious injuries.

- Clean and maintain vehicle components only according to the manufacturer's instructions.

 **Needless to say, it is easier to see signs of wear and dirt caused by normal usage on bright materials in the vehicle interior. These signs of use are unavoidable and also indicate the unavoidable deterioration caused by normal usage. Please follow the corresponding care instructions.**

Accessories, replacement parts, repairs, and modifications

Accessories and replacement parts

Consult an authorized Volkswagen dealer or authorized Volkswagen Service Facility before purchasing Genuine Volkswagen Accessories, replacement parts, or operating equipment, for example if you would like to retrofit the vehicle with Genuine Volkswagen Accessories or if parts need to be replaced. The authorized Volkswagen dealer or authorized Volkswagen Service Facility is aware of legal regulations and factory recommendations for Genuine Volkswagen Accessories, replacement parts, and operating equipment. Volkswagen recommends contacting an authorized Volkswagen dealer or authorized Volkswagen Service Facility.

Volkswagen recommends the use of Volkswagen original parts or Volkswagen original accessories, which you can acquire from an authorized Volkswagen dealer or authorized Volkswagen Service Facility. Volkswagen has verified their reliability, safety, and suitability. A suitably qualified authorized Volkswagen dealer or authorized Volkswagen Service Facility also specializes in correct installation. Volkswagen recommends contacting an authorized Volkswagen dealer or authorized Volkswagen Service Facility.

Products that are not approved by Volkswagen may not have been evaluated by Volkswagen regarding the reliability, safety, and suitability for the vehicle, despite ongoing market observation. Therefore, Volkswagen can also not be responsible in individual cases if approval is given by an officially-recognized technical inspection and control authority or clearance is given by a government agency.

You must consult a suitably qualified authorized Volkswagen dealer or authorized Volkswagen Service Facility to replace rim/tire combinations. Volkswagen recommends contacting an authorized Volkswagen dealer or authorized Volkswagen Service Facility.

Retrofitted devices that have a direct effect on vehicle control, must have an **e** symbol (the approval symbol for the European Union) and be approved by Volkswagen for the vehicle. Such devices could include a cruise control system or an electronically-controlled damping system.

Additional electrical devices that do not have a direct effect on vehicle control must have a **a** symbol (manufacturer's Declaration of Compliance for the European Union). Such devices could include refrigerators, computers, or ventilators.

WARNING

Unsuitable accessory parts and replacement parts may cause vehicle damage, malfunctions, accidents and severe injuries.

- Volkswagen recommends the use of Volkswagen Genuine Parts® or Genuine Volkswagen Accessories, which you can acquire from an authorized Volkswagen dealer or authorized Volkswagen Service Facility.
- Only install parts on the vehicle whose design and function are identical to the parts installed at the factory.
- Only use rim/tire combinations that are approved by Volkswagen for your vehicle model.

WARNING

Items in the deployment zone of the airbag may cause serious or fatal injuries if the airbags deploy.

- Never attach or position objects in the airbag deployment zone.

NOTICE

Unsuitable accessories and replacement parts may cause vehicle damage and malfunctions.

Retrofitting an engine preheating system may damage certain engines.

- Consult an authorized Volkswagen dealer or authorized Volkswagen Service Facility about the intended engines for retrofitting an engine preheating system. Volkswagen recommends contacting an authorized Volkswagen dealer or authorized Volkswagen Service Facility.

Repairs and technical modifications

Volkswagen guidelines must be followed when performing repairs and technical modifications ⇒ .

Interference with electronic components and their software can cause malfunctions. Because of the way electronic components are interconnected, such malfunctions can also impair systems that are not directly involved. This means that you risk both a substantial reduction in the operational safety of your vehicle and increased wear of vehicle components.

An authorized Volkswagen dealer or authorized Volkswagen Service Facility cannot assume any liability for damage resulting from repairs and technical modifications that were performed incorrectly.

An authorized Volkswagen dealer or authorized Volkswagen Service Facility is not responsible for damage resulting from repairs and technical modifications that were performed incorrectly. Such damages are also not covered by the Volkswagen warranty.

Have all repairs and technical modifications performed by suitably qualified professionals. Volkswagen recommends contacting your authorized Volkswagen dealer or authorized Volkswagen Service Facility for Volkswagen Genuine Parts®.

Volkswagen repair information

Volkswagen service information and official Volkswagen repair information can be purchased.

Customers in Europe, Asia, Australia, Africa, Central and South America:

Contact suitably qualified professionals for assistance. Volkswagen recommends contacting an authorized Volkswagen dealer or authorized Volkswagen Service Facility. Or register with the **erWin** (electronic repair and service information) web portal:

<https://erwin.volkswagen.de>

Customers in North America and Canada:

If you wish to order the printed service information, please contact:

Volkswagen Technical Literature Ordering Center literature.vw.com

You can also register for the **erWin** web portal:

<https://erwin.vw.com>

Diagnostic connection (on-board diagnosis)

In the vehicle interior, there is a diagnostic connection (OBD) to read event memories. Event memories document faults that have occurred and deviations from specified values from the control module ⇒ .

The diagnostic connection (OBD) is located in the footwell on the driver's side on the underside of the instrument panel or next to the hood release lever behind a cover.

Only have the event memory read out and reset by suitably qualified professionals. Additional information about the saved data can be obtained from suitably qualified professionals. Volkswagen recommends contacting an authorized Volkswagen dealer or authorized Volkswagen Service Facility.

After a malfunction is fixed, the information about it will be deleted from the event memory. Other memory content is overwritten continuously.

Vehicles with special modifications and mountings

The attachment and mounting manufacturer should make sure that the applicable environmental laws and regulations are met for the attachments and mountings, especially the EU directive 2000/53/EG about old vehicle and EU directive 2003/11/EG about market introduction restrictions and the use of certain hazardous materials and compounds.

The installation instructions for any retrofitted equipment should be saved by the vehicle owner and provided to the removal facility if the vehicle is scrapped. This ensures that even vehicles with retrofitted equipment will be disposed of in a way that will not harm the environment.

Windshield repairs

To perform functions, some equipment requires an electric or electronic component that is secured to the inside of the windshield near the interior rearview mirror, for example. If the windshield is damaged within the area covered by the electrical or electronic component's visual field, for example with a stone chip, then the windshield must be replaced. Stone chip repairs can cause malfunctions in the equipment.

After a windshield is replaced, the camera and sensors must be adjusted and calibrated by suitably qualified professionals. Volkswagen recommends contacting an authorized Volkswagen dealer or authorized Volkswagen Service Facility.

Impairment or damage to sensors and cameras

The sensors or cameras could shift or become damaged as a result of incorrect repairs, structural changes to the vehicle (such as "lowering"), installation of after-market equipment, or changes to the trim panels. This can also be caused by collisions when parking and by minor damage, such as a stone hitting the windshield.

The area in front of and around the sensors and cameras must not be covered by stickers, auxiliary headlights, decorative license plate frames, or similar objects. Note the position of sensors and cameras on your vehicle in the vehicle overviews.

! NOTICE

Additionally affixed foils and paint on and above the sensors can impair the function of the sensors.

- If there is damage in the area of the sensors in the bumper, have the component replaced by a suitably qualified professional. Volkswagen recommends contacting an authorized Volkswagen dealer or authorized Volkswagen Service Facility.

If ignored, important vehicle functions of driver assistance systems could be impaired and vehicle damage could result.

Have repairs or structural changes performed by suitably qualified professionals. Volkswagen recommends contacting an authorized Volkswagen dealer or authorized Volkswagen Service Facility.

Additional information:

- Painting near the sensors can impair the function of the system that uses those sensors.
- The Volkswagen emblem can impede the view of the radar sensors to the front on some vehicle versions. Therefore only operate the vehicle with the original Volkswagen emblem or an emblem approved by Volkswagen.

Engine/motor protection

Engine/motor protection can reduce the risk of damage to the vehicle underbody and the oil pan, for example if driving over curbs, entering driveways, or on unpaved roads.

Have the retrofitting work performed by suitable qualified professionals. Volkswagen recommends contacting an authorized Volkswagen dealer or authorized Volkswagen Service Facility.

Engine/motor protection may not be available in all countries.

WARNING

Repairs and modifications to the vehicle that are performed incorrectly can impair the effectiveness of the driver assistance systems and deploying airbags. This can cause malfunctions, accidents and fatal injuries.

- Only have suitably qualified professionals make repairs or modifications to a vehicle. Volkswagen recommends contacting an authorized Volkswagen dealer or authorized Volkswagen Service Facility.

WARNING

Repairs and modifications to the vehicle that are performed incorrectly may cause vehicle damage, accidents and severe injuries.

- Volkswagen recommends the use of Volkswagen original parts or Volkswagen original accessories, which you can acquire from an authorized Volkswagen dealer or authorized Volkswagen Service Facility. Volkswagen has verified their reliability, safety, and suitability.
- Only have suitably qualified professionals make repairs or modifications to a vehicle. Authorized Volkswagen dealers and authorized Volkswagen Service Facilities have the required tools, diagnostic devices, repair information, and qualified personnel. Volkswagen recommends contacting an authorized Volkswagen dealer or authorized Volkswagen Service Facility.
- Only install parts on the vehicle whose design and function are identical to the parts installed at the factory.
- Only use rim/tire combinations that are approved by Volkswagen for your vehicle model.

WARNING

Incorrect use of the diagnostic connection can cause malfunctions, which can then result in collisions and serious injuries.

- Never read out the event memory yourself using the diagnostic connection.
- Never load data yourself using the diagnostic connection in the vehicle.
- Only have the event memory read out with the diagnostic connection by suitably qualified professionals. Volkswagen recommends contacting an authorized Volkswagen dealer or authorized Volkswagen Service Facility.

Airbag system repairs and situations that can affect the system function

Volkswagen guidelines must be followed when performing repairs and technical modifications ⇒ .

Only have modifications and repairs on the front bumper, doors, front seats, headliner, or vehicle body performed by an authorized Volkswagen dealer or authorized Volkswagen Service Facility. Volkswagen recommends contacting an authorized Volkswagen dealer or authorized Volkswagen Service Facility. Airbag system components and sensors may be located on these vehicle components.

Airbag system components can be damaged during all procedures on the airbag system and when removing and installing system components while performing other repair procedures. This may prevent the airbags from deploying or cause them to deploy incorrectly in the event of an accident.

The instructions must be followed so that the effectiveness of the airbags is not impaired and removed components do not cause injuries and environmental pollution. An authorized Volkswagen dealer or authorized Volkswagen Service Facility will be familiar with these provisions. Volkswagen recommends contacting an authorized Volkswagen dealer or authorized Volkswagen Service Facility.

A modification to the vehicle suspension can impair the functionality of the airbag system during a collision. For example, using a rim/tire combination that is not approved by Volkswagen, lowering the vehicle, or changing the suspension stiffness including the springs, suspensions struts, shock absorbers, etc., can change the force that is measured by the airbag sensors and transmitted to the electronic control module. For example, some changes to the suspension can increase the force measured by the systems and trigger the airbag system in accidents where the airbags would normally not be deployed if the modifications had not been made. Other modifications can reduce the force measured by the sensors and prevent the airbag from deploying when it should have deployed.

WARNING

Repairs and modifications that were done incorrectly can cause damage and malfunctions to the vehicle as well as impair the effectiveness of the airbag system. This can cause accidents and serious or fatal injuries.

- Only have suitably qualified professionals make repairs or modifications to a vehicle. Volkswagen recommends contacting an authorized Volkswagen dealer or authorized Volkswagen Service Facility.
- The airbag module cannot be repaired; it must be replaced.
- Never install airbag components removed from old vehicles or from recycling.

WARNING

A modification to the vehicle suspension including using a rim/tire combination that is not permitted can change the functionality of the airbag and increase the risk of severe or fatal injuries in an accident.

- Never install suspension components that do not have the same properties as the original parts installed in the vehicle.
- Never use rim/tire combinations that are not approved by Volkswagen.

Mobile phone usage in the vehicle

Electromagnetic waves

When using a mobile phone or radio equipment without connecting to the exterior antenna, the electromagnetic waves will not be deflected outward in an optimum way. Increased waves in the vehicle interior can occur, especially when reception is poor, for example in rural areas. This could be a potential health risk ⇒ .

Depending on the equipment, it may be possible to use a suitable telephone interface to connect the mobile phone to the exterior antenna. This will improve the connection quality and increase the range.

Using a phone

In many countries, using a phone in the vehicle is only permitted if there is a hands-free connection, for example using a Bluetooth[®] connection. Before using the phone, secure it in a suitable holder ⇒  or store it in a storage compartment, such as in the center console, to prevent it from sliding around.

Radio

If operating radio devices, follow the legal regulations and the user guide from the manufacturer. The aftermarket installation of radio devices is subject to approval.

Contact qualified professionals for more information about installing radio equipment. Volkswagen recommends contacting an authorized Volkswagen dealer or authorized Volkswagen Service Facility.

WARNING

Mobile devices that are loose or not secured correctly can be thrown through the vehicle interior during sudden driving or braking maneuvers or in the event of a collision and cause injuries.

- Secure or store the mobile phone and accessories safely outside the deployment range of the airbags.

WARNING

Using a mobile device or radio equipment inside the vehicle without a connection to an exterior antenna may create electromagnetic energy that exceeds permissible limits. This may be dangerous to your health and that of your passengers. This also applies if the exterior antenna is not installed correctly.

- Maintain a distance of at least 8 inches (20 cm) between the device antennae and any active medical implants, such as pacemakers.
- Do not carry a mobile device that is turned on directly above or in the immediate vicinity of any active medical implants, for example by keeping a phone in a shirt pocket.
- Switch off the mobile device immediately if you suspect there is interference with an active medical implant or other medical device.

Customer information

Warranty

Warranty

Your vehicle is covered by various warranties:

- New Vehicle Limited Warranty.
- Limited Warranty Against Corrosion Perforation.
- Emissions Control System Warranties: Federal Emissions Control System Defect Warranty, Federal Emissions Performance Warranty.
- US battery electric vehicles: High-Voltage System Limited Warranty.
- US models: Kansas Safety Belt Limited Warranty.
- US models: California Emissions Control System Warranties: Short-term Emissions Defects Warranty, Long-term Emissions Defect Warranty, California Emissions Performance Warranty.

You can find the detailed information in your Warranty & Maintenance Booklet and California Emissions Booklet or on the website:

maintenance.vw.com

Event data recorder (crash data recorder)

This vehicle is equipped with an event data recorder (EDR). The main purpose of an EDR is to record, in certain crash or near crash-like situations, such as an air bag deployment or hitting a road obstacle, data that will assist in understanding how a vehicle's systems performed. The EDR is designed to record data related to vehicle dynamics and safety systems for a short period of time, typically 30 seconds or less. The EDR in this vehicle is designed to record such data as:

- How various systems in your vehicle were operating;
- Whether or not the driver and passenger safety belts were buckled/fastened;
- How far (if at all) the driver was depressing the accelerator and/or brake pedal; and,
- How fast the vehicle was traveling.

These data can help provide a better understanding of the circumstances in which crashes and injuries occur.

In addition, data from the driver assistance systems is also collected. In addition to information about whether these systems were switched on or off, had limited availability, or were inactive, it can also be understood if these functions steered, accelerated, or braked the vehicle in the situations listed above. Depending on the vehicle equipment, systems may include:

- Adaptive Cruise Control (ACC).
- Lane Assist
- Park Assist
- Parking systems
- Autonomous Emergency Braking Function (Front Assist)

NOTE: EDR data are recorded by your vehicle only if a non-trivial crash situation occurs; no data are recorded by the EDR under normal driving conditions and no personal data (e.g., name, gender, age, and crash location) are recorded. However, other parties, such as law enforcement, could combine the EDR data with the type of personally identifying data routinely acquired during a crash investigation.

To read data recorded by an EDR, special equipment is required, and access to the vehicle or the EDR is needed. In addition to the vehicle manufacturer, other parties, such as law enforcement, that have the special equipment, can read the information if they have access to the vehicle or the EDR.

Volkswagen will not access, read or process the Event Data Recorder (EDR) data unless the vehicle owner gives permission. This excludes contractual or legal regulations.

Due to the legal obligation to monitor products, Volkswagen is allowed to use data for field observation as well as for research purposes and quality improvement of vehicle safety systems. For research purposes, Volkswagen provides the data to third parties in an anonymous format. This means the data does not reference the individual vehicle or the vehicle owner.

Labels and signs

Factory labels and signs with important information regarding vehicle operation are located in the engine compartment and on several vehicle components.

- Never remove these labels and signs or make them illegible.
- If vehicle components equipped with labels and signs are replaced, suitably qualified professionals must place identical labels and signs correctly in the same locations on the new components. Volkswagen recommends contacting an authorized Volkswagen dealer or authorized Volkswagen Service Facility.

Safety certificate

A safety certificate on the driver's door jamb specifies all necessary safety standards and guidelines of the traffic safety authorities in the applicable country at the

time of manufacture. The month and year of production as well as the VIN may also be listed. Read the information in the Owner's Manual.

⚠ WARNING

Incorrect vehicle handling increases the risk of accidents and injuries.

- Follow the legal regulations.
- Follow the Owner's Manual instructions.

ⓘ NOTICE

Incorrect vehicle handling can cause vehicle damage.

- Follow the legal regulations.
- Perform service according to the specifications.

Fluids in the air conditioning system

Refrigerant in the air conditioning system

The label in the engine compartment provides information about the type and amount of refrigerant used in the vehicle air conditioning system. The label is in the front section of the engine compartment near the refrigerant filler tubes ⇒ ⚠.

⚠ Warning: the air conditioning system must only be serviced by qualified technicians. ⚙ Refrigerant type. ⚙ Type of refrigerant oil. 📖 See service information (only available for authorized Volkswagen dealers and authorized Volkswagen Service Facilities). 🛠 The air conditioning system must only be serviced by qualified technicians. 🔥 Flammable refrigerant. ♻ Make sure all components are disposed of correctly and never install components removed from old vehicles or from recycling in the vehicle.

Refrigerant oil in the air conditioner

The air conditioner is filled with refrigerant oil. The label on the air conditioner compressor provides information on the type and quantity of refrigerant oil used ⇒ [Repairs and technical modifications](#).

⚠ WARNING

To ensure safe operation, the air conditioner may only be serviced by an authorized Volkswagen dealer or authorized Volkswagen Service Facility qualified in this respect.

ⓘ NOTICE

- Never repair the air conditioning system evaporator with replacement parts from old vehicles or from the recycling, or replace it with such replacement parts.
- A replacement part for the air conditioning system evaporator must be certified and marked in accordance with SAE standards J2842 HFO-1234y and R744.
- The air conditioner must only be serviced by qualified technicians who are trained according to SAE standard J2845 and certified according to SAE standard J2911. SAE standard J639 must be complied with while working on the air conditioner. Refrigerant labels that are damaged or no longer present (in the engine compartment) must be replaced

Infotainment system and aerials

The aerials for the Infotainment system are fitted in various places in the vehicle:

- On the inside of the rear window.
- On the roof of the vehicle

Antennas on the inside of the window glass can be detected as thin wires.

ⓘ NOTICE

Antennas that are located on the inside of the window glass can be damaged by abrasive objects or by corrosive and acidic materials.

- Never apply stickers over metal wires, for example on the rear window.
- Never clean the antennas with corrosive or acidic materials.

ⓘ NOTICE

A retrofitted Infotainment system must be compatible with the antenna amplifier installed in the vehicle by the manufacturer. Otherwise, the antenna amplifier

could become damaged.

Component protection

Some electronic components and control modules, such as the Infotainment system, are equipped with component protection at the factory.

The component protection allows suitably qualified professionals to legitimately install or replace components and control modules. Volkswagen recommends contacting your Volkswagen dealership.



In the following situations, component protection reduces the risk of components supplied by the factory being operated without restrictions outside the vehicle.

- Installation in other vehicles, for example the components have been stolen
- Operating components outside of the vehicle

If a message about component protection appears in the instrument cluster display or on the Infotainment system screen, contact a suitably qualified professional for assistance. Volkswagen recommends contacting your Volkswagen dealership.

Disposal of old batteries and electronic devices

Old batteries

As with electronic devices, old batteries must be collected and recycled separately by the end user. These batteries are indicated by the crossed-out wheeled garbage can symbol . You, as the end user, are legally obliged to return old batteries ⇒ .

- In many federal states, old batteries can be handed in to an authorized Volkswagen dealer or authorized Volkswagen Service Facility.
- You can obtain more information on return and recycling from your authorized Volkswagen dealer or authorized Volkswagen Service Facility.

Old electrical or electronic devices

Your vehicle contains old electrical/electronic devices, such as the navigation system SD card or remote controls. You can recognize these from the symbol of the crossed-out wheeled garbage can .

Old devices with this marking must be collected separately from normal household garbage and disposed of in accordance with legal requirements.

- Batteries within devices that are not permanently installed must be removed beforehand and disposed of separately as batteries.
- Any saved personal data must be erased before disposal of old devices.

You can obtain more information on return and recycling from your authorized Volkswagen dealer or authorized Volkswagen Service Facility.

WARNING

Handling lithium-containing batteries requires particular care. For instance, damage can cause gaseous or liquid substances to escape, which pose a significant risk to health and the environment. A short circuit at the battery terminal may also result in a fire or explosion.

- Never heat up lithium-containing batteries.
- Never damage lithium-containing batteries.
- Never short circuit the battery terminals.

 Batteries containing heavy metals are marked with the chemical symbols Hg (mercury), Cd (cadmium) and/or Pb (lead). Heavy metals can be harmful to the health of humans and animals and accumulate in the environment.

- In order to avoid these consequences, it is imperative to ensure you collect batteries separately and return them properly.

 Batteries for the remote control vehicle key and remote controls may contain perchlorate. For information on how to handle these materials correctly, see the following website: www.dtsc.ca.gov/perchlorate. Follow all the legal specifications for dealing with and disposing of these batteries. Volkswagen recommends having these batteries replaced and disposed of by suitably qualified professionals. Volkswagen recommends contacting an authorized Volkswagen dealer or authorized Volkswagen Service Facility.

Product recycling

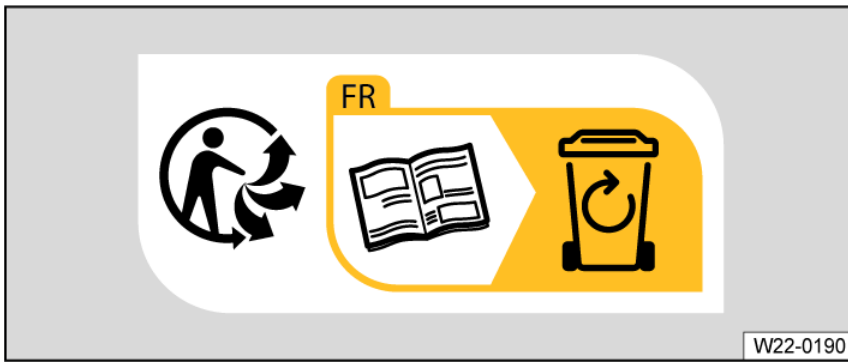

Fig. 202

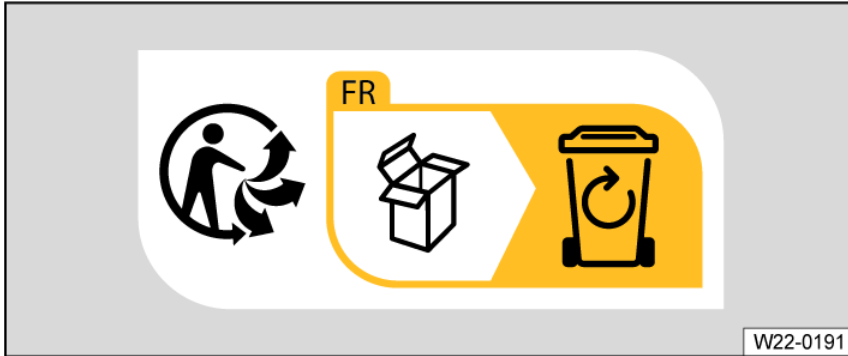

Fig. 203

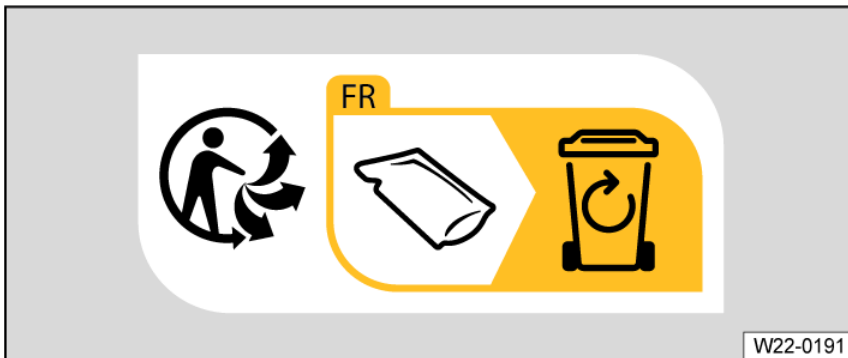



Fig. 204

 The Triman logo and the Infotri symbol contain important sorting information for the end consumer.

Declaration of conformity (Declaration of Compliance, Telecommunications and Electronic Systems)

Radio Frequency Devices and Radiocommunication Equipment User Manual Notice.

Radio equipment

- Provision for mobile telephone.
- Electronic immobilizer
- Remote start relay function
- Vehicle key
- Keyless locking and starting system Keyless Access.
- USA: VW Car-Net®.
- Adaptive Cruise Control (ACC)
- Autonomous Emergency Braking (Front Assist).
- Rear Traffic Alert.

These devices comply with:

FCC Part 15.19

These devices comply with **Part 15 of the FCC Rules**. Operation is subject to the following 2 conditions:

- (1) This device may not cause harmful interference, and

(2) this device must accept any interference received, including interference that may cause undesired operation

FCC Part 15.21

CAUTION:

Changes or modifications not expressly approved by the party responsible for compliance could void the user's authority to operate the equipment.

These devices comply with **RSS-210 of Industry Canada**.

Operation is subject to the following 2 conditions:

(1) This device may not cause interference, and

(2) this device must accept any interference, including interference that may cause undesired operation of the device.

The manufacturer is not responsible for any radio or TV interference caused by unauthorized modifications to this equipment.

Third Party Copyright Information

<http://www.volkswagen.com/softwareinfo>

Some products installed in this vehicle contain software components that are covered under Open Source licenses.

A list of the Open Source software components being used, including copyright information, the relevant Open Source license conditions, and those applicable license texts, are available at the website given above. The source code of specific Open Source software components can be requested from the vehicle manufacturer. The manufacturer will provide the source code in accordance with the relevant license conditions, whereby you will only be charged for the provision costs, e.g. delivery costs. The required information can be obtained at the website given above.

Old vehicle return and scrap disposal

Old vehicle return

At the end of its life cycle, your vehicle should be recycled or disposed of in an environmentally friendly manner. This is why the last owners of vehicles in many states are legally obliged to hand their vehicles over to an authorized treatment facility.

Volkswagen has already made provision for this point: Recycling centers where you can hand over your vehicle are available throughout many federal states.

Find out more information about recycling centers from your authorized Volkswagen dealer or authorized Volkswagen Service Facility.

Scrap disposal

If scrapping the vehicle or its individual parts such as the airbag system and the safety belt pretensioners, the applicable safety regulations must always be followed. Suitably qualified professionals will be familiar with these provisions. Volkswagen recommends contacting your authorized Volkswagen dealer or authorized Volkswagen Service Facility.

Radar sensors

Depending on the vehicle equipment, assistance systems e.g. Adaptive Cruise Control (ACC) (ACC) that use a radar sensor can be installed in your vehicle.

Observe the legal regulations for restricted access to certain zones that prohibit entry for vehicles with radar sensors. Observe relevant available traffic signs where applicable. If you want to drive into one of the regions, first contact an authorized Volkswagen dealer or authorized Volkswagen Service Facility to ask whether radar sensors are installed in your vehicle.

⚠ WARNING

Sensors can be subject to physical system limitations. External sources of interference, e.g. from other vehicles, can affect the functions of the sensors. The supporting systems may be restricted or may not work as expected.

Reporting Safety Defects

If you believe that your vehicle has a defect which could cause a crash or could cause injury or death, you should immediately inform the National Highway Traffic Safety Administration (NHTSA) in addition to notifying Volkswagen of America, Inc. 3800 Hamlin Road, Auburn Hills, MI 48326.

If NHTSA receives similar complaints, it may open an investigation, and if it finds that a safety defect exists in a group of vehicles, it may order a recall and remedy campaign. However, NHTSA cannot become involved in individual problems between you, your dealer, or Volkswagen of America, Inc.

To contact NHTSA, you may call the Vehicle Safety Hotline toll-free at:

Tel.: 1-888-327-4236 (TTY: 1-800-424-9153)

go to:

<http://www.nhtsa.gov>

or write to:

Administrator, NHTSA, 1200 New Jersey Avenue, SE, Washington, D.C. 20590

You can also obtain other information about motor vehicle safety from

<http://www.safercar.gov>

Notes on radio regulations



Declaration of conformity for radio equipment for the USA

Approval mark for radio systems in the USA.

With this document, the manufacturer declares that the radio equipment listed in the following is in compliance with the basic requirements and other relevant regulations and laws at the time of production:

The radio systems listed below are not available in every vehicle.

- Connection to the exterior antenna
- Antenna
- Antenna amplifier
- Bluetooth®.
- Remote control key (vehicle)
- Garage door opener
- ID. Cockpit.
- Infotainment system
- Keyless Access.
- Instrument cluster, electronic immobilizer
- Radar sensors for assistance systems
- Tire pressure sensors
- Mobile phone interface
- Volkswagen Car-Net control module
- Wi-Fi hotspot.
- Central control module

 **Radio systems with this marking must be collected separately from normal household garbage and disposed of in accordance with legal requirements**
 **Disposal of old batteries and electronic devices.**  **Symbol for limited use of certain hazardous substances in electrical and electronic devices in accordance with the RoHS directive.**

Approval numbers

FCC ID: 2AAJCBR20, FCC ID: 2AAJCBR21, FCC ID: 2AA98, FCC ID: 2AA98-COLOUR5C, FCC ID: 2AA98-MEDIUM5C, FCC ID: 2AA98-MEDIUM5C21, FCC ID: 2AA98A, FCC ID: 2AHPN-WLC, FCC ID: 2AOUZ17101001, FCC ID: 2AOUZ17101002, FCC ID: 2AOUZ17101010, FCC ID: 2AOUZ17101022, FCC ID: 2AOUZ17101023, FCC ID: 2AOUZ17101031, FCC ID: 2AOUZ17101032, FCC ID: 2AOUZ17101033, FCC ID: 2AOUZ17101034, FCC ID: 2AOUZ17101041, FCC ID: 2AOUZ17101042, FCC ID: 2AOUZ17101043, FCC ID: 2AOUZ17101051, FCC ID: 2AOUZ17101052, FCC ID: 2AOUZ17101053, FCC ID: 2AOUZ17101054, FCC ID: 2AOUZ17101055, FCC ID: 2AOUZ17101056, FCC ID: 2AOUZ17101057, FCC ID: 2AOUZ17101071, FCC ID: 2AOUZ17101072, FCC ID: 2AOUZ18020531, FCC ID: 2AOUZ18020532, FCC ID: 2AOUZ18020533, FCC ID: 2AOUZ18020534, FCC ID: 2AOUZ18100931, FCC ID: 2APOM-MQBA0, FCC ID: 2AVXWWSBRC001, FCC ID: 2AXPS-WPC003-1, FCC ID: 772C-LB1FD, FCC ID: BEJLCW05-VWE5, FCC ID: BEJMIB2, FCC ID: BEJMIB2PQ, FCC ID: BEJ-MEBICAS3, FCC ID: BEJ-MIBPQMIN, FCC ID: BEJ-MIB3OI, FCC ID: BEJTLAHW3IU-E, FCC ID: BEJTLAHW3IU-N, FCC ID: BEJTLVHE4IU-E, FCC ID: BEJTLVHE4IU-N, FCC ID: BEJTLVHM3IU-E, FCC ID: BEJTLVHM3IU-N, FCC ID: BEJTLVM3IU-N, FCC ID: BEJTUVM01IU, FCC ID: CWTUGZZF1, FCC ID: CWTUGZZF2, FCC ID: IYZVK2, FCC ID: KR5-BCMEVOC, FCC ID: KR5FS14T, FCC ID: KR5FS14TK, FCC ID: KR55NA920791A, FCC ID: LTQR3TR, FCC ID: NBG010180T, FCC ID: NBG010905A, FCC ID: NBG011719A, FCC ID: NBG013854, FCC ID: NBG01RS4, FCC ID: NBG011719A, FCC ID: NBG10176, FCC ID: NBG9068, FCC ID: NBG92596263, FCC ID: NBGBCMEVO, FCC ID: NBGBCMEVO5, FCC ID: NBGBCM2R, FCC ID: NBGFS09P03, FCC ID: NBGFS12A, FCC ID: NBGFS12A01, FCC ID: NBGFS12P, FCC ID: NBGFS12P01, FCC ID: NBGFS12PM, FCC ID: NBGFS12P01M, FCC ID: NBGFS125C, FCC ID: NBGFS125C1, FCC ID: NBGFS125C5, FCC ID: NBGFS173NP, FCC ID: NBGFS173NPM, FCC ID: NBGFS173NR, FCC ID: NBGFS1744M, FCC ID: NBGFS19, FCC ID: NBGFS191, FCC ID: NBGFS93N, FCC ID: NBGMQBBB, FCC ID: NBGMQBBH, FCC ID: NBGPQ12P01, FCC ID: NBGRSB19, FCC ID: NF3-FR5CPEC, FCC ID: NF3-LRR3SCU, FCC ID: NF3-LRR4, FCC ID: NF3-MRR1PLUS, FCC ID: NF3-MRR1REAR, FCC ID: NF3-MRREVO14F, FCC ID: NF3-LRR3SCU, FCC ID: NT8-FPK8IMMO5D, FCC ID: NT8-VWMIBREGIO, FCC ID: NZLADHL5D, FCC ID: NZLJCIBUSHL4, FCC ID: OAYARS4B, FCC ID: OAYARS5B, FCC ID: OYGTSSRE4UD, FCC ID: OYGTSSRE4UF, FCC ID: OYGTSSSG4G5, FCC ID: QIPALAS6A-US, FCC ID: QISME919BS-567BN, FCC ID: QISME919BS-567BNB, FCC ID: QZ9-KA3, FCC ID: RK7MBC-NAR, FCC ID: RK7MBC-NAR2, FCC ID: RK7185-00, FCC ID: RK7186-00, FCC ID: RX2BNFHL, FCC ID: RX2BNFLL, FCC ID: T8GA270, FCC ID: T8GA475, FCC ID: T8GA476, FCC ID: T8GP114, FCC ID: VPYLB1KD, FCC ID: WJLHT-5.

Interference statement

This device complies with part 15 of the FCC Rules. Operation is subject to the following two conditions:

- (1) This device may not cause harmful interference, and
- (2) This device must accept any interference received, including interference that may cause undesired operation.

CAUTION TO USERS: Changes or modifications not expressly approved by the party responsible for compliance could void the user's authority to operate the equipment.

FCC RF Exposure Statement

FCC ID: RK7MBC-NAR

This equipment complies with FCC radiation exposure limits set forth for an uncontrolled environment. End users must follow the specific operating instruction for satisfying RF exposure compliance. This transmitter must not be co-located or operating in conjunction with any other antenna or transmitter.

This is a CONSUMER device.

BEFORE USE, you MUST REGISTER THIS DEVICE with your wireless provider and have provider's consent. Most wireless providers consent to the use of signal boosters. Some providers may not consent to the use of this device on their network. If you are unsure, contact your provider.

You MUST operate this device with approved antennas and cables as specified by the manufacturer. Antennas MUST be installed at least 20 cm (8 inches) from any person.

You MUST cease operating this device immediately if requested by FCC or a licensed wireless service provider.

WARNING: E911 location information may not be provided or may be inaccurate for calls served by using this device.

Wireless notice

This device complies with FCC radiation exposure limits set forth for an uncontrolled environment and meets the FCC radio frequency (RF) Exposure Guidelines. This transmitter must not be colocated or operating in conjunction with any other antenna or transmitter. The antenna should be installed and operated with minimum distance of 20 cm between the radiator and your body.

FCC Class A digital device notice

NOTE: This equipment has been tested and found to comply with the limits for a Class A digital device, pursuant to part 15 of the FCC Rules. These limits are designed to provide reasonable protection against harmful interference when the equipment is operated in a commercial environment. This equipment generates, uses, and can radiate radio frequency energy and, if not installed and used in accordance with the instruction manual, may cause harmful interference to radio communications. Operation of this equipment in a residential area is likely to cause harmful interference in which case the user will be required to correct the interference at his own expense.

FCC Class B digital device notice

NOTE: This equipment has been tested and found to comply with the limits for a Class B digital device, pursuant to Part 15 of the FCC Rules. These limits are designed to provide reasonable protection against harmful interference in a residential installation. This equipment generates, uses and can radiate radio frequency energy and, if not installed and used in accordance with the instructions, may cause harmful interference to radio communications. However, there is no guarantee that interference will not occur in a particular installation. If this equipment does cause harmful interference to radio or television reception, which can be determined by turning the equipment off and on, the user is encouraged to try to correct the interference by one or more of the following measures:

- Reorient or relocate the receiving antenna.
- Increase the separation between the equipment and receiver.
- Connect the equipment into an outlet on a circuit different from that to which the receiver is connected.
- Consult the dealer or an experienced radio/TV technician for help.

Technical data

Information on technical data

General information about specifications

As long as nothing else is specified or listed, the technical data applies to the base model. Different values may result due to optional equipment, different model versions, special equipment, and market-specific equipment. The specifications in the legal vehicle documents always take precedence.

The drive and power of the vehicle are listed in the official vehicle registration.

Weight

The values for the curb weight in the following tables apply to a vehicle ready for operation with standard equipment, without a driver, with fluids including 100% full fuel tank. Optional equipment and retrofitted equipment will increase the specified curb weight and reduce the possible load.

The load consists of the following weight:

- Passengers.
- All luggage inside and outside the vehicle.
- Attachments.
- Trailer tongue weight if in trailer mode.

The permitted total vehicle weight and the gross axle weight rating must never be exceeded. The permissible values are indicated on the safety compliance label on the identification label on the B-pillar on the driver's side → [Safety certificate](#) → [Identification label](#).

Performance

The performance was determined without equipment that limits performance, such as add-on parts.

Due to technical or legal reasons, the performance specifications and mileage may vary.

On some engines with heavy duty suspension, the speed maximum speed may be limited and lower.

Towing weight and trailer tongue weight ratings

The towing weight and trailer tongue weight ratings on the trailer hitch identification label are simply the test values for the trailer hitch. The vehicle-based specifications, which are often below these values, can be found in your vehicle documents. The specifications in the official vehicle registration or on the identification label of the vehicle → [Identification label](#) or safety certificate → [Safety certificate](#) always take precedence.

Towing weight

The indicated combination weights apply only for altitudes up to 1000 m (3000 ft) above sea level. For every additional 1000 m (3000 ft), the gross combination weight rating must be reduced approximately 10%.

Incline angle

The incline angle is the specification up to which the vehicle is able to drive uphill on an angle with its own power. This can depend on the road conditions, the weather conditions, and the engine power, among other things. The values apply to a vehicle that is in motion and not to a vehicle that starts to drive from a stationary position.

A rising difference in altitude (incline) on a 100 m (300 ft) stretch is given in percentage or degrees (100% = 45 degrees).

Vehicle Identification Number (VIN)

Structure of the vehicle identification number (VIN)

The vehicle identification number (VIN, VIN) consists of 17 characters. These characters can be sorted into seven groups.

The structure is explained using the following examples of vehicle identification numbers.

Group	①			②			③		④	⑤	⑥	⑦					
Position	1	2	3	4	5	6	7	8	9	10	11	12	13	14	15	16	17
Example	W	V	W	Z	Z	Z	C	B	Z	M	E	4	0	0	9	5	3
	W	V	W	A	F	2	9	N	4	8	Y	0	0	0	0	0	1

① Vehicle manufacturer identification:

WVW Volkswagen Passenger Vehicles

WVG Volkswagen Passenger Vehicles

1VW	Volkswagen Group of America Inc., Volkswagen de México, S.A. de C.V
3VW	Volkswagen de México, S.A. de C.V
XW8	LLC Volkswagen Group Rus (Volkswagen/Skoda Kaluga)
MFB	Garuda Matraman Motor (Indonesia)

② Filler characters: The filler characters may vary depending on manufacturer, or contain information on the body shape and transmission type.

③ Vehicle class, depending on model:

3H	Arteon
5T	Touran
6R	Polo
AC	T-Roc convertible
BV	Golf
CB	Passat
CA	Atlas
CR	Touareg

Depending on the manufacturer, digits 7 to 9 can also contain information on the fuel type (7) and vehicle class (8 and 9).

④ Filler characters or check digits: The filler characters or check digits may vary depending on the manufacturer.

⑤ VIN index, depending on model year:

M	2021
N	2022
P	2023
R	2024

⑥ Production location, plant where the vehicle was manufactured:

C	Volkswagen plant in Chattanooga
D	Volkswagen plant in Bratislava
E	Volkswagen plant in Emden
K	Volkswagen plant in Osnabrück Or: Volkswagen plant in Kaluga
M	Volkswagen plant in Puebla
P	Volkswagen plant in Zwickau
T	Volkswagen plant in Pune
U	Volkswagen plant in Uitenhage
V	Volkswagen plant in Palmela
W	Volkswagen plant in Wolfsburg
Y	Volkswagen plant in Pamplona

The letter assignment for the production site may vary depending on the vehicle or be assigned twice.

⑦ Sequential production number for each model year.

Position of the vehicle identification number



Fig. 205 In the windshield: vehicle identification number (VIN)

The VIN can be read from the outside through the viewing window in the windshield. The viewing window is at the side of the lower section of the windshield. In some models, it may be possible to display the VIN in the Service menu or in the vehicle settings, depending on the Infotainment system. The vehicle identification number may also be located on the identification label.

The VIN may also be stamped in the following locations, depending on the model, market, and engine:

- In the right water drain channel in the engine/motor compartment
- On the right suspension strut tower in the engine/motor compartment
- In the engine compartment near the hinge for the hood on the right side of the vehicle.
- Under the carpet behind the right front seat

Identification label

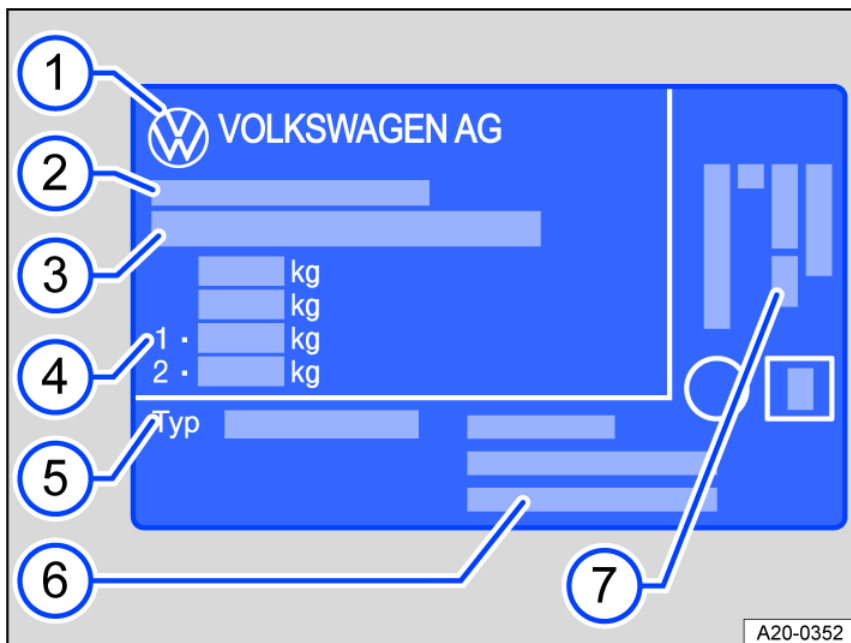

Fig. 206 Identification label (general example): version 1.

Depending on the country, the type approval number, such as the EU operating license, may be specified.

- ① Manufacturer code.
- ② Type approval.
- ③ Vehicle Identification number.
- ④ Gross Vehicle Weight Rating.
Gross combination weight rating (towing vehicle and trailer).
Front Gross Axle Weight Rating.
Rear Gross Axle Weight Rating.
- ⑤ Vehicle model
- ⑥ Manufacturer's address.
- ⑦ Engine code.

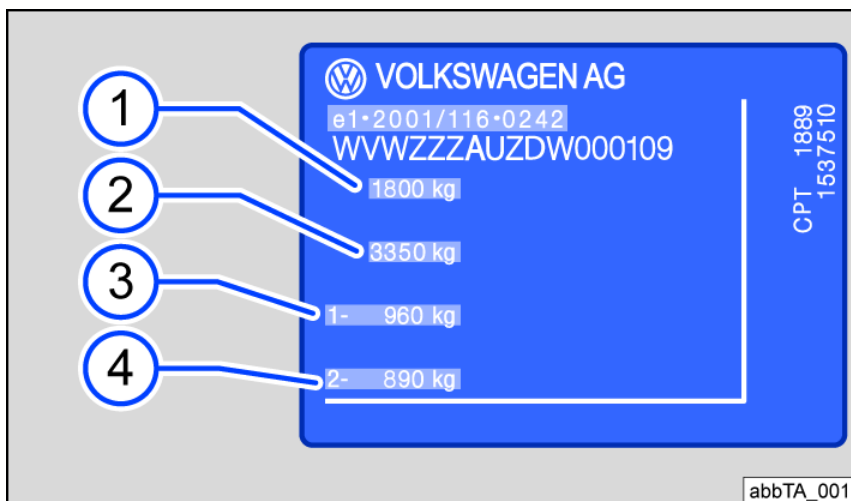

Fig. 207 Identification label (general example): version 2.

Depending on the country, the type approval number, such as the EU operating license, may be specified.

- ① Gross Vehicle Weight Rating.
- ② Gross combination weight rating (towing vehicle and trailer).
- ③ Front Gross Axle Weight Rating.
- ④ Rear Gross Axle Weight Rating.

Depending on the country and model, the model plate may be visible in the lower section of the door pillar when the driver's or front passenger door is open. Vehicles exported to some countries do not have a model plate.

Safety certificate

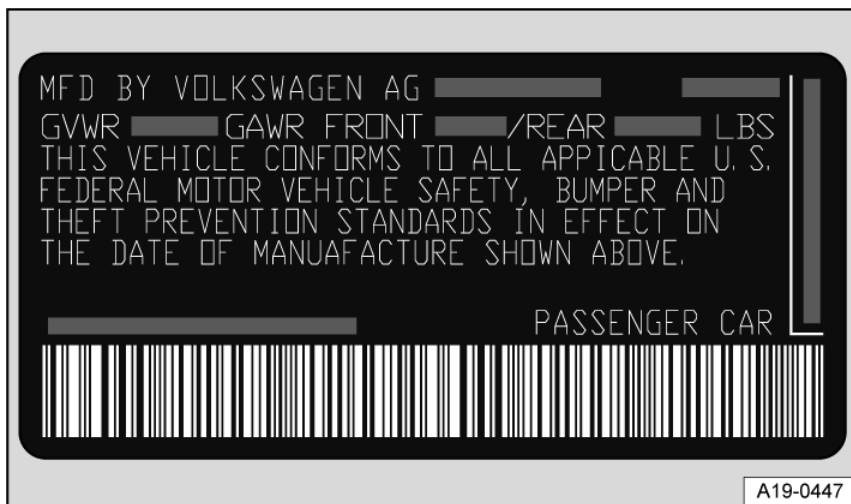

Fig. 208 Safety certificate (general example).

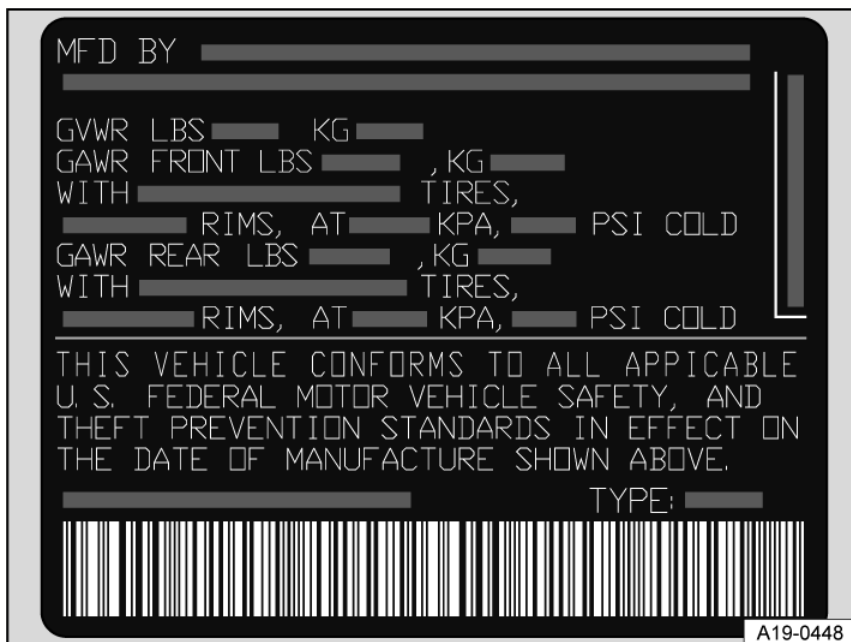
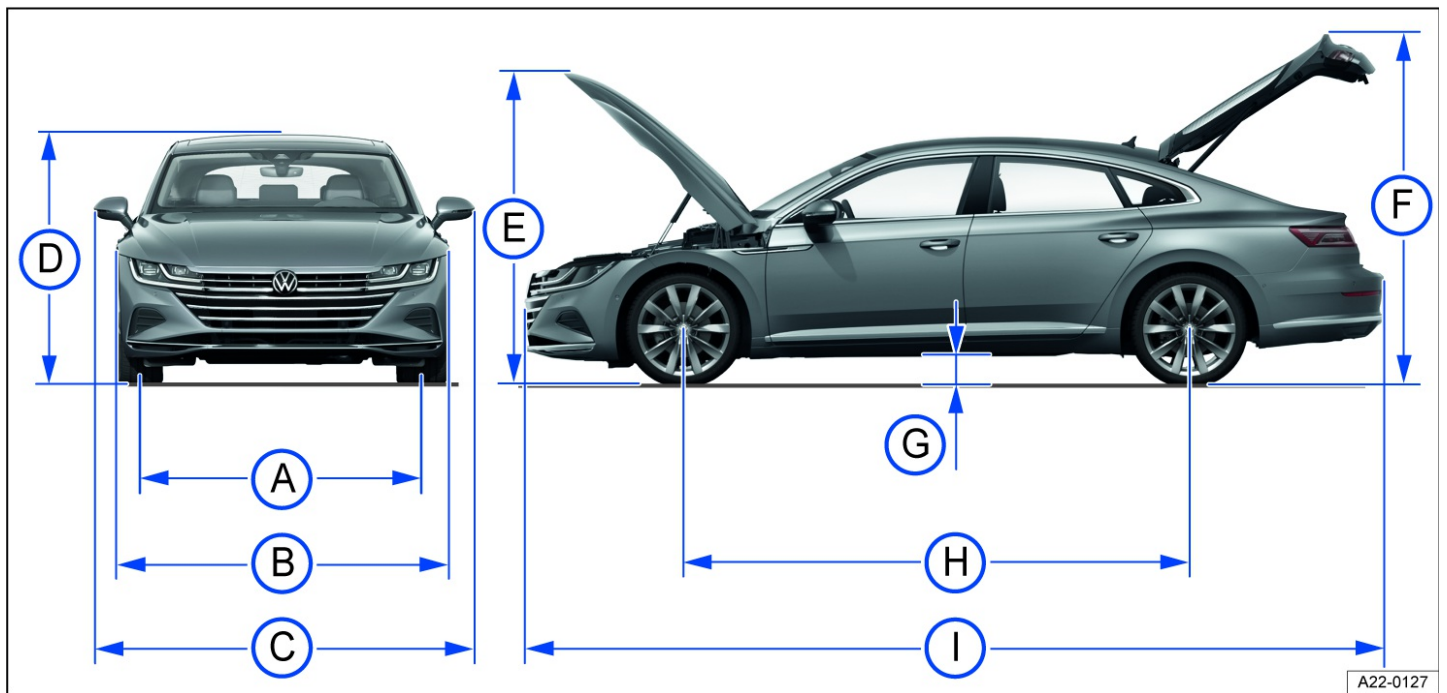

Fig. 209 Safety certificate (general example).

A safety certificate on the driver door pillar displays the following information:

- Manufacturer.
- Country of manufacture.
- Date of manufacture.
- Gross vehicle weight rating.
- Gross axle weight ratings.
- Tire size.
- Rim size
- Tire pressure.
- Vehicle Identification number.
- Type designation.

Dimensions



A22-0127

Fig. 210 Vehicle dimensions.

The information in the table applies for the standard model with standard equipment.

In the case of other rim and wheel sizes, additional equipment, different model versions and the retrofitting of accessories as well as in the case of special vehicles, these values may differ.

Information about how the weight specifications are compiled can be found in section [⇒ General information about specifications](#).

Where the vehicle dimensions are not given, the values were not available at the time of printing.

Key for <i>fig. 210</i> :			
A	Front track	mm (in)	1 5 8 7 (6 2 .5)
	Rear track	mm (in)	1 5 7 7 (6 2 .1)
B	Width	mm (in)	1 8 7 1 (7 3 .7)

Key for <i>fig. 210</i> :			
Ⓒ	Width from outside mirror to outside mirror (outside mirror folded in)	mm (in)	1 9 2 4 (7 5 · 7)
Ⓓ	Height at curb weight to top of the roof	mm (in)	1 4 2 6 (5 6 · 1)
	Height with curb weight with navigation antenna	mm (in)	1 4 4 2 (5 6 · 8)
Ⓔ	Height with open hood and at curb weight	mm (in)	1 8 6 8 (7 3 · 5)
Ⓕ	Height with open trunk lid and at curb weight	mm (in)	2 1 7 0 (8 5 · 4)
Ⓖ	Ground clearance at curb weight between the axles	mm (in)	1 3 8 (5 · 4)

Key for <i>fig. 210</i> :			
H	Wheelbase with curb weight	mm (in)	2 8 4 1 (1 1 1 .9)
	Minimum turning circle diameter	m (ft)	1 1 .9 (3 9 .0)
I	Length from bumper to bumper	mm (in)	4 8 6 6 (1 9 1 .6)

Tank capacities

The fuel tank has the following volume:

- 17.4 gallons (approximately 66 l)

 The capacity of the fuel tank includes an indeterminate reserve quantity that remains in the fuel tank when the fuel gauge shows that the fuel tank is empty. The reserve quantity is variable and cannot reliably serve to increase the remaining range.

Gasoline engines

2.0 l, 4 cylinder, TFSI®, 224 kW (300 hp), gasoline engine

Engine overview

Output	kW	224 at 5350 – 6500 rpm
	hp	300 at 5350 – 6500 rpm
Engine code	DSFB	
Maximum torque	Nm	400 at 2000 – 5350 rpm
	ft-lb	295 at 2000 – 5350 rpm

Transmission		DSG [®] 7	DSG [®] 74 MOTION
Maximum speed	km/h	-	-
	mph	-	-

Weight specifications and axle loads

Transmission		DSG [®] 7	DSG [®] 74 MOTION
Curb weight	kg	1668	1782
	lbs	3677	3929
Gross Vehicle Weight Rating	kg	2140	2280
	lbs	4718	5027
Front Gross Axle Weight Rating	kg	1130	1170
	lbs	2491	2579
Rear Gross Axle Weight Rating	kg	1060	1160
			0

	lbs	2337	2 5 5 7
--	-----	------	------------------

Towing weights

Transmission		DSG [®] 7	D S G [®] 7 4 M O T I O N
Braked towing weight	kg	907	9 0 7
	lbs	2000	2 0 0 0
Unbraked towing weight	kg	748	7 4 8
	lbs	1650	1 6 5 0
Maximum gross combination weight rating	kg	3034	3 1 8 4
	lbs	6710	7 0 2 0
Maximum permissible trailer tongue weight rating	kg	91	9 1
	lbs	200	2 0 0

⁴⁾ This data was not available at the time of printing.

Abbreviations used

Abbreviation Meaning