

Owner's Manual supplement for EyeSight system

SUBARU BRZ

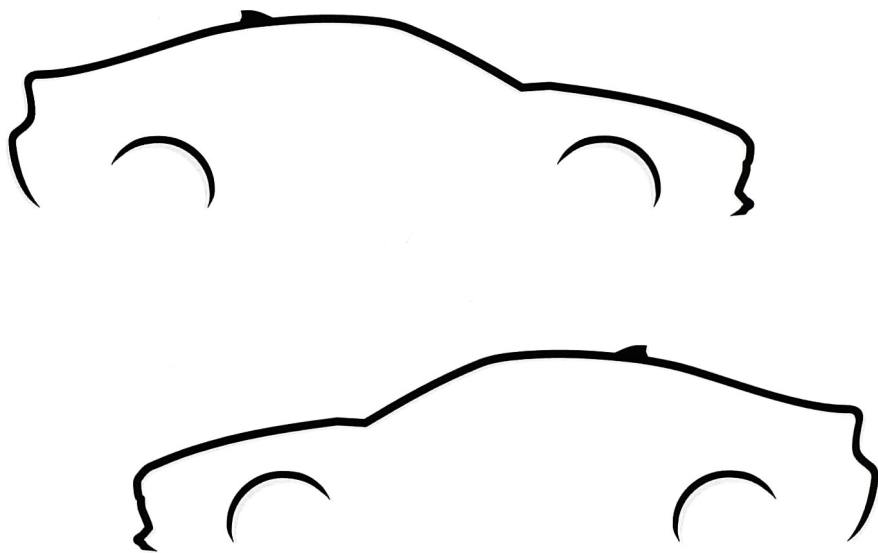

The Owner's Manual and/or supplementary documents below are specific to the Vehicle Identification Number (VIN) entered. Please read the Owner's Manual and/or supplementary documents carefully and always observe all warnings and cautions. As the Owner's Manual and supplementary documents are intended to cover several variants of the same model, certain content may pertain to equipment or features not installed on your vehicle. The Owner's Manual and supplementary documents are copyright © protected in favour of Subaru Corporation, Japan and must not be downloaded, reproduced, republished, and/or used without prior written consent, other than for personal use by you. By downloading the Owner's Manual and/or supplementary documents you agree to the foregoing.



SUBARU
B4632AE-A

Foreword

Congratulations on choosing a SUBARU vehicle equipped with EyeSight™. EyeSight incorporates the latest driver assistance features available from SUBARU, including such features as Adaptive Cruise Control, a Lead Vehicle Start Alert and a Lane Departure and Lane Sway Warning, all of which are designed to assist the driver in making decisions and increase driver comfort and convenience. Initially, the operation and use of the various EyeSight features may be unfamiliar to you. That is why we urge you to read this manual carefully before using EyeSight. We also recommend that you first take the time to test EyeSight in order to experience its features for yourself so that you can become familiar with their operation.

Please keep in mind that it is the responsibility of drivers to operate their vehicles safely at all times. Drivers should always remain alert and should never become complacent while operating their vehicles because of the presence of EyeSight. EyeSight is never a substitute for active driver involvement and it may not operate optimally under all driving conditions.

This booklet is a supplement to the Owner's Manual for your SUBARU vehicle and contains a detailed description of EyeSight. It should be read in conjunction with your Owner's Manual so that you will gain a thorough understanding of the proper operation of your vehicle.

The information, specifications and illustrations found in this booklet are those in effect at the time of printing. SUBARU CORPORATION reserves the right to change specifications and designs at any time without prior notice and without incurring any obligation to make the same or similar changes on vehicles previously sold.

Please keep this booklet together with your Owner's Manual and leave it in the vehicle at the time of resale. The next owner will need the information it contains.

SUBARU CORPORATION, TOKYO, JAPAN

"SUBARU" and the six-star cluster design are registered trademarks of SUBARU CORPORATION.

© Copyright 2024 SUBARU CORPORATION

EyeSight

About EyeSight	4
Pre-Collision Braking System.....	24
Adaptive Cruise Control	39
Pre-Collision Throttle Management (AT models).....	67
Lane Departure Warning	74
Lane Sway Warning	78
Lead Vehicle Start Alert	82
Conventional Cruise Control	84
List of alert/notification sounds.....	100
EyeSight malfunction and temporary stop	101
Changing settings	105
Message screen list	109
Troubleshooting	112

About EyeSight

EyeSight is a driving support system that uses a range of functions to assist the driver in making decisions in order to provide for more safe and comfortable driving and to reduce driver fatigue. Making use of images created by the stereo camera specially designed by SUBARU, EyeSight detects the vehicle in front, obstacles, traffic lanes and other items.



WARNING

Drivers are responsible for driving safely. Always comply with all traffic rules and regulations regardless of the fact that your vehicle is equipped with EyeSight. Always maintain a safe following distance between your vehicle and the vehicle in front of you, pay attention to your surroundings and driving conditions, and take necessary actions in order to maintain a safe following distance.

Never attempt to drive relying on EyeSight alone.

EyeSight is intended to assist the driver in making decisions in order to reduce the risk of accidents or damage and lessen the burden on the driver.

When an EyeSight warning is activated, pay attention to what is in front of you and to your surroundings, and take necessary actions.

This system is not designed to support driving in poor visibility or in extreme weather conditions, or to protect against careless driving when the driver is not paying complete attention to the road ahead. It also cannot prevent collisions from occurring in all driving conditions.

There are limits to the EyeSight recognition performance and control performance. Be sure to read the instructions for each function before using the system, and always use it properly. Improper use may lead to failure of control performance, which could cause an accident.

Refer to the following pages for each function:

- For Pre-Collision Braking System, refer to page 24.
- For Adaptive Cruise Control, refer to page 39.
- For Pre-Collision Throttle Management, refer to page 67.
- For Lane Departure Warning, refer to page 74.
- For Lane Sway Warning, refer to page 78.
- For Lead Vehicle Start Alert, refer to page 82.
- For Conventional Cruise Control, refer to page 84.

In right-hand drive vehicles, EyeSight is configured for driving on the left-hand side of the road. However, it can be reconfigured by changing the Driving Lane Customize setting for driving on the right-hand side.*

⇒ **Page 105**

If the setting for the traffic lane (driving side of the road) does not match the traffic lane, full EyeSight performance may not be available.

***: Characteristics and settings that are affected by specific differences between right-hand drive and left-hand drive vehicles cannot be changed.**

- The system may not operate correctly under the conditions listed below. When these conditions occur, turn off Pre-Collision Braking System. Also, do not use Adaptive Cruise Control or Conventional Cruise Control.
 - The tire pressure is not correct.*¹
 - The temporary spare tire is installed.*¹
 - Tires that are unevenly worn or tires with uneven wear patterns are installed.*¹
 - Tires that are the wrong size are installed.*¹
 - A flat tire has been fixed temporarily with a tire repair kit.
 - The suspension has been modified (including a genuine SUBARU suspension that has been modified).
 - An object that obstructs the stereo camera's view is installed on the vehicle.
 - Tire chains are installed.
 - The headlights are dirty or they have snow and ice or dirt on them. (Objects are not correctly illuminated and are difficult to detect.)
 - The optical axes are not aligned correctly. (Objects are not correctly illuminated and are difficult to detect.)
 - The lights including headlights and fog lights have been modified.
 - Vehicle operation has become unstable due to an accident or malfunction.
 - The brake system warning light (red) is illuminated.*²
 - A heavy cargo is inside the vehicle.
 - The maximum number of occupants is exceeded.
 - The combination meter is not operating properly; such as when the lights do not illuminate, the beeps do not sound, the display is different from when it is normal, etc.*³

Continued on next page ⇒

⇒ Continued from previous page

- The system will not operate correctly in the following conditions. Do not use Adaptive Cruise Control or Conventional Cruise Control.
 - The wheels are out of balance (e.g., the balance weight is removed or misaligned).^{*1}
 - The wheels are out of alignment.^{*1}
 - A trailer or another vehicle, etc. is being towed.

^{*1}: The wheels and tires have functions that are critically important. Be sure to use the correct ones. For details, refer to the vehicle Owner's Manual.

^{*2}: If the brake system warning light (red) does not turn off, immediately pull the vehicle over in a safe place and contact a SUBARU dealer to have the system inspected. For details, refer to the vehicle Owner's Manual.

^{*3}: For details about the combination meter, refer to the vehicle Owner's Manual.



- The characteristics of the stereo camera are similar to those of human eyes. For this reason, conditions that make it difficult for the driver to see in the forward direction have the same effect on the stereo camera. They also make it difficult for the system to detect vehicles, obstacles, and traffic lanes.
- Detection by the EyeSight system is limited to objects that are within the range of the stereo camera's field of view. Also, after an object enters the range of the camera's field of view, it may take some time for the system to detect it as a target obstacle and to warn the driver.

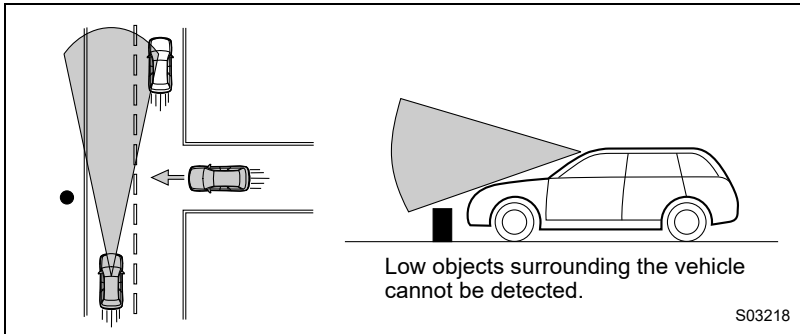

- Under the conditions listed below, it will become more difficult for the system to detect the vehicle in front, motorcycles, bicycles, pedestrians and obstacles on the road, and lane markers. Also, EyeSight may temporarily stop operating. However, the temporary stop will be canceled once these conditions have improved and the vehicle is driven for a short period of time.
 - Bad weather (for example heavy rain, a blizzard or thick fog). In particular, the system is more likely to temporarily stop operating when there is an oil film adhering to the windshield, a glass coating has been applied, or poorly performing wipers are used.
 - Strong light is coming from the front (sunlight or headlight beams of oncoming traffic, etc.).
 - The windshield washer is in use.
 - Raindrops, water drops, or dirt on the windshield are not wiped off sufficiently.
 - The stereo camera's field of view is obstructed by fogging, snow, dirt, frost, dust, scratches, or smears on the windshield, or by light reflecting off the dirt, etc.

Continued on next page ⇒

⇒ Continued from previous page

- The vehicle is tilted at an extreme angle due to loaded cargo or other factors.
- Visibility is poor due to sand, smoke or water vapor blowing in the wind, or the front vision is obscured due to water splashes, snow, dirt or dust stir up generated by the vehicle in front or oncoming traffic.
- The stereo camera's field of view is obstructed.
- Through the entrance or exit of a tunnel
- The rear aspect of the vehicle in front is low, small or irregular (for example a low bed trailer, etc.).
- The obstacle is a fence, a wall or a shutter, etc. with a uniform pattern (a striped pattern, brick, etc.) or with no pattern in front.
- The obstacle is a wall or door made of glass or a mirror in front.
- Driving at night or in a tunnel when there is a vehicle in front that does not have its taillights on
- Driving through a banner or flag, low branches on a tree or thick/tall vegetation
- On steep uphill or downhill grades
- The stereo camera is obstructed by a hand, etc. (If even one of the lenses is obstructed, the system does not operate properly.)
- It is completely dark and no objects are detected.
- The area around the vehicle has a uniform color (such as when completely covered in snow, etc.).
- Accurate detection is not possible due to reflections in the windshield.
- Under the conditions listed below, EyeSight may temporarily stop operating. If this occurs, EyeSight will resume operating when the conditions improve.
 - The temperature inside the vehicle is high, such as after the vehicle was left in bright sunshine, or the temperature inside the vehicle is low, such as after the vehicle was left in an extremely cold environment.
 - Immediately after the engine starts
- Under the conditions listed below, it is difficult to recognize vehicles in front, motorcycles, pedestrians, obstacles on the road, traffic lanes, etc. Also, the EyeSight system may temporarily stop operating. If the EyeSight system repeatedly stops operating several times, contact a SUBARU dealer and have the system inspected.
 - The stereo camera lenses are smeared such as from fingerprints.
 - The stereo camera has become misaligned due to a strong impact.

- When there is a malfunction in the EyeSight system, turn off Pre-Collision Braking System (⇒ page 37) and Lane Departure Warning (⇒ page 76), and stop using Adaptive Cruise Control and Conventional Cruise Control. Contact a SUBARU dealer and have the system inspected.
- When the Vehicle Stability Control (VSC) warning light is illuminated, Pre-Collision Braking System may not operate properly. If the warning light is illuminated, turn off Pre-Collision Braking System. Also, do not use Adaptive Cruise Control or Conventional Cruise Control.



NOTE

- EyeSight records and stores the following data when Pre-Collision Braking System is operated. It does not record conversations or other audio data.
 - Stereo camera image data
 - Distance from the vehicle in front
 - Vehicle speed
 - Steering wheel turning angle
 - Lateral movement with regards to the direction of travel
 - Accelerator pedal operation status
 - Brake pedal operation status
 - Clutch pedal operation status (MT models)
 - Select lever position (AT models)
 - Shift lever position (MT models)
 - Odometer reading
 - Data related to ABS, Vehicle Stability Control (VSC) and TRC system
- SUBARU and third parties contracted by SUBARU may acquire and use the recorded data for the purpose of vehicle research and development. SUBARU and third parties contracted by SUBARU will not disclose or provide the acquired data to any other third party except under the following conditions.
 - With the consent of the vehicle owner or with the consent of the lessee if the vehicle is leased.
 - The disclosure/provision is based on a court order or other legally enforceable request.
 - Data that has been modified so that the user and vehicle cannot be identified is provided to a research institution for statistical processing or similar purposes.

Handling of the Stereo Camera

The stereo camera is located on the front map lights unit.

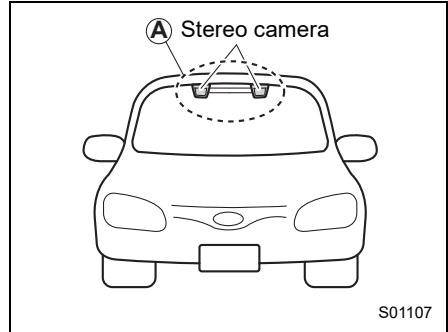

CAUTION

- The stereo camera monitors and detects smears or blurs on the front of the camera. However, detection is not 100% accurate. Under certain conditions, the function may fail to detect smears or blurs on the front of the stereo camera accurately. In addition, this function may not detect that there is snow or ice on the windshield close to the stereo camera. In such conditions, be sure to keep the windshield clean at all times (indicated by ). Otherwise the system may not operate correctly. When this function detects that the front of the stereo camera is smeared or blurred, no EyeSight functions can be activated except for Conventional Cruise Control.
- The stereo camera lenses are precision components. Always observe the following precautions especially when handling them.
 - Never touch the stereo camera lenses, and do not attempt to wipe or clean the lenses. Doing so could damage or soil the lens, and lead to improper system performance.If you ever touch a lens for any reason, be sure to contact a SUBARU dealer.

- When cleaning the windshield, cover the front of the camera casing with paper that does not collect dust, such as copy paper. Affix the paper to prevent glass cleaner from getting on the camera lenses. At this point, make sure that the tape's adhesive surface does not come in contact with the windshield or the lens. Be sure to remove the paper after cleaning.

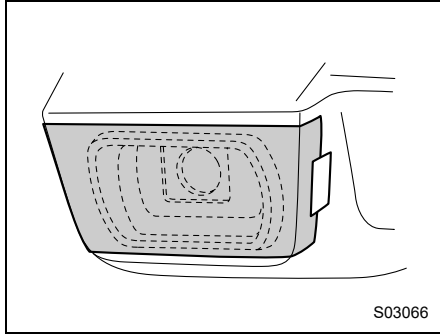

- When having the inside of windshield cleaned at a service station, etc., be sure to request that the attendant covers the camera covers before washing the vehicle.
- Do not subject the stereo camera to a strong impact.
- Do not remove or disassemble the stereo camera.
- Do not change the positions where the stereo camera is installed or modify any of the surrounding structures.
- Do not install an interior rearview mirror other than a genuine SUBARU rearview mirror (such as a wide-type mirror) and the sun visor. Also, use the rearview mirror so that it does not obstruct the stereo camera. Failure to do so may affect the stereo camera's field of view and could prevent the EyeSight system from functioning properly.

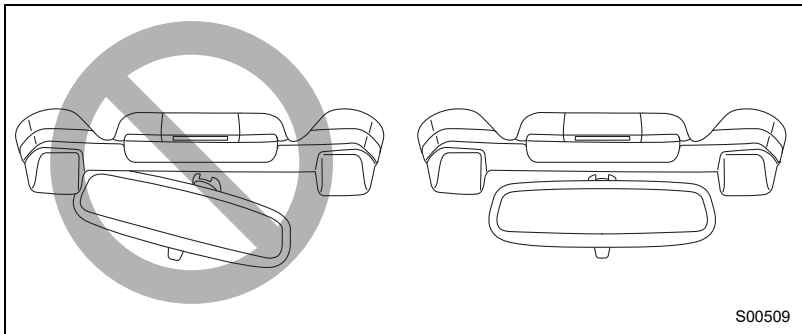

Continued on next page ⇒

⇒ Continued from previous page

- Do not install any accessories other than the ones designated by SUBARU on the prohibited areas shown in the illustrations (gray zones). Even if some accessories are installed on the outside of the prohibited areas, abnormal operation of EyeSight may occur due to the reflection of the light or any objects. In this situation, move the accessories. For details, contact a SUBARU dealer.

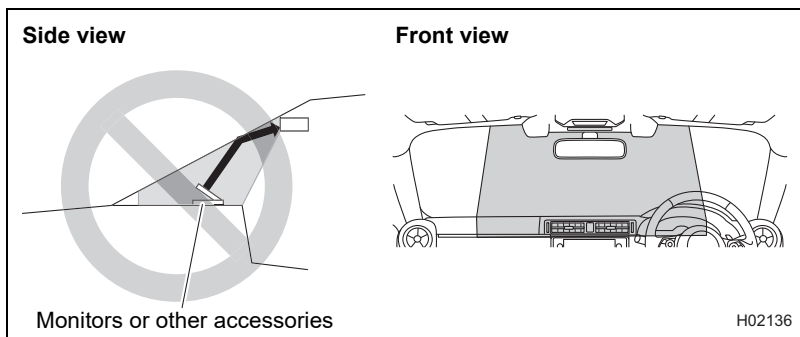

- Do not place any objects on top of the instrument panel. The stereo camera may not be able to detect objects accurately and the EyeSight system may not function properly due to reflections in the windshield. For details, contact a SUBARU dealer.
- If the top of the instrument panel is polished with chemicals or other substances, the stereo camera may not be able to detect objects accurately and the EyeSight system may not operate properly due to reflections in the windshield.
- Do not install any wiper blades other than genuine SUBARU wiper blades. Doing so may affect the stereo camera's field of view and could prevent the EyeSight system from functioning properly.
- Replace damaged wiper blades or worn wiper blade rubbers as soon as possible. Using damaged wiper blades or worn wiper blade rubbers may cause streaking on the windshield. The stereo camera may not be able to detect objects accurately and the EyeSight system may not function properly due to streaks or droplets remaining on the windshield.

- Do not install any accessories on the front side such as on the hood or the grille. It may affect the camera view and the system may not operate correctly.
- Make sure that the stereo camera's field of view is not interfered. Obstructing the stereo camera's view may impair the system operation. For details, contact a SUBARU dealer.
- Keep the windshield (outside and inside) clean at all times. When the windshield has become fogged, or it has a dirt or an oil film on it, the stereo camera may not detect objects accurately and the EyeSight system may not operate correctly. Never mount any device to the center air vent, as any airflow change may impact EyeSight performance.
- Do not place any stickers or accessories on the windshield (outside or inside). If you have to do so (for example, legally required or electronic toll tag), avoid the area directly in front of the camera. Otherwise, it may adversely affect the field of view of the stereo camera and can cause improper operation of the system. For details, contact a SUBARU dealer.
- Do not use any glass coating agents or similar substances on the windshield. Doing so may interfere with the proper operation of the system.
- Do not install any film or an additional layer of glass on the windshield. The system may not operate correctly.
- If there are scratches or cracks on the windshield, contact a SUBARU dealer.
- To have the windshield replaced or repaired, contact a SUBARU dealer. Do not install a windshield other than a genuine SUBARU windshield. The stereo camera may not be able to detect objects accurately and the EyeSight system may not operate properly.

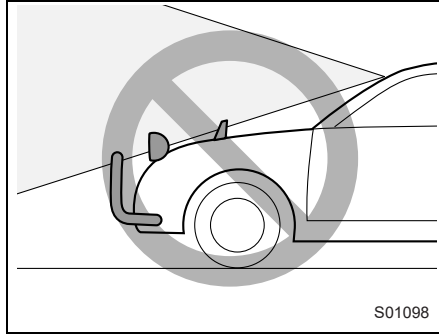

EyeSight Functions

EyeSight includes the following functions.

■ Pre-Collision Braking System

This function uses a following distance warning feature to warn the driver to take evasive action when there is a possibility of a collision with a vehicle, pedestrian or obstacle in front of you. If the driver does not take evasive action, the brakes are applied automatically to help reduce vehicle collision damage or, if possible, help prevent a collision.

⇒ Page 24

■ Adaptive Cruise Control

This function maintains a set vehicle speed that is manually set by the driver. When there is a vehicle in front in the same traffic lane, your vehicle follows the vehicle in front up to the set vehicle speed.

⇒ Page 39

■ Pre-Collision Throttle Management (AT models)

This function reduces accidental forward movement caused by the select lever being placed in the wrong position or the accelerator pedal being accidentally depressed, or depressed too strongly.

⇒ Page 67

■ Lane Departure Warning

This function warns the driver when the vehicle is about to drift off the road.

⇒ Page 74

■ Lane Sway Warning

This function warns the driver when the system detects that the vehicle is swaying in the lane, caused by driver fatigue, failure to concentrate on the road, inattention, strong crosswinds or other factors.

⇒ Page 78

■ Lead Vehicle Start Alert

This function notifies the driver when the vehicle stopped in front starts moving but the driver's vehicle remains stationary.

⇒ Page 82

■ Conventional Cruise Control

This function maintains a set vehicle speed that is manually set by the driver. It does not follow the vehicle in front. This function can be used even when the EyeSight system has temporarily stopped operating (⇒ page 103). This function is used by switching from Adaptive Cruise Control to Conventional Cruise Control.

⇒ Page 84









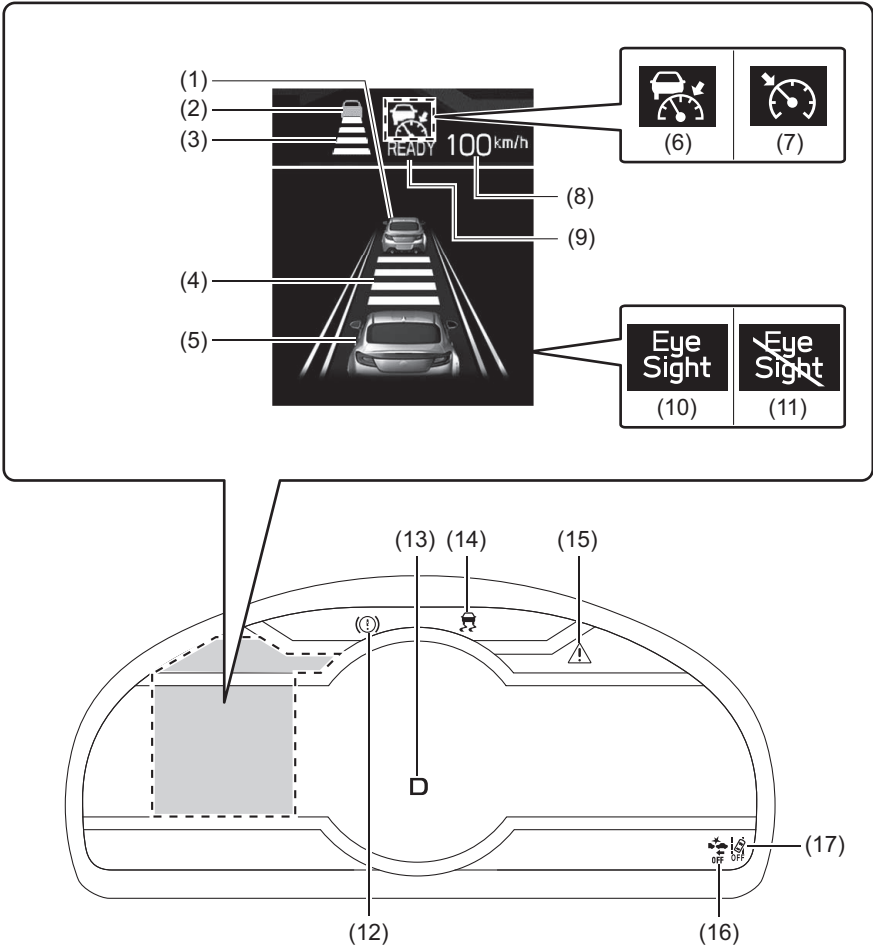

NOTE





EyeSight does not operate when the engine is not running.





Combination meter



H01050

(1)		<p>Lead vehicle indicator</p> <ul style="list-style-type: none"> • This indicator illuminates when a vehicle in front has been detected while Adaptive Cruise Control is active.
(2)		<ul style="list-style-type: none"> • When the meter information screen is set to display content other than the EyeSight screen, this indicator is shown as an icon. <p>⇒ Page 46</p>
(3)		<p>Following distance setting indicator</p> <ul style="list-style-type: none"> • This indicator shows the following distance setting that was set with the  (Following distance setting) switch.
(4)		<ul style="list-style-type: none"> • When the meter information screen is set to display content other than the EyeSight screen, this indicator is shown as an icon. <p>⇒ Page 57</p>
(5)		<p>Your vehicle indicator</p> <p>The brake lights on this indicator illuminate in red according to the actual brake control.</p>
(6)		<p>Adaptive Cruise Control indicator</p> <ul style="list-style-type: none"> • This indicator illuminates when the ON-OFF switch is pressed. ⇒ Page 46 • When Adaptive Cruise Control is activated, this indicator changes from white to green. When the driver accelerates the vehicle by depressing the accelerator pedal while Adaptive Cruise Control is operating, the indicator changes from green to white. ⇒ Page 46
(7)		<p>Conventional Cruise Control indicator</p> <ul style="list-style-type: none"> • This indicator illuminates when the  (Following distance setting) switch is pressed and held after pressing the ON-OFF switch. ⇒ Page 86 • When Conventional Cruise Control is activated, this indicator changes from white to green. ⇒ Page 86
(8)		<p>Set vehicle speed</p> <p>Displays the set vehicle speed. ⇒ Pages 46 and 86</p>





(9)		<p>READY indicator</p> <p>This indicator illuminates when cruise control* can be activated. ⇒ Pages 46 and 86</p> <p>*: Adaptive Cruise Control and Conventional Cruise Control</p>
(10)		<p>EyeSight warning indicator (yellow)</p> <ul style="list-style-type: none"> • This indicator illuminates or blinks when a malfunction occurs in the EyeSight system. • When it is illuminated or blinking, none of the EyeSight functions can be used (including Pre-Collision Braking System and Adaptive Cruise Control, etc.). <p>⇒ Page 101</p>
(11)		<p>EyeSight temporary stop indicator (white)</p> <ul style="list-style-type: none"> • When the ignition switch is turned to the ON position, this indicator will illuminate if the ON-OFF switch of cruise control is pressed just after the engine starts. It turns off several seconds after the engine starts. • It illuminates when the EyeSight system is temporarily stopped. • When it is illuminated, none of the EyeSight functions can be used except for Conventional Cruise Control. <p>⇒ Page 103</p>
(12)		<p>Brake system warning light (red)</p> <p>The brake system warning light (red) illuminates when:</p> <ul style="list-style-type: none"> • There is a malfunction in the brake system. • The parking lever is pulled up. • The brake fluid level is low. <p>The EyeSight system will not operate when the brake system warning light (red) is on due to the parking brake lever being pulled up or a malfunction in the brake system.</p> <p>It may operate when the brake system warning light (red) is on due to a low brake fluid level, however there may be insufficient braking force.</p> <p>If the brake system warning light (red) does not turn off, immediately pull the vehicle over in a safe place and contact a SUBARU dealer to have the system inspected.</p> <p>⇒ Refer to the vehicle Owner's Manual for details.</p>

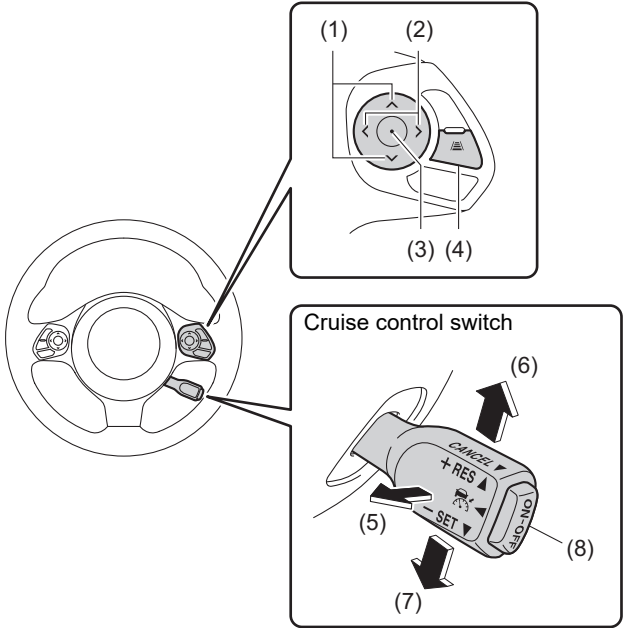

(13)		<p>AT models: Select lever/gear position indicator This indicator shows which position the select lever or the gear is in.</p> <p>MT models: Gear position indicator This indicator shows the position of the shift lever.</p>
(14)		<p>Vehicle Stability Control (VSC) warning light/Vehicle Stability Control (VSC) operation indicator light</p> <ul style="list-style-type: none"> • This warning light illuminates when the Vehicle Stability Control (VSC) system is probably malfunctioning. • This indicator light blinks during activation of the skid suppression function and during activation of the TRC system. <p>⇒ Refer to the vehicle Owner's Manual for details.</p>
(15)		<p>Master warning light</p> <p>This warning light illuminates when the master warning system has detected a malfunction.</p>
(16)		<p>Pre-Collision Braking System OFF indicator light</p> <ul style="list-style-type: none"> • This indicator light illuminates when the ignition switch is turned to the ON position, and then turns off several seconds after the engine starts. • AT models: It illuminates when Pre-Collision Braking System and Pre-Collision Throttle Management are off. ⇒ Pages 38 and 73 • MT models: It illuminates when Pre-Collision Braking System is off. ⇒ Page 38
(17)		<p>Lane Departure Warning OFF indicator light</p> <ul style="list-style-type: none"> • This indicator light illuminates when the ignition switch is turned to the ON position, and then several seconds after the engine starts, it turns off or remains illuminated depending on the current status (on or off). • It illuminates when Lane Departure Warning and Lane Sway Warning are off. <p>⇒ Pages 77 and 81</p>

Steering wheel



H01049

(1)		<p>^ / v switch</p> <p>Press one of these switches to change displayed content, scroll up/down the screen and move the cursor up/down.</p>
(2)		<p>< / > switch</p> <p>Press one of these switches to select menu icon.</p>
(3)		<p>⊙ switch</p> <ul style="list-style-type: none"> • Press this switch to confirm a selection. • Press and hold this switch to reset the setting for the selection. <p>⇒ Refer to the vehicle Owner's Manual for details.</p>
(4)		<p>Following distance setting switch</p> <ul style="list-style-type: none"> • Press this switch to select the set following distance in 4 stages (only when Adaptive Cruise Control is on). ⇒ Page 57 • When the main cruise control is on, switching between Adaptive Cruise Control and Conventional Cruise Control is possible by pressing the  (Following distance setting) switch*. <p>*: To switch to Conventional Cruise Control, press and hold the switch for approximately 2 seconds or longer.</p>
(5)	CANCEL	<p>CANCEL (pull the cruise control switch toward you)</p> <p>Pull this switch to cancel cruise control*.</p> <p>⇒ Pages 58 and 94</p> <p>*: Adaptive Cruise Control and Conventional Cruise Control</p>

<p>(6)</p>	<p>+ RES</p>	<p>+ RES (push the cruise control switch up)</p> <ul style="list-style-type: none"> • Push this switch up to set cruise control*. • After cruise control* is canceled, push this switch up to resume cruise control* at the vehicle speed that was previously set. • Push this switch up to increase the set vehicle speed (when cruise control* is currently set). <p>⇒ Pages 46, 53 and 63 (for Adaptive Cruise Control) ⇒ Pages 86, 92 and 98 (for Conventional Cruise Control) *: Adaptive Cruise Control and Conventional Cruise Control</p>
<p>(7)</p>	<p>− SET</p>	<p>− SET (push the cruise control switch down)</p> <ul style="list-style-type: none"> • Push this switch down to set cruise control*. • Push this switch down to reduce the set vehicle speed (when cruise control* is currently set). <p>⇒ Pages 46 and 55 (for Adaptive Cruise Control) ⇒ Pages 86 and 93 (for Conventional Cruise Control) *: Adaptive Cruise Control and Conventional Cruise Control</p>
<p>(8)</p>	<p>ON-OFF</p>	<p>ON-OFF switch</p> <p>Press this switch to turn cruise control* on/off.</p> <p>When  (Adaptive Cruise Control indicator) or  (Conventional Cruise Control indicator) is shown on the combination meter display, the main cruise control is on.</p> <p>⇒ Pages 46 and 86 *: Adaptive Cruise Control and Conventional Cruise Control</p>

Center information display

■ Changing settings

The EyeSight settings can be changed by operating the center information display.

⇒ Page 105

The Reverse Automatic Braking (RAB) system can also be turned on/off by operating the center information display. (AT models)

⇒ Refer to the vehicle Owner's Manual for details.

■ Warning screens

The following warning screens will be displayed on the center information display.

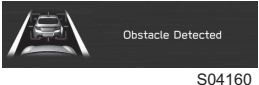
Displayed screen	Item
	Pre-Collision Braking System warning (first braking and secondary braking)
	"Obstacle Detected" warning

Pre-Collision Braking System

When there is the risk of a rear-end collision with an obstacle or pedestrian in front, the EyeSight system helps to prevent or minimize a collision by warning the driver. If the driver still does not take evasive action to avoid a collision, the brakes can be automatically applied just before the collision in order to reduce impact damage, or if possible, prevent the collision. If the driver takes evasive action to avoid a collision, Pre-Collision Braking Assist will operate in order to help the driver to prevent or minimize the collision.

- AT models: This function can be activated when the select lever is in the “D”, “M” or “N” position.
- MT models: This function can be activated when the gear position indicator shows a position other than “R”.



WARNING

- Never use Pre-Collision Braking System and Pre-Collision Braking Assist to stop your car or avoid a collision under ordinary conditions. These functions cannot prevent collisions under all conditions. If the driver relies only on Pre-Collision Braking System for Brake operation, collisions may occur.
- When a warning is activated, pay attention to the front of the vehicle and its surroundings, and operate the brake pedal and/or take other actions if necessary.
- The EyeSight Pre-Collision Braking System is primarily designed to prevent rear-end collisions with other vehicles when possible or to minimize damage and injuries in the event of a collision. In addition to other vehicles, things such as motorbikes, bicycles and pedestrians can also be treated as obstacles. However, there may be cases when detection is not possible depending on a variety of conditions*². For example, when a vehicle is viewed from the side, oncoming vehicle, vehicles approaching in reverse, small animals or children, or walls or doors are not likely to be detected.
- Pre-Collision Braking System will operate at the point when it determines that a collision cannot be avoided and is designed to apply strong braking force just before a collision. The result of this varies depending on a variety of conditions*². Because of this, performance of this function will not always be the same.
- When Pre-Collision Braking System is activated, it will continue to operate even if the accelerator pedal is partially depressed. However, it will be canceled if the accelerator pedal is suddenly or fully depressed.
- If the driver depresses the brake pedal or turns the steering wheel, the system may determine that this constitutes evasive action by the driver, and the automatic braking control may not activate in order to allow the driver full control.

- When the difference in speed with the obstacle in front is the following figure^{*1} or more, it may not be possible to avoid a collision. Even if the speed difference is the following figure^{*1} or less, in cases such as when another vehicle cuts in front of you, or in other cases depending on visibility, the condition of road surface and other factors^{*2}, the function may be unable to stop the vehicle or may not activate. Pre-Collision Braking Assist also may not activate depending on the conditions^{*2} listed below.

*1: For vehicles: approximately 50 km/h

For pedestrians: approximately 35 km/h

*2: Conditions in which Pre-Collision Braking System cannot detect obstacles:

- Distance to obstacle in front of you, speed difference, proximity conditions, lateral displacement (the amount of offset)
- Vehicle conditions (amount of load, number of occupants, etc.)
- Road conditions (grade, slipperiness, shape, bumps, etc.)
- Visibility ahead is poor (rain, snow, fog or smoke, etc.)
- The detected object is something other than a vehicle, motorcycle, bicycle or pedestrian.
 - A domestic animal or other animal (a dog or deer, etc.)
 - A guardrail, telephone pole, tree, fence or wall, etc.
- Even if the obstacle is a motorcycle, bicycle or pedestrian, depending on the brightness of the surroundings as well as the relative movement, and aspect or angle of the object, there may be cases when the system cannot detect it.
- The system determines that operation by the driver (based on accelerator pedal operation, braking, steering wheel angle, etc.) is intended as evasive action.
- Vehicle maintenance status (brake systems, tire wear, tire pressure, whether a temporary spare tire is being used, etc.)
- A trailer or another vehicle, etc. is being towed.
- The brakes are cold due to the outside temperature being low or just after starting the engine.
- The brakes are overheated on downhill grades (braking performance is reduced).
- In rain or after washing the vehicle (the brakes are wet and braking performance is reduced.)

Continued on next page ⇒

⇒ Continued from previous page

- Recognition conditions of the stereo camera

In particular, the function may be unable to stop the vehicle or may not activate in the following cases.

- Bad weather (for example heavy rain, a blizzard or thick fog)
- Visibility is poor due to sand, smoke or water vapor blowing in the wind, or the front vision is obscured due to water splashes, snow, dirt or dust stir up generated by the vehicle in front or oncoming traffic.
- At night or in a tunnel without the headlights on
- At night or in a tunnel when there is a vehicle in front that does not have its taillights on
- Approaching a motorcycle, bicycle or pedestrian at night
- Ambient light is poor in the evening or early morning.
- A vehicle, motorcycle, bicycle or pedestrian is outside the area illuminated by the headlights.
- Strong light is coming from the front (for example, sunlight at dawn, sunset or headlight beams, etc.).
- The stereo camera's field of view is obstructed by fogging, snow, dirt, frost, dust, scratches, or smears on the windshield, or by light reflecting off the dirt, etc.
- Fluid has not been fully wiped off the windshield during or after washer use.
- The target cannot be correctly recognized because the stereo camera's view is obstructed by water droplets from rain or the window washer, or by the wiper blades.
- The stereo camera's field of view is obstructed.
- The rear aspect of the vehicle in front is low, small or irregular (the system may recognize another part of the vehicle as its rear and will determine operation from that).

- There is an empty truck or trailer with no rear and/or side panels on the cargo bed.
- Vehicles that have cargo protruding from their back ends
- Non-standard shaped vehicles (vehicle transporters or vehicles with a sidecar fitted, etc.)
- The height of the vehicle is low, etc.

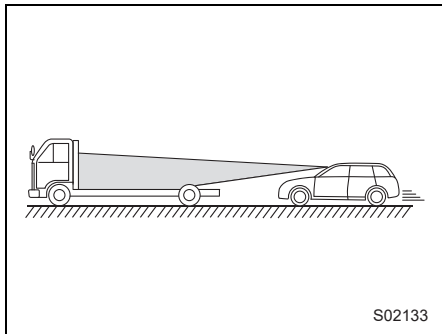

- There is a wall, etc. in front of a stopped vehicle.
- There is another object near the vehicle.
- A vehicle, etc. has its side facing you.
- With vehicles that are backing up or with oncoming vehicles, etc.
- The size and height of an obstacle is smaller than the limitations of the stereo camera's recognition capability.
 - With small animals or children, etc.
 - With pedestrians who are sitting or lying down
- The detected object is a fence or wall, etc. with a uniform pattern (a striped pattern or brick pattern, etc.).
- There is a wall or door made of glass or a mirror in front.
- The vehicle in front suddenly swerves, accelerates, or decelerates.
- A vehicle, motorcycle, bicycle or pedestrian suddenly cuts in from the side or suddenly runs in front of you.
- Your vehicle is immediately behind an obstacle after changing lanes.
- There is a vehicle, motorcycle, bicycle or pedestrian in a location close to your vehicle's bumper.
- The speed difference between your vehicle and an obstacle is approximately 5 km/h or less (As braking is performed once the obstacle is in close proximity to your vehicle, depending on the shape and size of the obstacle, there may be some cases when the obstacle is outside the range of the camera's field of view.).
- On sharp curves, steep uphill grades or steep downhill grades
- On a bumpy or unpaved road
- There are changes in brightness, such as at a tunnel entrance or exit.
- Do not test Pre-Collision Braking System on its own. It may operate improperly and cause an accident.

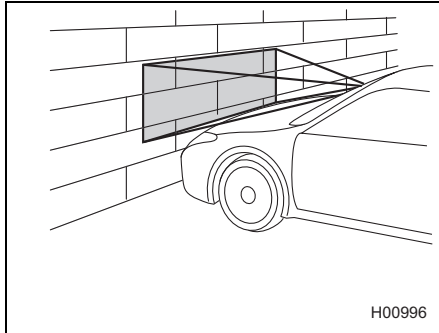

Continued on next page ⇒

⇒ Continued from previous page

- The system may not operate correctly under the conditions listed below. When these conditions occur, turn off Pre-Collision Braking System.

⇒ Page 37

- The tire pressure is not correct.*¹
- The temporary spare tire is installed.*¹
- Tires that are unevenly worn or tires with uneven wear patterns are installed.*¹
- Tires that are the wrong size are installed.*¹
- A flat tire has been fixed temporarily with a tire repair kit.
- The suspension has been modified (including a genuine SUBARU suspension that has been modified).
- An object that obstructs the stereo camera's view is installed on the vehicle.
- Tire chains are installed.
- The headlights are dirty or they have snow and ice or dirt on them. (Objects are not correctly illuminated and are difficult to detect.)
- The optical axes are not aligned correctly. (Objects are not correctly illuminated and are difficult to detect.)
- The lights including headlights and fog lights have been modified.
- Vehicle operation has become unstable due to an accident or malfunction.
- The brake system warning light (red) is illuminated.*²
- A heavy cargo is inside the vehicle.
- The maximum number of occupants is exceeded.
- The combination meter is not operating properly; such as when the lights do not illuminate, the beeps do not sound, the display is different from when it is normal (for example, the gear position indicator differs from the actual position of the shift lever), etc.*³

*1: The wheels and tires have functions that are critically important. Be sure to use the correct ones. For details, refer to the vehicle Owner's Manual.

*2: If the brake system warning light (red) does not turn off, immediately pull the vehicle over in a safe place and contact a SUBARU dealer to have the system inspected. For details, refer to the vehicle Owner's Manual.

*3: For details about the combination meter, refer to the vehicle Owner's Manual.

CAUTION

- In the following situations, turn off Pre-Collision Braking System. Otherwise Pre-Collision Braking System may activate unexpectedly.

⇒ Page 37

- The vehicle is being towed.
- The vehicle is being loaded onto a carrier.
- A chassis dynamometer, free-rollers or similar equipment is being used.
- A mechanic lifts up the vehicle, starts the engine and spins the wheels freely.
- Passing hanging banners, flags or branches
- Thick/tall vegetation is touching the vehicle.
- Driving on a race track
- In a drive-through car wash

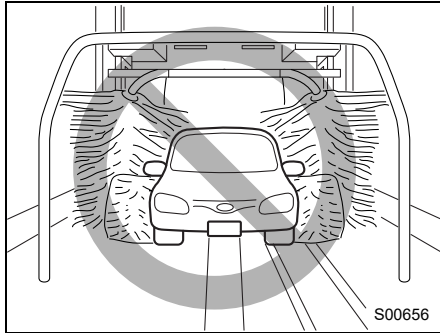

- Pre-Collision Braking System may activate in the following situations. Therefore concentrate on safe driving.

- Passing through an automatic gate (opening and shutting)
- Driving close to the vehicle in front
- Driving in a location where the grade of the road changes rapidly

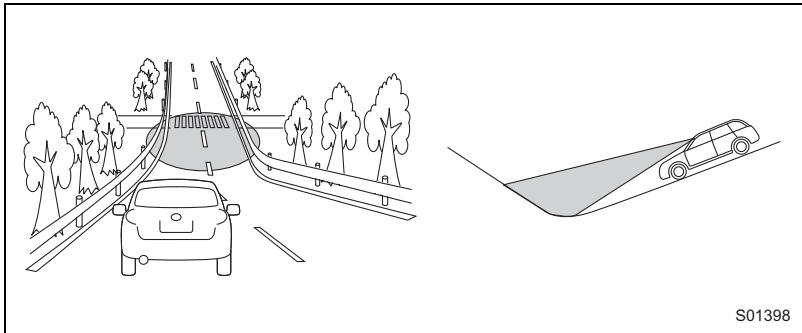

Continued on next page ⇒

⇒ Continued from previous page

- Visibility is poor due to sand, smoke or water vapor blowing in the wind, or the front vision is obscured due to water splashes, snow, dirt or dust stir up generated by the vehicle in front or oncoming traffic.
- Passing through clouds of steam or smoke, etc.
- In adverse weather, such as heavy snow or snowstorms
- The exhaust gas emitted by the vehicle in front is clearly visible in cold weather, etc.

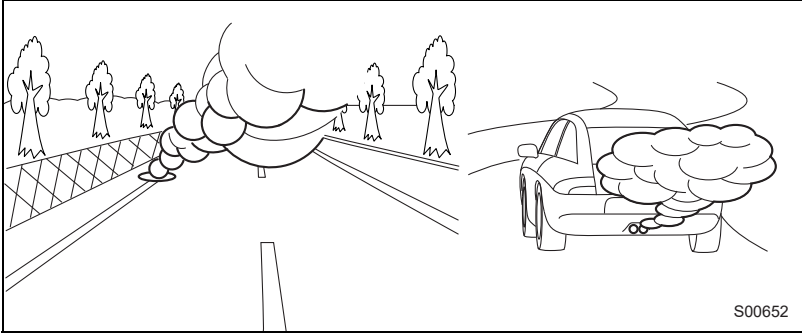

- There is an obstacle on a curve or intersection.
- A vehicle or an object is being narrowly passed.
- Stopping very close to a wall or a vehicle in front

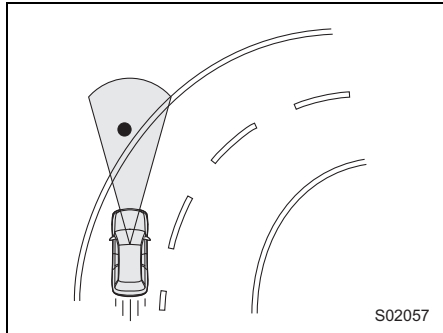

- Passing through water spray from road sprinklers or snow clearing sprinklers on the road

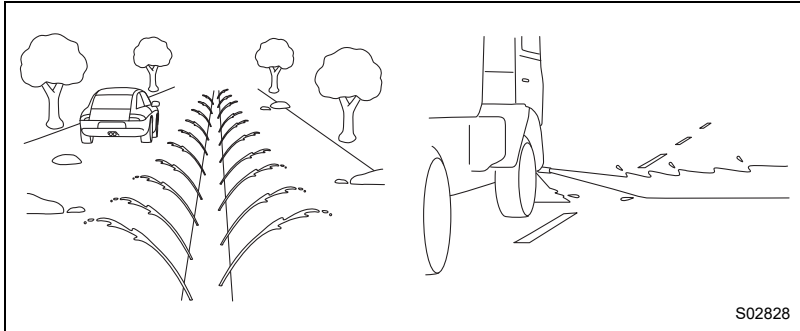

- If there are installed accessories, etc. that are protruding beyond the edge of the front bumper, the vehicle's length will increase and the system may not be able to prevent a collision.
- If the driver operates the brake pedal during automatic braking, the pedal may feel stiff; however, this is normal. By depressing the brake pedal further you can apply more braking force.

**NOTE**

Some unusual noises may be audible during automatic braking. This is caused by the braking control and is normal.

Detection of pedestrians

The EyeSight system can also detect pedestrians. The EyeSight system detects pedestrians from their size, shape and movement. The system detects a pedestrian when the contour of the head and shoulders are clear.

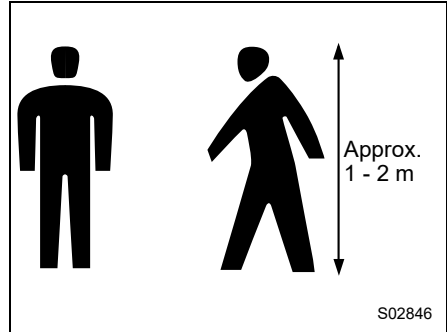

WARNING

Pre-Collision Braking System also identifies pedestrians as obstacles. However, depending on the conditions, there may be cases when the system cannot detect a pedestrian. In the following conditions, the possibility that the system may not be able to detect a pedestrian as an object is particularly high.

- Pedestrians are walking in a group.
- A pedestrian is next to a wall or other obstacle.
- A pedestrian is using an umbrella.
- A pedestrian is wearing clothes that are a similar color to the surrounding environment.
- A pedestrian is carrying bulky luggage.
- A pedestrian is bent over, crouching down or lying down.
- A pedestrian is in a dark location.
- A pedestrian suddenly crosses in front of you from the side or suddenly runs in front of you.

Pre-Collision Braking System operation

When there is an obstacle in front of you during driving, the system activates in the following sequence in order to warn the driver and to activate braking control and the brake lights.

Following Distance Warning:

When the system determines that there is a risk of collision, an alert sounds repeated short beeps and an interruption screen is displayed on the combination meter display to warn the driver.

When the driver depresses the brake pedal to decelerate and achieves a suitable following distance, the warning is canceled.

First Braking and Warning:

When the system determines that there is a high risk of collision with an obstacle in front, an alert sounds repeated short beeps and an interruption screen is displayed on the combination meter display to warn the driver. Braking control may be activated and in some situations, engine output may also be controlled. If the system determines that the amount of evasive action (braking, steering, etc.) taken by the driver has reduced the risk of collision, braking activation is canceled.

Secondary Braking and Warning:

If the system then determines that the risk of collision is extremely high, the alert changes to a continuous beeping sound and stronger braking control is activated. Despite any evasive action taken by the driver, if the system subsequently determines that a collision is unavoidable, the system continues to control braking and engine output.

When the vehicle is completely stopped by the automatic braking system, a short tone “3 intermittent beeps, 1 short beep and 1 long beep” will sound and braking will be gradually released.

Depress the brake pedal after the vehicle has stopped to ensure that the vehicle stays stopped.



NOTE

- Neither first braking nor secondary braking will operate in the following cases.
 - Vehicle Stability Control (VSC) is active.
 - AT models: The vehicle speed is approximately 1 km/h or less (approximately 4 km/h or less when the select lever is in the “N” position), or approximately 160 km/h or more.
 - MT models: The vehicle speed is approximately 1 km/h or less (approximately 8 km/h or less when the shift lever is in the neutral position and the shift lever is operated or the clutch pedal is depressed), or approximately 160 km/h or more.
- If the system detects the brake lights of the vehicle in front, your vehicle will start decelerating earlier than if it does not.
- There are some cases where the first braking is applied for a longer period of time. One of the reasons for this is due to a large speed difference with an obstacle in front. In those cases, stronger or weaker braking control may be activated.

After the Pre-Collision Braking System operation, an interruption screen appears and stays on the combination meter display for a certain period of time.

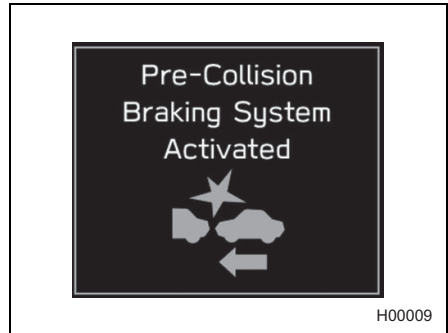

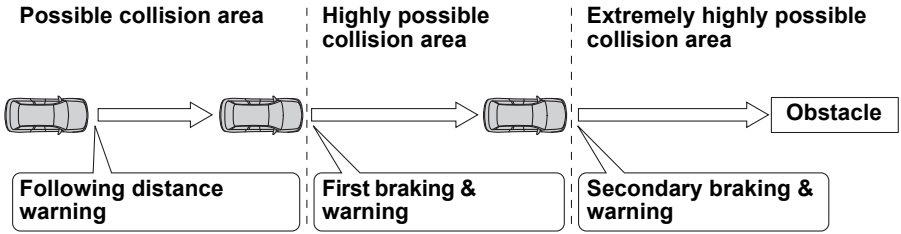

H01238

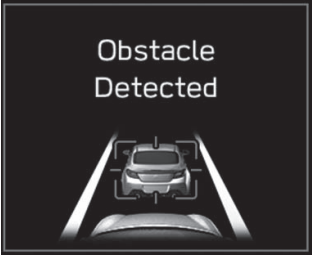
Operating system	Strength of Automatic Braking	Indication on the combination meter display	Alert type
Following distance warning	Weak	 <p>H00010</p>	Repeated short beeps
First braking	Moderate		Repeated short beeps
Secondary braking	Strong		Single continuous beep

Pre-Collision Braking Assist operation

When Pre-Collision Braking System is activated (when the system determines that there is a high risk of collision with an obstacle in front), if the driver depresses the brake pedal, the system determines that this is emergency braking and activates braking assist automatically.



CAUTION

If the driver depresses the brake pedal while following distance warning is activated, the Pre-Collision Braking Assist will not work. The vehicle decelerates with the normal braking force operated by the driver.



NOTE

- Pre-Collision Braking Assist function does not operate when the vehicle speed is approximately 10 km/h or less, or approximately 160 km/h or more.
- For information about the brake assist function, refer to the vehicle Owner's Manual.

Turning on/off Pre-Collision Braking System

Center information display

Operate the center information display to turn on/off Pre-Collision Braking System (including Pre-Collision Braking Assist).

This function is turned on by selecting “Setting ON” on the “Pre-Collision Braking” screen of the EyeSight settings.

This function is turned off by selecting “Setting OFF” on the “Pre-Collision Braking” screen of the EyeSight settings.

⇒ Page 105

Combination meter display

Also you can turn on/off Pre-Collision Braking System (including Pre-Collision Braking Assist) using the meter operation switch.

This function is turned on by selecting “ON” on the “PCB (Pre-Collision Braking System)” screen of the Driver Assist settings.

This function is turned off by selecting “OFF” on the “PCB (Pre-Collision Braking System)” screen of the Driver Assist settings.

⇒ Page 107

If Pre-Collision Braking System is turned off,  (Pre-Collision Braking System OFF indicator light) illuminates on the combination meter.

If Pre-Collision Braking System is turned on,  (Pre-Collision Braking System OFF indicator light) turns off on the combination meter.



NOTE

- The on/off setting for Pre-Collision Braking System operates in cooperation with Pre-Collision Throttle Management. (AT models)
- Even when Pre-Collision Braking System is turned off, if the engine is restarted, Pre-Collision Braking System will turn on. The system default setting when the vehicle is restarted is on.



■ Pre-Collision Braking System OFF indicator light

This indicator light illuminates when the ignition switch is turned to the ON position, and then turns off several seconds after the engine starts.

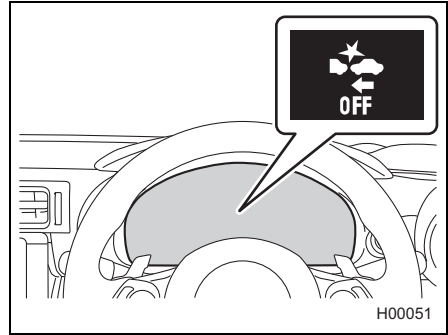
- AT models: It illuminates when Pre-Collision Braking System and Pre-Collision Throttle Management are turned off.
- MT models: It illuminates when Pre-Collision Braking System is turned off.





It also illuminates under the following conditions.

- TRC system and Vehicle Stability Control (VSC) are set to off.
⇒ Refer to the vehicle Owner's Manual for details.
- The EyeSight system has a malfunction.  (EyeSight warning indicator: Yellow)
⇒ Page 101
- The EyeSight system has stopped temporarily.  (EyeSight temporary stop indicator: White)
⇒ Page 103



NOTE

- AT models: When  (Pre-Collision Braking System OFF indicator light) illuminates, Pre-Collision Braking System (including the Pre-Collision Braking Assist function) and Pre-Collision Throttle Management do not operate.
- MT models: When  (Pre-Collision Braking System OFF indicator light) illuminates, Pre-Collision Braking System (including the Pre-Collision Braking Assist function) does not operate.

Adaptive Cruise Control

Adaptive Cruise Control is a driving support system intended to allow more comfortable driving on expressways, freeways and motorways. The stereo camera detects vehicles in front that are driving in the same traffic lane, and your vehicle follows the vehicle in front up to the set vehicle speed. While following, your vehicle will automatically maintain a following distance that corresponds to the speed of the vehicle in front. Please remember that you should not exceed posted speed limits.

- AT models: The vehicle is capable of being controlled at a speed between 0 km/h and approximately 145 km/h.
- MT models: The vehicle is capable of being controlled at a speed between approximately 30 km/h and 145 km/h.



WARNING

- This system does not provide the driver with an automatic driving function that handles all traffic conditions.
- Do not rely excessively on Adaptive Cruise Control. This system is not intended to assist in driving when the driver is not paying full attention to what is ahead of him/her due to distractions or a lack of concentration while driving, or under conditions of poor visibility. It is not intended to prevent rear-end collisions.
Strive for safe driving at all times. Always maintain a safe following distance behind the vehicle in front of you, pay attention to your surroundings and the driving conditions, and operate the brake pedal and take other actions as necessary.
- When using Adaptive Cruise Control, always set the speed according to the speed limit, traffic flow, road conditions, and other conditions.
- Before using the system, perform a daily inspection and verify that there are no malfunctions of the tires or brakes.
- The system may not operate correctly under the conditions listed below. When these conditions occur, do not use Adaptive Cruise Control.
 - The tire pressure is not correct.*1
 - The temporary spare tire is installed.*1
 - Tires that are unevenly worn or tires with uneven wear patterns are installed.*1
 - Tires that are the wrong size are installed.*1
 - A flat tire has been fixed temporarily with a tire repair kit.
 - The suspension has been modified (including a genuine SUBARU suspension that has been modified).
 - An object that obstructs the stereo camera's view is installed on the vehicle.
 - Tire chains are installed.
 - The headlights are dirty or they have snow and ice or dirt on them. (Objects are not correctly illuminated and are difficult to detect.)

Continued on next page ⇒

⇒ Continued from previous page

- The optical axes are not aligned correctly. (Objects are not correctly illuminated and are difficult to detect.)
- The lights including headlights and fog lights have been modified.
- Vehicle operation has become unstable due to an accident or malfunction.
- The brake system warning light (red) is illuminated.*²
- A heavy cargo is inside the vehicle.
- The maximum number of occupants is exceeded.
- The combination meter is not operating properly; such as when the lights do not illuminate, the beeps do not sound, the display is different from when it is normal, etc.*³

*1: The wheels and tires have functions that are critically important. Be sure to use the correct ones. For details, refer to the vehicle Owner's Manual.

*2: If the brake system warning light (red) does not turn off, immediately pull the vehicle over in a safe place and contact a SUBARU dealer to have the system inspected. For details, refer to the vehicle Owner's Manual.

*3: For details about the combination meter, refer to the vehicle Owner's Manual.

- Adaptive Cruise Control is designed for use on expressways, freeways, toll roads, motorways and similar limited access roads. It is not intended to be used in city traffic. In the following conditions, do not use Adaptive Cruise Control. Doing so may result in an accident.
 - Ordinary roads (roads other than those mentioned above)
Depending on the driving environment (complexity of roads and other factors), the system may not be able to perform as the traffic conditions require, and that may result in an accident.
 - Sharp curves or winding roads
 - Frozen roads, snow-covered roads or other slippery road surfaces
The tires may spin, causing loss of control of the vehicle.
 - Traffic conditions when frequent acceleration and deceleration make it difficult to maintain the following distance
It may not be possible for the system to perform as the traffic conditions require.
 - Steep downhill grades
The set vehicle speed may be exceeded.
 - On a steep continuous downhill grade
The brakes may overheat.

- Roads and overpasses with repeated steep uphill and downhill grades
Detection of the vehicle in front may be lost, or the road surface may be detected instead of the vehicle in front, making correct control impossible.
- Entering a sharp curve/turn into an interchange or junction, or a service area, parking area, toll booth or other facilities
Detection of the vehicle in front may not be possible.
- There are changes in brightness, such as at a tunnel entrance or exit.
- Visibility is poor due to sand, smoke or water vapor blowing in the wind, or the front vision is obscured due to water splashes, snow, dirt, water spray from road sprinklers or snow clearing sprinklers on the road, or dust stir up generated by the vehicle in front or oncoming traffic.
Detection of the vehicle in front may be lost, or water or other substances may be incorrectly detected instead, making correct control impossible.

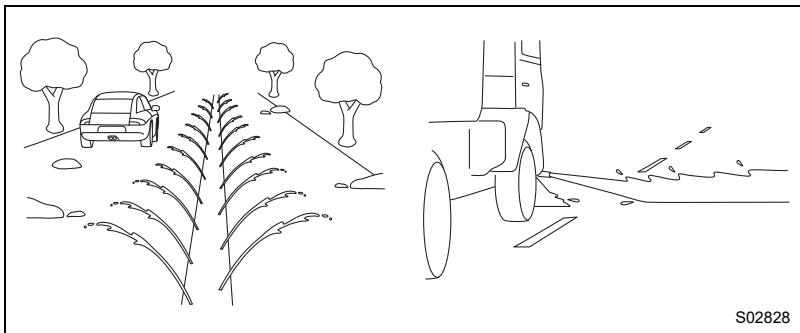
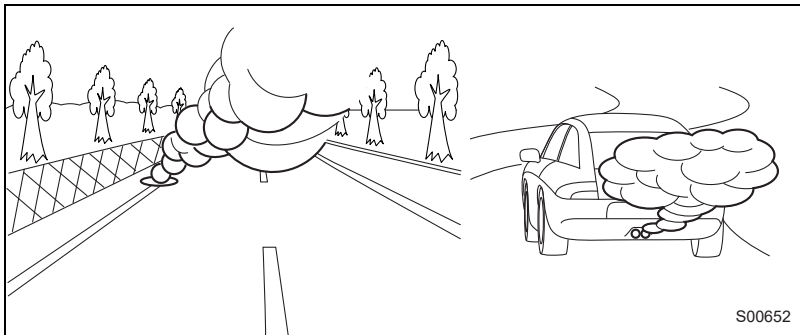

- In adverse weather, such as heavy snow or snowstorms
- The stereo camera's field of view is obstructed by fogging, snow, dirt, frost, dust, scratches, or smears on the windshield, or by light reflecting off the dirt, etc.

Continued on next page ⇒

⇒ Continued from previous page

- Water droplets from rain or the window washer, or dirt has not been fully wiped off the windshield.
It may not be possible to detect the vehicle in front, making correct control impossible.
- The stereo camera's field of view is obstructed.
- The stereo camera may have difficulty detecting the following objects or conditions. Operate the brake pedal and take other actions as necessary.
 - Vehicles at significantly different speeds (vehicles driving slowly, stopped or oncoming vehicles, etc.)
 - Vehicles cutting into your lane
 - Motorcycles, bicycles, pedestrians and animals, etc.
 - Light is poor in the evening or early morning.
 - At night or in a tunnel without the headlights on
 - At night or in a tunnel when there is a vehicle in front that does not have its taillights on
 - Strong light is coming from the front (sunlight or headlight high beams, etc.).
 - The rear aspect of the vehicle in front is low, small or irregular (the system may recognize another part of the vehicle as its rear and will determine operation from that).
 - There is an empty truck or trailer with no rear and/or side panels on the cargo bed.
 - Vehicles that have cargo protruding from their back ends
 - Non-standard shaped vehicles (vehicle transporters or vehicles with a sidecar fitted, etc.)
 - The height of the vehicle is low, etc.
 - Objects that are located close to the bumper of your vehicle
- When you do not use Adaptive Cruise Control, be sure to turn it off. If the function is left on, the function may operate unexpectedly, causing an accident.

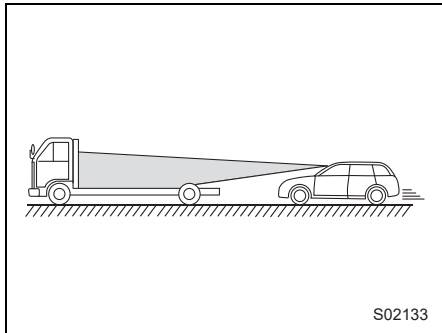

⇒ Page 64

- Before using Adaptive Cruise Control, be sure to fully verify the safety of the vehicle occupants and the area around the vehicle. Never operate the cruise control from outside the vehicle.

Detection of the vehicle in front by the stereo camera*

- Under the following road conditions or conditions of your vehicle, detection of the vehicle in front may not be possible. Vehicles in neighboring traffic lanes or roadside objects may also be incorrectly detected. Under conditions such as these, do not use Adaptive Cruise Control. If cruise control is currently in use, operate the brake pedal and take other actions as necessary.

- Following begins from a short following distance, such as when the vehicle in front is a vehicle that cut into your lane.

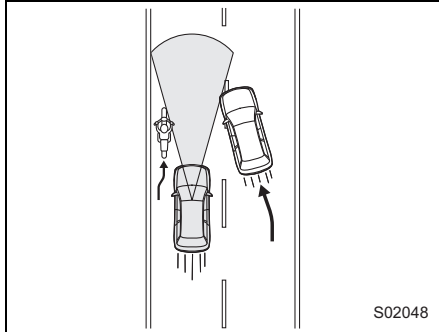

- On curved roads, at the start and end of a curve and on roads with continuous curves (These conditions make it difficult for the system to detect vehicles because they are outside the detectable area.)
- On an on-ramp or off-ramp to a freeway, highway, or other restricted access road (Adaptive Cruise Control is not designed for use in this kind of driving environment.)

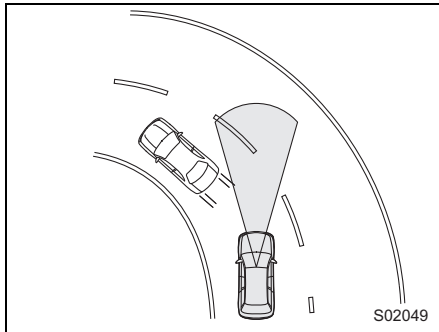

- In an urban or suburban environment (Adaptive Cruise Control is not appropriate for use in these driving areas. Use Adaptive Cruise Control only on limited-access highways.)

Continued on next page ⇒

⇒ Continued from previous page

- The vehicle in front is not directly ahead of your vehicle and is shifted to one side.

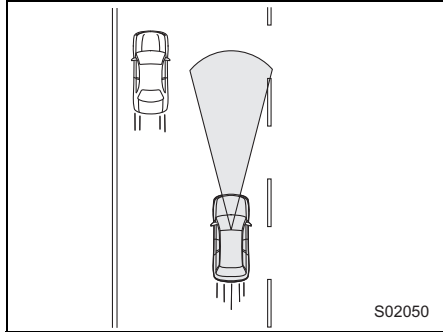

- There is an obstacle on the side of the road.
- The relative speed difference compared to the vehicle in front is large.
- A vehicle cuts into your lane in front of you.
- The distance between vehicles is extremely short.
- Your vehicle is drifting within the lane.
- On a bumpy or unpaved road surface

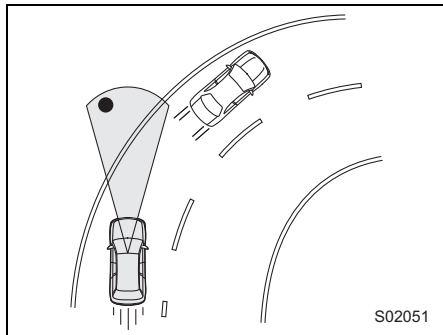

- On a road with extremely narrow lanes, such as when traffic restrictions are in effect or in areas where construction work is taking place
- Normal driving has become unstable due to an accident or malfunction.
- Extremely heavy cargo is loaded in the rear seat or trunk of your vehicle.
- There are limits to the situation judgment capabilities of the Adaptive Cruise Control system. Deceleration may not take place in time in the following situations. Depress the brake pedal to decelerate the vehicle if necessary.
 - The speed difference with the vehicle in front is too large or the vehicle in front decelerates unexpectedly.
 - The decelerating vehicle in front unexpectedly slows down or suddenly brakes.
- If the alert/notification sounds frequently, do not use Adaptive Cruise Control.

- Even when the following distance is short, the “Obstacle Detected” warning may not activate in the following situations.
 - The difference in speed with the vehicle in front is small. The two vehicles are traveling at almost the same speed.
 - The vehicle in front is traveling faster than your vehicle. The following distance is gradually increasing.
 - Another vehicle cuts into your lane very close to your vehicle.
 - The vehicle in front decelerates suddenly.
 - There are repeated uphill and downhill grades.
- ⇒ Page 65

*: The recognition status of the lead vehicle using the stereo camera can be confirmed by the illumination status of the lead vehicle indicator.
 ⇒ Page 46



Braking may not be sufficient depending on the following conditions. Depress the brake pedal and decelerate as necessary.

- Vehicle conditions (amount of load, number of occupants, etc.)
- Road conditions (grade, slipperiness, shape, bumps, etc.)
- Vehicle maintenance condition (brake systems, tire wear, air pressure, temporary spare tire is being used, etc.)
- The brakes are cold. (For example, just after the engine is started or the outside temperature is low.)
- For a short period of time when driving after the engine is started until the engine has warmed-up
- The brakes are overheated on downhill grades (braking performance may be reduced).
- In rain or after washing the vehicle (the brakes may become wet and braking performance may be reduced.)

How to use Adaptive Cruise Control

■ Setting Adaptive Cruise Control

1. Setting Adaptive Cruise Control to standby status

Press the ON-OFF switch. At this time,  (Adaptive Cruise Control indicator) (white) and the following distance setting indicator are displayed on the combination meter display.

The set vehicle speed display will read “- - km/h”.

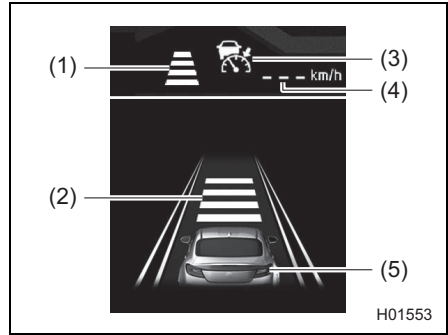
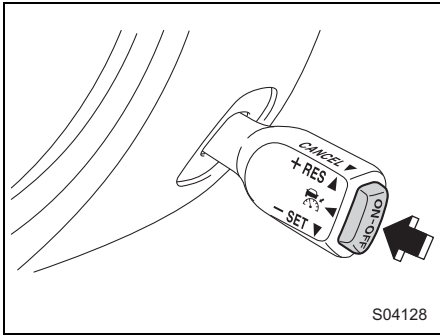

- (1) Following distance setting indicator (icon)
- (2) Following distance setting indicator
- (3) Adaptive Cruise Control indicator (white)
- (4) Set vehicle speed
- (5) Your vehicle indicator



NOTE

When the meter information screen is set to display content other than the EyeSight screen, the following distance setting indicator is shown as an icon.

To set the ready status:

When all of the following conditions are met, **READY** (READY indicator) is displayed on the combination meter display, and Adaptive Cruise Control can be activated.

AT models:

- Both the driver's door and the front passenger's door are closed.
- The driver's seatbelt is fastened.
- The select lever is in the "D" or "M" position.
- The brake pedal is not depressed.
- EyeSight operation is not temporarily stopped.  (EyeSight temporary stop indicator: White) is off.
⇒ Page 103
- The road is not a steep slope.
- The steering wheel has not been turned significantly in either direction.
- The vehicle speed is between 0 km/h and approximately 145 km/h.
- Parking brake is released.
- The driving mode is set to normal mode or sport mode.
⇒ Refer to the vehicle Owner's Manual for details.
- Pre-Collision Braking System is not turned off during TRACK mode.
⇒ Refer to the vehicle Owner's Manual for details.
- TRC system and Vehicle Stability Control (VSC) are not set to off.
⇒ Refer to the vehicle Owner's Manual for details.

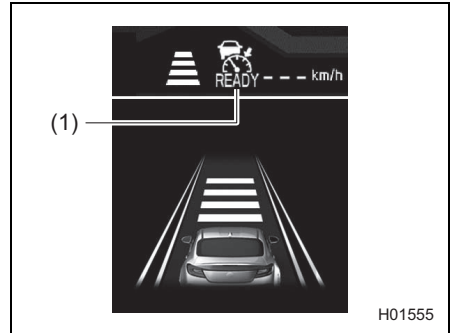

(1) READY indicator

MT models:

- Both the driver's door and the front passenger's door are closed.
- The driver's seatbelt is fastened.
- The shift lever is in a position from "2" to "6".
- The brake pedal is not depressed.
- The clutch pedal is not depressed.
- EyeSight operation is not temporarily stopped.  (EyeSight temporary stop indicator: White) is off.
 - ⇒ Page 103
- The road is not a steep slope.
- The steering wheel has not been turned significantly in either direction.
- The vehicle speed is between approximately 30 km/h and 145 km/h.
- Parking brake is released.
- Pre-Collision Braking System is not turned off during TRACK mode.
 - ⇒ Refer to the vehicle Owner's Manual for details.
- TRC system and Vehicle Stability Control (VSC) are not set to off.
 - ⇒ Refer to the vehicle Owner's Manual for details.

2. Setting Adaptive Cruise Control

Push the cruise control switch to the "+ RES" side or the "- SET" side.

The vehicle speed at the time the switch is pushed becomes the set vehicle speed, and Adaptive Cruise Control activates.

If no vehicle in front has been detected, the vehicle drives at the constant set vehicle speed.

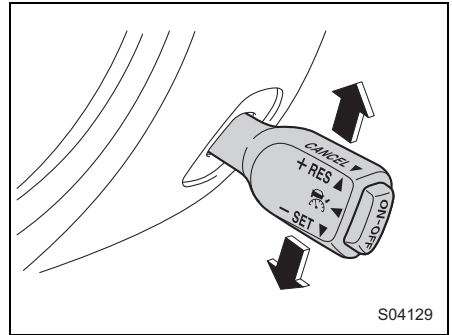

S04129

When Adaptive Cruise Control is activated, **READY** (READY indicator) turns off, the set vehicle speed is displayed, and  (Adaptive Cruise Control indicator) changes from white to green.

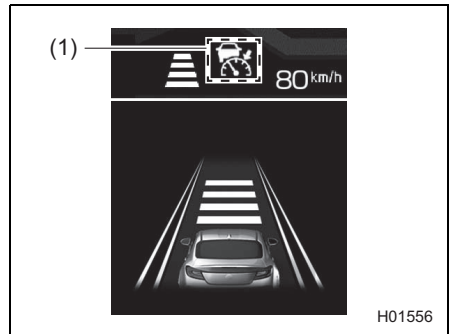

H01556

(1) Green





WARNING

When using Adaptive Cruise Control, always set the speed according to the speed limit, traffic flow, road conditions, and other conditions.



NOTE

- The set vehicle speed can be set between 30 km/h and 145 km/h.
- If the vehicle speed is approximately 30 km/h or less when the vehicle speed is set, the set vehicle speed is set to 30 km/h. (AT models)
- When driving on a curve, the vehicle may not accelerate, or may decelerate, even if the set vehicle speed is higher than the current vehicle speed.
- If  (Adaptive Cruise Control indicator) does not illuminate even when the ON-OFF switch is pressed, Adaptive Cruise Control will not operate.
- If  (Adaptive Cruise Control indicator) does not illuminate even when the ON-OFF switch is pressed and this occurs frequently, there may be a malfunction in the system. Contact a SUBARU dealer and have the system inspected.

When a vehicle in front is detected, the lead vehicle indicator will illuminate.

The vehicle follows the lead vehicle in front and maintains the selected following distance. At this time, the cruise speed is adjusted to and will not exceed the set vehicle speed. If the vehicle in front is no longer detected, the lead vehicle indicator turns off.

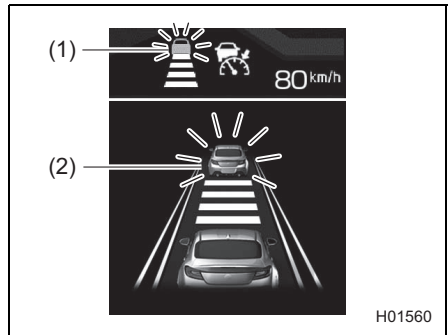

H01560

- (1) Lead vehicle indicator (icon)
- (2) Lead vehicle indicator



NOTE

- When the meter information screen is set to display content other than the EyeSight screen, the lead vehicle indicator is shown as an icon.
⇒ Refer to the vehicle Owner's Manual for details.
- The notification sound (lead vehicle acquisition sound) that occurs when a vehicle in front is detected or no longer detected while Adaptive Cruise Control is activated can be turned on by customization.
⇒ Page 105

Operation of Adaptive Cruise Control

- When no vehicle in front is detected
The vehicle drives constantly and correspondingly to the set vehicle speed between 30 km/h and 145 km/h.

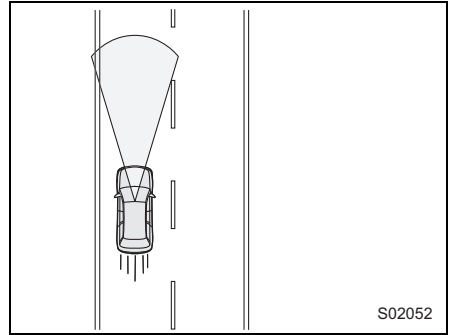

- When a vehicle in front is detected
The vehicle follows the lead vehicle in front, and will maintain the chosen following distance (there are four settings), up to the set vehicle speed between 30 km/h and 145 km/h.

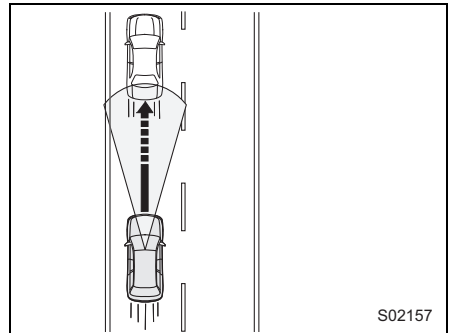

- If your vehicle no longer detects the vehicle in front
The vehicle accelerates back to the set vehicle speed and will drive at that constant speed.
If a vehicle in front is detected while accelerating to the set vehicle speed, vehicle following will be started again.

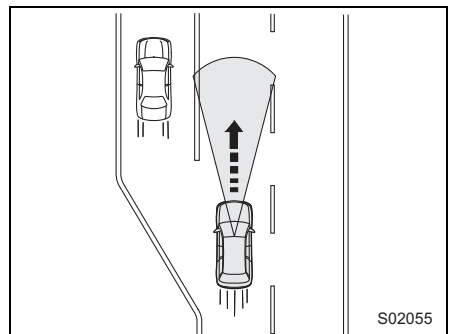



CAUTION

If the driver operates the brake pedal during automatic braking, the pedal may feel stiff; however, this is not a malfunction. By depressing the brake pedal further you can apply more braking force. When the brake pedal is released it will return to its original condition.



NOTE

- When the brakes are applied by Adaptive Cruise Control, the vehicle's brake lights will illuminate.
- Even if there is no lead vehicle present, on a downhill grade, the Adaptive Cruise Control's automatic brake may operate in order to maintain the set vehicle speed.
- Some noises may be audible during automatic braking. This is caused by the braking control and does not indicate a malfunction.
- To temporarily accelerate quickly, use the accelerator pedal. After accelerating, the vehicle will gradually return to the set vehicle speed shown in the set vehicle speed display.
- If the vehicle in front is no longer detected while your vehicle is still controlled by the automatic braking operation, the brake will be automatically released gradually. Depress the accelerator pedal if necessary.
- The lead-vehicle following function has the following characteristics:
 - If the lead vehicle's brake lights are detected, deceleration will start earlier than without detection.
 - If the vehicle moves to the fast lane while traveling more than approximately 60 km/h, the system starts acceleration to the set vehicle speed more quickly because it is linked with the turn signal.
 - If the setting of Driving Lane Customize is different from the actual driving direction, the vehicle may start to accelerate faster than usual when the driver signals a lane change to move from the passing lane to the driving lane.

⇒ Page 105

■ Increasing the set vehicle speed

● Using the cruise control switch

- Push to the “+ RES” side briefly.
Every time the switch is pushed, the set vehicle speed will increase to the next 5 km/h increment.
- Push to the “+ RES” side continuously.
While the switch is being pushed, the set vehicle speed will increase in increments of 1 km/h.

When operating the switch, the set vehicle speed changes on the combination meter display.

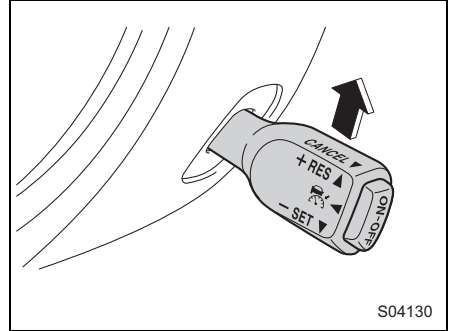

● Using the accelerator pedal

1. Depress the accelerator pedal to increase vehicle speed.
2. When the desired speed is reached, push the cruise control switch to the “- SET” side.

The speed at the time of pushing the switch will be set as the new set vehicle speed, and it appears on the combination meter display.

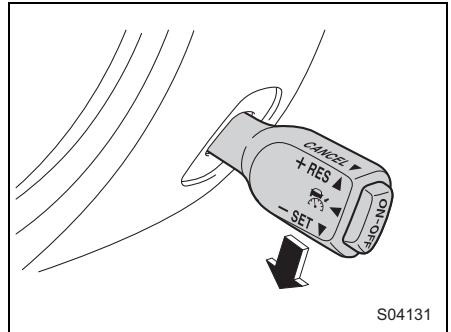

 **CAUTION**

- When the vehicle is following the lead vehicle, the actual vehicle speed is controlled according to the lead vehicle. Therefore, if the cruise control switch is pushed to the “+ RES” side and set to a speed higher than the speed of the lead vehicle, the vehicle will not accelerate; it will maintain a safe following distance as the first priority. However, because doing so changed the set vehicle speed, when the lead vehicle is no longer detected (for example, if you change to a freeway lane with no vehicles in front), the vehicle will accelerate to that new set vehicle speed. Change the set vehicle speed while briefly checking the value shown in the set vehicle speed display on the combination meter display.
- When the accelerator pedal is depressed with Adaptive Cruise Control on, automatic braking control and warnings by Adaptive Cruise Control will not occur. However, if there is a high risk of collision with an obstacle in front of the vehicle at this time, the warning and braking control of Pre-Collision Braking System may activate.

■ Decreasing the set vehicle speed

● Using the cruise control switch

- Push to the “- SET” side briefly.
Every time the switch is pushed, the set vehicle speed will decrease to the next 5 km/h decrement.
- Push to the “- SET” side continuously.
While the switch is being pushed, the set vehicle speed will decrease in decrements of 1 km/h.

When operating the switch, the set vehicle speed changes on the combination meter display.

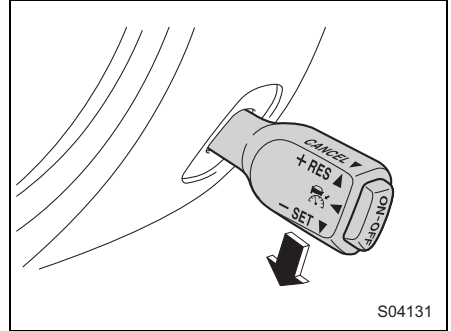



● Using the brake pedal

1. Depress the brake pedal to decrease the vehicle speed.
Adaptive Cruise Control will be canceled and  (Adaptive Cruise Control indicator) changes from green to white.
2. When the desired speed is reached, push the cruise control switch to the “- SET” side.
The speed at the time of pushing the switch will be set as the new set vehicle speed, and it appears on the combination meter display.

■ Accelerating temporarily

Depress the accelerator pedal to accelerate temporarily.

When the accelerator pedal is released, the vehicle returns to the set vehicle speed.

When the driver accelerates the vehicle by depressing the accelerator pedal while Adaptive Cruise Control is operating,  (Adaptive Cruise Control indicator) turns white. When the acceleration is completed,  (Adaptive Cruise Control indicator) returns to green.

■ Decelerating temporarily

Depress the brake pedal to decelerate temporarily. When the brake pedal is depressed, Adaptive Cruise Control will be canceled.

 (Adaptive Cruise Control indicator) changes from green to white while the set vehicle speed remains displayed on the combination meter display.

Release the brake pedal and push the cruise control switch to the “+ RES” side to restore the set vehicle speed.

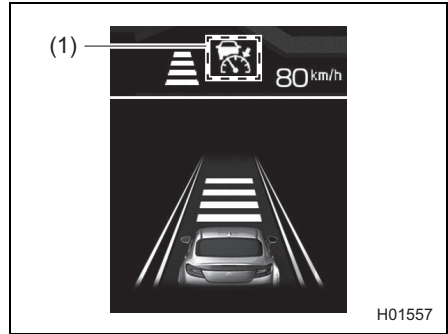

(1) White

CAUTION

When following another vehicle while using Adaptive Cruise Control, your vehicle will accelerate or slow down based on the speed of the lead vehicle.

However, the driver always remains responsible for safe driving and should not rely too much on the system.

If you need to accelerate (for example, to make a lane change) or slow down (for example, because the lead vehicle suddenly slows down or another vehicle cuts into your path), then operate either the accelerator or the brake pedal as appropriate based on surrounding conditions.

■ Changing the following distance from the vehicle in front

The following distance from the vehicle in front setting can be changed in 4 stages.

Each time the  (Following distance setting) switch is pressed, the distance from the vehicle in front changes.

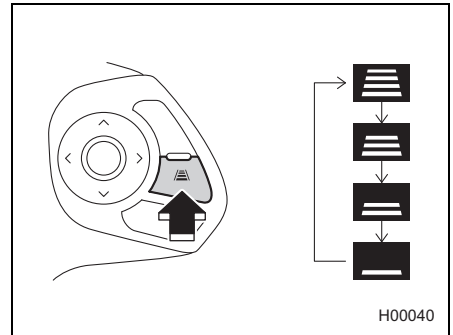





H00040



NOTE

- The following distance changes corresponding with the vehicle speed. The faster the vehicle travels, the greater the following distance.

Approximate guide to following distances

Following distance indicator	When your vehicle speed is 40 km/h	When your vehicle speed is 100 km/h
	Approx. 30 m	Approx. 60 m
	Approx. 25 m	Approx. 50 m
	Approx. 20 m	Approx. 40 m
	Approx. 15 m	Approx. 30 m

- The following distance previously set is restored when you turn back on Adaptive Cruise Control by pressing the ON-OFF switch.

■ Canceling Adaptive Cruise Control

● Canceling by driver operation

Any of the following operations will cancel Adaptive Cruise Control.

 (Adaptive Cruise Control indicator) changes from green to white while the set vehicle speed remains displayed on the combination meter display.

- Depress the brake pedal.

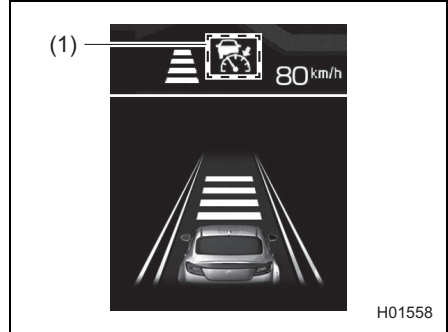

(1) White

- Pull the cruise control switch to the CANCEL side.

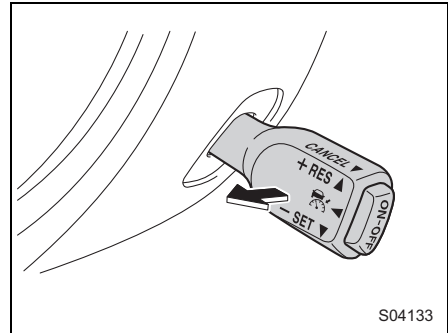

● Automatic cancellation by the system



WARNING







- Do not use Adaptive Cruise Control on slippery roads. Doing so may result in an accident.
- After Adaptive Cruise Control has started, it maintains control continuously according to the behavior of the vehicle in front. If your vehicle speed falls below approximately 25 km/h because the vehicle in front slows down, Adaptive Cruise Control is automatically canceled. Depress the brake pedal and decelerate as necessary. (MT models)



CAUTION



- When the Adaptive Cruise Control system brings your vehicle to a complete stop, 3 intermittent beeps, 1 short beep and 1 long beep will sound, and the Adaptive Cruise Control system will be automatically canceled. Because the automatic braking function will be gradually released, make sure to stop the vehicle completely by depressing the brake pedal after the vehicle has stopped. (AT models)
- AT models: When the select lever is shifted to the “N” position, Adaptive Cruise Control will be automatically canceled. Do not shift the select lever to the “N” position except in an emergency. Otherwise, the engine brake may not operate, which could cause an accident.
- MT models: If the shift lever is left in the neutral position for approximately 5 seconds or longer, Adaptive Cruise Control will be automatically canceled. Do not leave the shift lever in the neutral position. Otherwise, engine braking will not be effective, which could cause an accident.

**NOTE**

- If EyeSight is malfunctioning,  (EyeSight warning indicator: Yellow) is displayed on the combination meter display, and  (Pre-Collision Braking System OFF indicator light) and  (Lane Departure Warning OFF indicator light) illuminate. If this occurs, stop the vehicle in a safe location and then turn off the engine and restart it. If the indicators remain illuminated after restarting the engine, Adaptive Cruise Control cannot be used. This will not interfere with ordinary driving. However, contact a SUBARU dealer and have the system inspected.
⇒ Page 101
- If the EyeSight operation has temporarily stopped,  (Pre-Collision Braking System OFF indicator light) and  (Lane Departure Warning OFF indicator light) illuminate, and  (EyeSight temporary stop indicator: White) is displayed on the combination meter display.
⇒ Page 103
- When the operation of Adaptive Cruise Control has been automatically canceled, perform the Adaptive Cruise Control setting operation again after the condition that caused the cancellation has been corrected. If Adaptive Cruise Control cannot be activated even after the condition has been corrected, EyeSight may be malfunctioning. This will not interfere with ordinary driving. However, contact a SUBARU dealer and have the system inspected.

Under the following conditions, a notification sounds 1 short beep and 1 long beep, and Adaptive Cruise Control is automatically canceled.  (Adaptive Cruise Control indicator) changes from green to white. Also, an interruption screen is displayed on the combination meter display.



AT models:

- The grade of the road is very steep.
- TRC system or Vehicle Stability Control (VSC) is activated.
- The vehicle speed has exceeded approximately 160 km/h while cruise control is activated.
- The steering wheel is turned significantly in either direction.
- The select lever is moved to a position other than “D” or “M”.
- Either the driver’s door or the front passenger’s door is opened.
- The driver’s seatbelt is unfastened.
- The EyeSight system has a malfunction.  (EyeSight warning indicator: Yellow)
⇒ Page 101
- The EyeSight system has stopped temporarily.  (EyeSight temporary stop indicator: White)
⇒ Page 103
- The Pre-Collision secondary braking is activated.
- Parking brake is applied.
- The engine revolutions approached the red zone.
- The driving mode is set to snow mode.
⇒ Refer to the vehicle Owner’s Manual for details.
- Pre-Collision Braking System is turned off during TRACK mode.
⇒ Refer to the vehicle Owner’s Manual for details.
- TRC system and Vehicle Stability Control (VSC) are off.
⇒ Refer to the vehicle Owner’s Manual for details.
- The driving wheels spin on a slippery road.



After the conditions have been resolved, perform the Adaptive Cruise Control set operation again to reactivate Adaptive Cruise Control.

MT models:

- The grade of the road is very steep.
- TRC system or Vehicle Stability Control (VSC) is activated.
- Vehicle speed drops to approximately 25 km/h or less while cruise control is activated.
- The vehicle speed has exceeded approximately 160 km/h while cruise control is activated.
- The steering wheel is turned significantly in either direction.
- The shift lever is in the "1" or "R" position, or the shift lever has been in the neutral position for approximately 5 seconds or longer.
- The clutch pedal is depressed for approximately 5 seconds or longer.
- Either the driver's door or the front passenger's door is opened.
- The driver's seatbelt is unfastened.
- The EyeSight system has a malfunction.  (EyeSight warning indicator: Yellow)
⇒ Page 101
- The EyeSight system has stopped temporarily.  (EyeSight temporary stop indicator: White)
⇒ Page 103
- The Pre-Collision secondary braking is activated.
- Parking brake is applied.
- The engine revolutions approached the red zone.
- Pre-Collision Braking System is turned off during TRACK mode.
⇒ Refer to the vehicle Owner's Manual for details.
- TRC system and Vehicle Stability Control (VSC) are off.
⇒ Refer to the vehicle Owner's Manual for details.
- The driving wheels spin on a slippery road.

After the conditions have been resolved, perform the Adaptive Cruise Control set operation again to reactivate Adaptive Cruise Control.

■ Restoring the previously set vehicle speed

The previously set vehicle speed is stored in memory. To restore that vehicle speed, push the cruise control switch to the "+ RES" side.  (Adaptive Cruise Control indicator) changes from white to green.

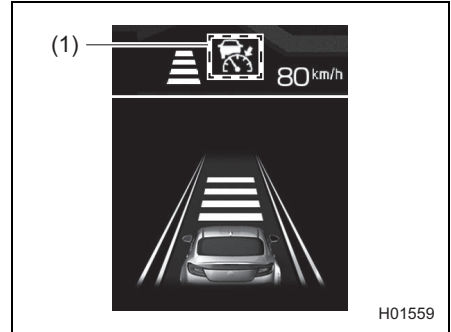
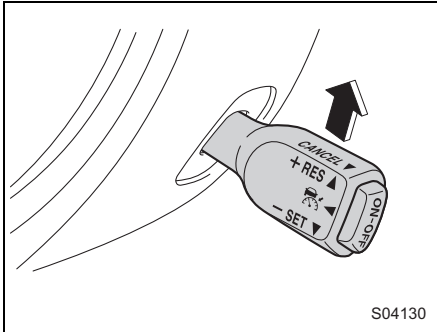

(1) Green



NOTE

- The vehicle speed stored in memory is erased in the following circumstances:
 - The cruise control is turned off by pressing the ON-OFF switch.
 - TRC system or Vehicle Stability Control (VSC) is activated.
 - The cruise control mode was switched from Adaptive Cruise Control to Conventional Cruise Control.
- If there is no vehicle speed stored in memory (previous vehicle speed), the current vehicle speed is set when the cruise control switch is pushed to the "+ RES" side.
 - ⇒ Page 46

■ Turning off Adaptive Cruise Control

Press the ON-OFF switch.

 (Adaptive Cruise Control indicator) and the following distance setting indicator turn off on the combination meter display, and Adaptive Cruise Control turns off.

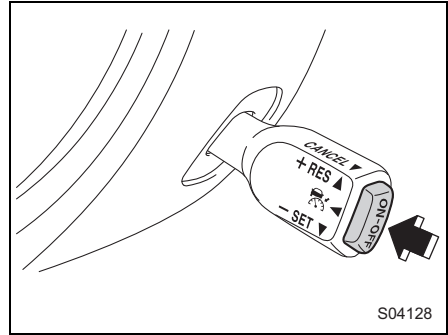

S04128

Other functions

■ “Obstacle Detected” warning

The “Obstacle Detected” warning is activated while Adaptive Cruise Control is following a lead vehicle. This function warns the driver when it determines that the current level of deceleration by automatic braking control is insufficient.

- When the system determines that the vehicle speed needs to be reduced manually by the driver, an alert sounds repeated short beeps and an interruption screen is displayed.
- When this function activates, depress the brake pedal to decelerate and maintain an optimal following distance.

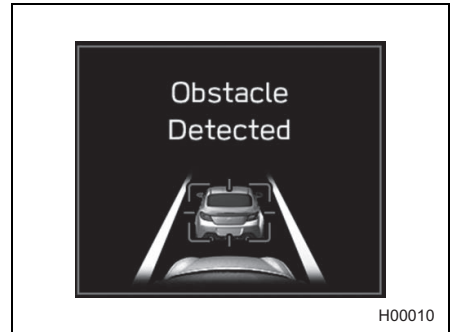

WARNING

- If the alert/notification sounds frequently, do not use Adaptive Cruise Control.
- The “Obstacle Detected” warning will not activate in the following situations.
 - The accelerator pedal is depressed.
 - The brake pedal is depressed.
- Even when the following distance is short, the “Obstacle Detected” warning may not activate in the following situations.
 - The difference in speed with the vehicle in front is small. The two vehicles are traveling at almost the same speed.
 - The vehicle in front is traveling faster than your vehicle. The following distance is gradually increasing.
 - Another vehicle cuts into your lane very close to your vehicle.
 - The vehicle in front decelerates suddenly.
 - There are repeated uphill and downhill grades.
- The “Obstacle Detected” warning may not activate in time in the case of a vehicle that is stopped at the end of a line at a toll gate, at a stop light or intersection or in traffic congestion, or a vehicle that is moving much slower than your vehicle. EyeSight requires a speed differential in order to recognize a potential obstacle and react to it.



NOTE

Vehicles in front in the same traffic lane are detected by the stereo camera within a distance of approximately 110 m in the forward direction. However the detection distance may be reduced depending on the traffic environment, driving conditions, and conditions of the vehicle in front.

Pre-Collision Throttle Management (AT models)

When an obstacle is detected in front of the vehicle, and the vehicle is stopped or traveling very slowly, if the system determines that the accelerator pedal has been depressed by more than the necessary amount (due to driver error), it greatly restricts engine output and ensures that vehicle forward movement is slower than normal in order to give the driver additional time to brake or react.

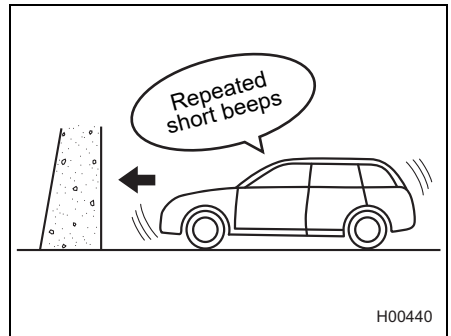

During system operation, an alert sounds repeated short beeps and an interruption screen is displayed.

This function only activates when the select lever is in the "D" or "M" position.

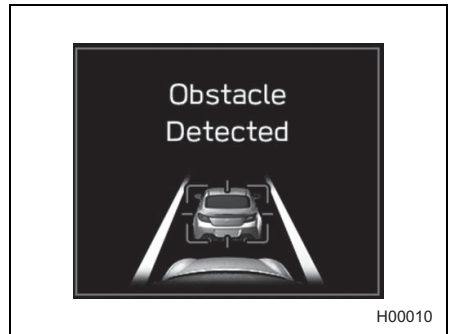

WARNING

Do not rely excessively on Pre-Collision Throttle Management. Pre-Collision Throttle Management is not designed to help you avoid collisions in all situations. Always check the select lever and pedal positions as well as the surrounding environment before starting and operating the vehicle. Relying only on Pre-Collision Throttle Management could result in an accident.

- Pre-Collision Throttle Management is not designed to maintain the vehicle in a stopped condition.
- Pre-Collision Throttle Management will not reduce acceleration under all conditions. It is also not designed to prevent collisions.
- Pre-Collision Throttle Management will operate when an obstacle is detected in front. However, this function will not reduce acceleration in cases where no obstacle is detected (for example when approaching a cliff, etc.).
- Do not intentionally depress the accelerator pedal excessively when there are obstacles nearby. If the driver relies only on Pre-Collision Throttle Management to control acceleration, collisions may occur.

Continued on next page ⇒

⇒ Continued from previous page

- If your vehicle is trapped on a railroad crossing and you are trying to escape by driving through the crossing gate, the stereo camera may recognize the crossing gate as an obstacle and the Pre-Collision Throttle Management system may activate. In this case, remain calm and either continue to depress the accelerator pedal or turn off the Pre-Collision Throttle Management system.

⇒ Page 72

- Pre-Collision Throttle Management may not activate depending on the following conditions:
 - The distance between your vehicle and the obstacle, speed difference, and horizontal offset
 - Recognition status of the stereo cameraIn particular, the function may not activate in the following cases:
 - Bad weather (for example heavy rain, a blizzard or thick fog)
 - Visibility is poor due to sand or smoke in the air.
 - Light is poor in the evening, early morning, or at night.
 - In a dark area (indoor parking area, etc.)
 - There is an obstacle outside the area illuminated by the headlights.
 - Strong light is coming from the front (for example sunlight at sunrise or sunset headlight beams, etc.).
 - The stereo camera's field of view is obstructed by fogging, snow, dirt, frost, dust, scratches, or smears on the windshield, or by light reflecting off the dirt, etc.
 - Fluid has not been fully wiped off the windshield during or after washer use.
 - Obstacles cannot be correctly recognized due to water droplets from rain or the washer, or the wiper blades obstructing the stereo camera's field of view.
 - The stereo camera's field of view is obstructed.
 - With low obstacles (low wall, crash barrier, low vehicle, etc.)
 - The size and height of an obstacle is smaller than the limitations of the stereo camera's recognition capability.
 - With small animals or children
 - With pedestrians who are sitting or lying down

- The rear portion nearest your vehicle is too small or too close (such as a trailer or oncoming vehicle). The system may not recognize the part of that vehicle which is closest to you.

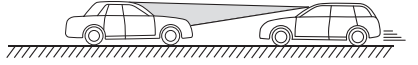
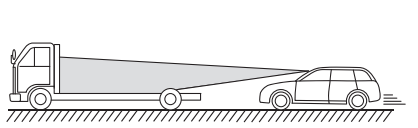

S02134

- There is a fence or wall, etc., with a uniform pattern (striped pattern, brick, etc.) or with no pattern in front.
- There is a wall or door made of glass or a mirror in front.
- An obstacle (another vehicle, motorcycle, bicycle, pedestrian, animal or child, etc.) cuts in from the side or jumps out suddenly.
- Your vehicle is immediately behind an obstacle after changing lanes.
- On sharp curves, steep uphill grades or steep downhill grades
- The system determines that steering operation by the driver is intended as evasive action.
- For your safety, do not test Pre-Collision Throttle Management on its own. It may operate improperly and cause an accident.

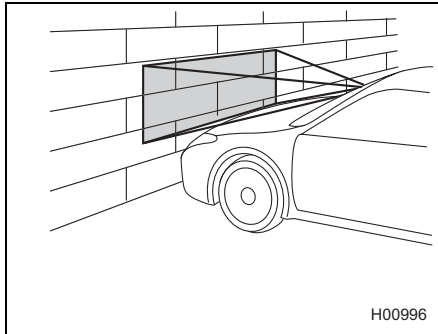

H00996

CAUTION

- In the following situations, turn off Pre-Collision Throttle Management. Otherwise Pre-Collision Throttle Management may activate unexpectedly.
⇒ Page 72
 - The vehicle is being towed.
 - The vehicle is being loaded onto a carrier.
 - A chassis dynamometer, free-rollers or similar equipment is being used.
 - A mechanic lifts up the vehicle, starts the engine and allows the wheels to spin freely.
 - Driving on a race track
 - Passing hanging banners, flags or branches
 - Thick/tall vegetation is touching the vehicle.
- Pre-Collision Throttle Management may activate in the following situations. Therefore concentrate on safe driving.
 - Your vehicle is close to the vehicle in front.
 - Passing through an automatic gate
 - Your vehicle is in a location where the grade of the road changes rapidly.

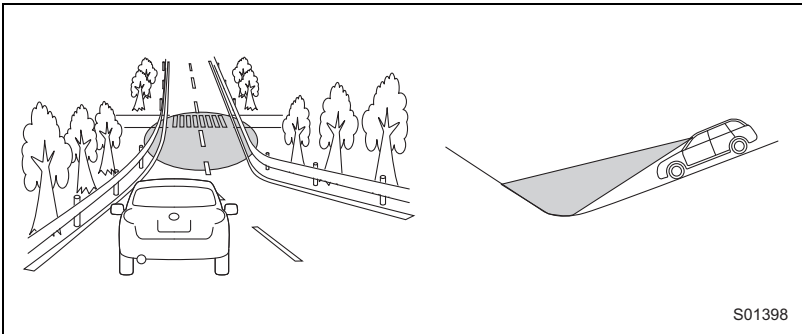

- Passing through clouds of steam or smoke

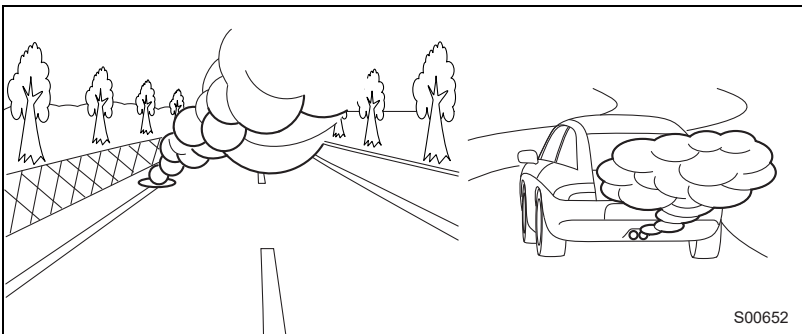

- Passing through water spray from road sprinklers or snow clearing sprinklers on the road

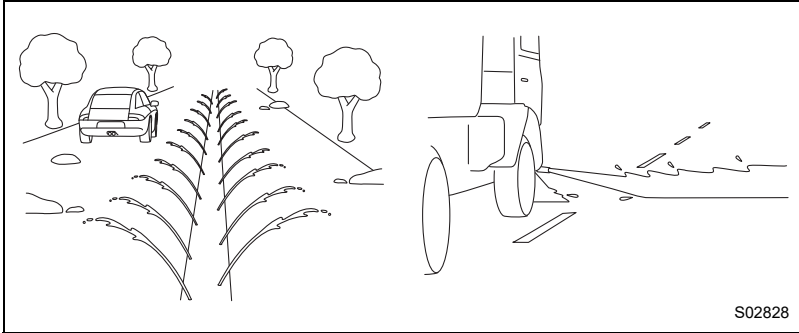

- In adverse weather, such as heavy snow or snowstorms
- There is an obstacle on a curve or intersection.
- A vehicle or an object is being narrowly passed.
- Stopping very close to a wall or a vehicle in front

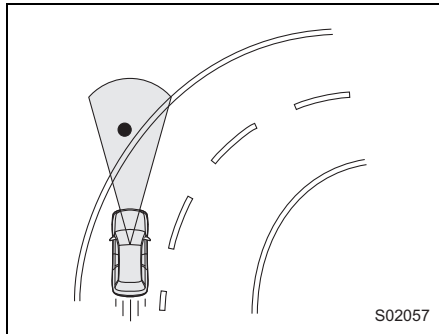

NOTE

- When the accelerator pedal is depressed for approximately 3 seconds, Pre-Collision Throttle Management will be released gradually.
 - When Pre-Collision Braking System is turned off, Pre-Collision Throttle Management is also turned off.
- ⇒ Page 37

Turning on/off Pre-Collision Throttle Management

Center information display

Operate the center information display to turn on/off Pre-Collision Throttle Management.

This function is turned on by selecting “Setting ON” on the “Pre-Collision Braking” screen of the EyeSight settings.

This function is turned off by selecting “Setting OFF” on the “Pre-Collision Braking” screen of the EyeSight settings.

⇒ Page 105

Combination meter display

Also you can turn on/off Pre-Collision Throttle Management using the meter operation switch.

This function is turned on by selecting “ON” on the “PCB (Pre-Collision Braking System)” screen of the Driver Assist settings.

This function is turned off by selecting “OFF” on the “PCB (Pre-Collision Braking System)” screen of the Driver Assist settings.

⇒ Page 107

If Pre-Collision Throttle Management is turned off,  (Pre-Collision Braking System OFF indicator light) illuminates on the combination meter.

If Pre-Collision Throttle Management is turned on,  (Pre-Collision Braking System OFF indicator light) turns off on the combination meter.





NOTE

- The on/off setting for Pre-Collision Throttle Management operates in cooperation with Pre-Collision Braking System.
- Even when Pre-Collision Throttle Management is turned off, if the engine is turned off and then restarted, Pre-Collision Throttle Management will be turned on. The system default setting when the vehicle is restarted is on.

■ Pre-Collision Braking System OFF indicator light

This indicator light illuminates when the ignition switch is turned to the ON position, and then turns off several seconds after the engine starts. It illuminates when Pre-Collision Braking System and Pre-Collision Throttle Management are turned off. It also illuminates under the following conditions.

- TRC system and Vehicle Stability Control (VSC) are set to off.
⇒ Refer to the vehicle Owner's Manual for details.
- The EyeSight system has a malfunction.  (EyeSight warning indicator: Yellow)
⇒ Page 101
- The EyeSight system has stopped temporarily.  (EyeSight temporary stop indicator: White)
⇒ Page 103

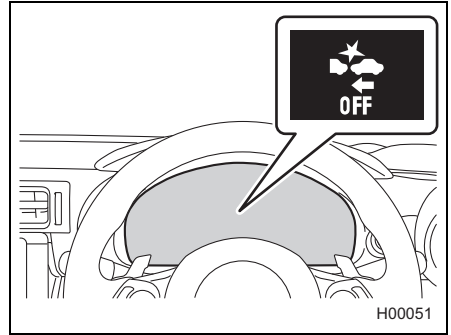

NOTE

When  (Pre-Collision Braking System OFF indicator light) illuminates, Pre-Collision Braking System (including the Pre-Collision Braking Assist function) and Pre-Collision Throttle Management do not operate.

Lane Departure Warning

When vehicle speed is approximately 50 km/h or more, this function warns the driver if the system detects that the vehicle is likely to depart the traffic lane.

When Lane Departure Warning activates, an alert sounds 3 short beeps and an interruption screen will be displayed.

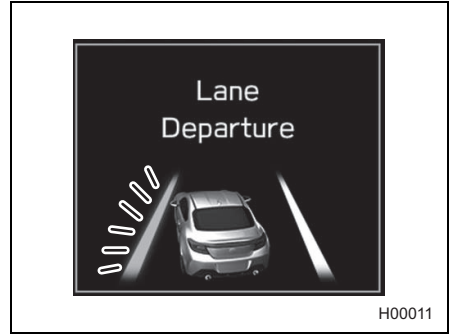
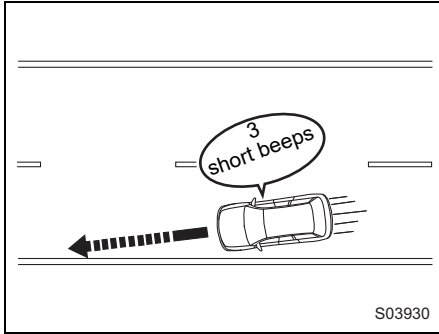

*: The illustration depicts a vehicle about to cross the left line.



WARNING

Lane Departure Warning will not operate in all conditions. It also will not automatically return the vehicle to the original lane. If the driver relies only on Lane Departure Warning to keep the vehicle in the lane, lane departure may occur, resulting in an accident.

Lane Departure Warning activates when it detects lane markings. However, it is not a function which can detect the edge of a road (shoulders or side ditches, etc.) and warn the driver.

 **CAUTION**

Under the following conditions, Lane Departure Warning may not operate:

- Vehicle speed is approximately 50 km/h or less.
- The steering wheel is turned significantly to either side.
- The vehicle is driving around a curve whose radius is 300 m or smaller.
- The brake pedal is depressed or immediately after it is depressed.
- The following distance behind a vehicle in front is short.
- The turn signal is operating.
- For approximately 4 seconds after the turn signal lever has returned to its original position
- The vehicle has not returned to the inside of the lane after Lane Departure Warning has activated.
- The lane is narrow.
- It is difficult for the camera to detect lane markings.
 - There are no lane markings or they are very worn.
 - The lane markings are yellow.
 - The lane markings are similar in color to the road surface.
 - The lane markings are narrow.

**NOTE**

- The following situations may cause incorrect lane detection and a faulty Lane Departure Warning to occur.
 - There are tire tracks on a wet road or snow-covered road.
 - There are boundaries between snow and asphalt, or marks from road repair, etc.
 - There are the shadows of guardrails.
 - Lane markings are drawn in double.
 - There are some lane markings left from roadwork or markings from the previous road.
- When  (Lane Departure Warning OFF indicator light) is illuminated, Lane Departure Warning will not operate.
⇒ Page 77

Turning on/off Lane Departure Warning

Center information display

Operate the center information display to turn on/off Lane Departure Warning.

This function is turned on by selecting “ON” on the “Lane Departure Warning” screen of the EyeSight settings.

This function is turned off by selecting “OFF” on the “Lane Departure Warning” screen of the EyeSight settings.

⇒ Page 105

Combination meter display

Also you can turn on/off Lane Departure Warning using the meter operation switch.

This function is turned on by selecting “ON” on the “LDW (Lane Departure Warning)” screen of the Driver Assist settings.

This function is turned off by selecting “OFF” on the “LDW (Lane Departure Warning)” screen of the Driver Assist settings.

⇒ Page 107

If Lane Departure Warning is turned off,  (Lane Departure Warning OFF indicator light) illuminates on the combination meter.

If Lane Departure Warning is turned on,  (Lane Departure Warning OFF indicator light) turns off on the combination meter.





NOTE

- The on/off setting for Lane Departure Warning operates in cooperation with Lane Sway Warning.
- The on/off status of Lane Departure Warning is restored when you restart the engine.

■ Lane Departure Warning OFF indicator light

This indicator light illuminates when the ignition switch is turned to the ON position, and then several seconds after the engine starts, it turns off or remains illuminated depending on the current status (on or off). It illuminates when Lane Departure Warning and Lane Sway Warning are turned off.

It also illuminates under the following conditions.

- Pre-Collision Braking System is turned off during TRACK mode.
⇒ Refer to the vehicle Owner's Manual for details.
- TRC system and Vehicle Stability Control (VSC) are off.
⇒ Refer to the vehicle Owner's Manual for details.
- The EyeSight system has a malfunction.  (EyeSight warning indicator: Yellow)
⇒ Page 101
- The EyeSight system has stopped temporarily.  (EyeSight temporary stop indicator: White)
⇒ Page 103

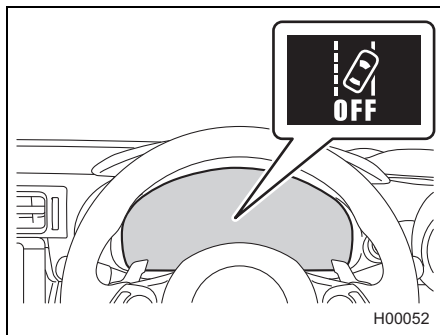

Lane Sway Warning

This function detects swaying or drifting within a lane, and warns the driver. When Lane Sway Warning activates, an alert sounds 3 short beeps and an interruption screen will be displayed.

This function activates when the vehicle speed exceeds approximately 60 km/h and deactivates when the vehicle speed falls below approximately 40 km/h. The function will reactivate when the vehicle speed is increased to exceed approximately 60 km/h.

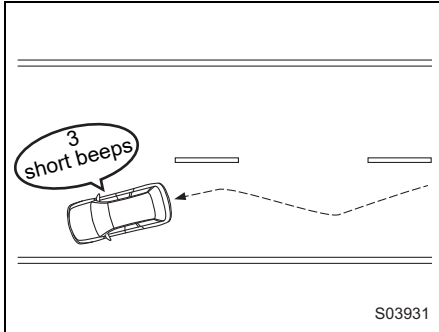

*: The lines on the right and left blink alternately.



WARNING

Lane Sway Warning will not operate in all conditions. It also will not automatically correct swaying. If the driver relies only on Lane Sway Warning to prevent the vehicle from swaying, an accident may occur.



CAUTION

Under the following conditions, Lane Sway Warning may not operate.

- On a winding road
- The vehicle speed changes greatly.
- Immediately after a lane change
- It is difficult for the stereo camera to detect lane markings.
 - There are no lane markings or they are the very worn.
 - The lane markings are yellow.
 - The lane markings are similar in color to the road surface.
 - The lane markings are narrow.

**NOTE**

- Swaying detection is based on several minutes of prior driving data. Swaying will not be detected immediately after the vehicle starts to sway. In addition, the warning may continue for some time even after swaying stops.
- Lane Sway Warning is just a function that warns the driver. When the driver is tired, not concentrating on the road or not paying adequate attention to driving, be sure to take rest breaks as often as needed.
- When  (Lane Departure Warning OFF indicator light) is illuminated, Lane Sway Warning will not operate.
⇒ Page 77

Turning on/off Lane Sway Warning

Center information display

Operate the center information display to turn on/off Lane Sway Warning.

This function is turned on by selecting “ON” on the “Lane Departure Warning” screen of the EyeSight settings.

This function is turned off by selecting “OFF” on the “Lane Departure Warning” screen of the EyeSight settings.

⇒ Page 105

Combination meter display

Also you can turn on/off Lane Sway Warning using the meter operation switch.

This function is turned on by selecting “ON” on the “LDW (Lane Departure Warning)” screen of the Driver Assist settings.

This function is turned off by selecting “OFF” on the “LDW (Lane Departure Warning)” screen of the Driver Assist settings.

⇒ Page 107

If Lane Sway Warning is turned off,  (Lane Departure Warning OFF indicator light) illuminates on the combination meter.

If Lane Sway Warning is turned on,  (Lane Departure Warning OFF indicator light) turns off on the combination meter.





NOTE

- The on/off setting for Lane Sway Warning operates in cooperation with Lane Departure Warning.
- The on/off status of Lane Sway Warning is restored when you restart the engine.

■ Lane Departure Warning OFF indicator light

This indicator light illuminates when the ignition switch is turned to the ON position, and then several seconds after the engine starts, it turns off or remains illuminated depending on the current status (on or off). It illuminates when Lane Departure Warning and Lane Sway Warning are turned off. It also illuminates under the following conditions.

- Pre-Collision Braking System is turned off during TRACK mode.
 - ⇒ Refer to the vehicle Owner's Manual for details.
- TRC system and Vehicle Stability Control (VSC) are off.
 - ⇒ Refer to the vehicle Owner's Manual for details.
- The EyeSight system has a malfunction.  (EyeSight warning indicator: Yellow)
 - ⇒ Page 101
- The EyeSight system has stopped temporarily.  (EyeSight temporary stop indicator: White)
 - ⇒ Page 103

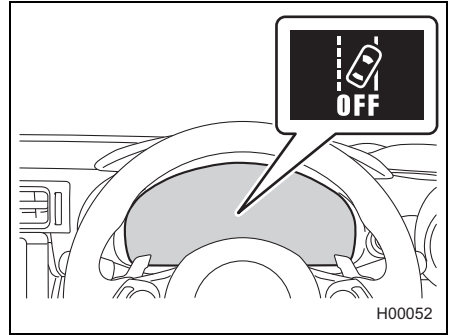

Lead Vehicle Start Alert

When the vehicle stopped in front starts to move, Lead Vehicle Start Alert notifies the driver with an interruption screen on the combination meter display and notification sound. When the vehicle in front remains stopped continuously (within a following distance of approximately 10 m and the driver's vehicle remains stopped for several seconds or longer), the system continues to detect the vehicle in front and this alert activates if the vehicle in front advances approximately 3 m or more while the driver's vehicle remains stationary.

When Lead Vehicle Start Alert activates, a notification sounds a two-tone beep and an interruption screen will be displayed.

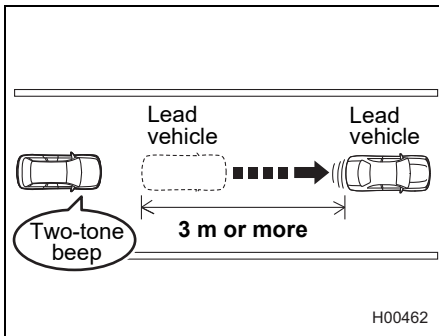

- AT models: This function only activates when the select lever is in the "D", "M" or "N" position.
- MT models: This function only activates when the brake pedal is depressed. It does not activate if the vehicle is stopped with the parking brake alone or the shift lever is in the "R" position.



WARNING

Even after alerts are given audibly and through an interruption screen, be sure to carefully check the area surrounding the vehicle before pulling away. Relying solely on Lead Vehicle Start Alert may result in an accident.

**NOTE**

- The Lead Vehicle Start Alert setting can be turned on or off.
⇒ Page 105
- Under the following conditions, Lead Vehicle Start Alert may activate even when the vehicle in front has not started to move, or may not activate even after the vehicle in front has started to move:
 - A motorcycle or similar object cuts in between your vehicle and the stopped vehicle in front.
 - Weather or road conditions may interfere with the detection of the vehicle in front.
 - The stereo camera loses detection of the vehicle in front.
- Lead Vehicle Start Alert activates even if the engine has stalled. However, it might not activate if, for example, there is an irregularity in the battery voltage when the engine is restarted. (MT models)
- Under the following conditions, Lead Vehicle Start Alert will not activate.
 - Pre-Collision Braking System is turned off during TRACK mode.
⇒ Refer to the vehicle Owner's Manual for details.
 - TRC system and Vehicle Stability Control (VSC) are off.
⇒ Refer to the vehicle Owner's Manual for details.
 - The EyeSight system has a malfunction.  (EyeSight warning indicator: Yellow)
⇒ Page 101
 - The EyeSight system has stopped temporarily.  (EyeSight temporary stop indicator: White)
⇒ Page 103

Conventional Cruise Control

Conventional Cruise Control is a driving support system intended to allow more comfortable driving on expressways, freeways and motorways. It can be used to travel at a constant speed by maintaining the vehicle speed set by the driver. Please remember that you should not exceed posted speed limits.



WARNING

- When Conventional Cruise Control is functioning, the system does not perform the following control to maintain a following distance, as when using Adaptive Cruise Control.



Strive for safe driving and depress the brake pedal to decelerate the vehicle as necessary in order to ensure a safe following distance from the vehicle in front.

- Under the following conditions, do not use Conventional Cruise Control. Doing so may result in an accident.
 - Roads with heavy traffic or roads with sharp curves
Maintaining an appropriate speed for such road conditions may be difficult.
 - Frozen roads, snow-covered roads or slippery road surfaces
The tires may spin, causing your vehicle to lose control.
 - Steep downhill grades
The set vehicle speed may be exceeded.
 - On a steep continuous downhill grade
The brakes may overheat.
- When using Conventional Cruise Control, always set the speed according to the speed limit, traffic flow, road conditions, and other conditions.



CAUTION

When using cruise control, be sure to check the combination meter display to confirm which cruise control mode is selected: Adaptive Cruise Control or Conventional Cruise Control.

- If Adaptive Cruise Control is selected,  (Adaptive Cruise Control indicator) illuminates.
- If Conventional Cruise Control is selected,  (Conventional Cruise Control indicator) illuminates.

**NOTE**

- When the main cruise control is off and the ON-OFF switch is pressed, Adaptive Cruise Control is activated.
- When the main cruise control is on, switching between Adaptive Cruise Control and Conventional Cruise Control is possible by pressing the  (Following distance setting) switch*.
 - *: To switch to Conventional Cruise Control, press and hold the switch for approximately 2 seconds or longer.
- Conventional Cruise Control can be used even when EyeSight is temporarily stopped.

How to use Conventional Cruise Control

■ Setting Conventional Cruise Control

1. Setting Adaptive Cruise Control to standby status

Press the ON-OFF switch. At this time,  (Adaptive Cruise Control indicator) (white) and the following distance setting indicator are displayed on the combination meter display.

The set vehicle speed display will read “- - - km/h”.

When the ON-OFF switch is pressed, the initial cruise control mode is always Adaptive Cruise Control.

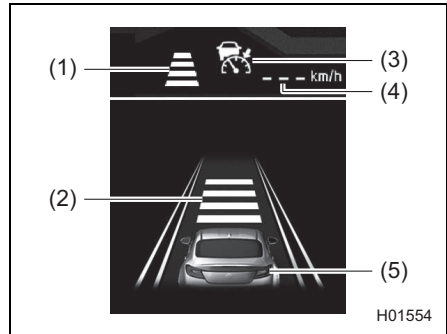
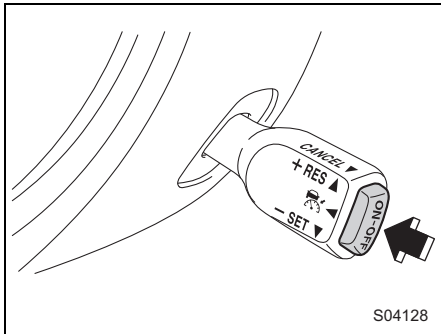

- (1) Following distance setting indicator (icon)
- (2) Following distance setting indicator
- (3) Adaptive Cruise Control indicator (white)
- (4) Set vehicle speed
- (5) Your vehicle indicator

2. Switch to Conventional Cruise Control.

Press and hold the  (Following distance setting) switch for approximately 2 seconds or longer to switch from Adaptive Cruise Control to Conventional Cruise Control. A notification sounds 1 short beep.

At this time, the following distance setting indicator on the combination meter display turns off and  (Conventional Cruise Control indicator) (white) is displayed.

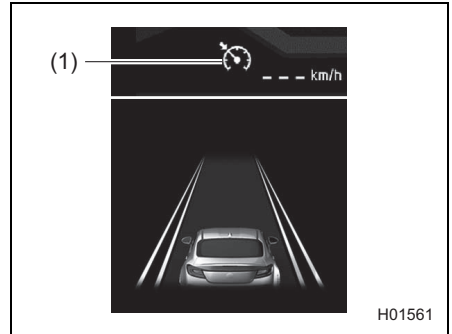
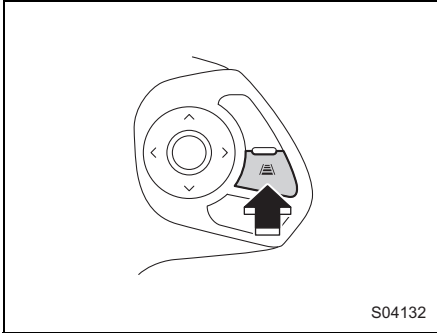

(1) Conventional Cruise Control indicator (white)

To set the ready status:

When all of the following conditions are met, **READY** (READY indicator) is displayed on the combination meter display, and Conventional Cruise Control can be activated.

AT models:

- Both the driver's door and the front passenger's door are closed.
- The driver's seatbelt is fastened.
- The select lever is in the "D" or "M" position.
- The brake pedal is not depressed.
- The road is not a steep slope.
- The steering wheel has not been turned significantly in either direction.
- The vehicle speed is between approximately 30 km/h and 145 km/h.
- Parking brake is released.
- The driving mode is set to normal mode or sport mode.
⇒ Refer to the vehicle Owner's Manual for details.
- Pre-Collision Braking System is not turned off during TRACK mode.
⇒ Refer to the vehicle Owner's Manual for details.
- TRC system and Vehicle Stability Control (VSC) are not set to off.
⇒ Refer to the vehicle Owner's Manual for details.

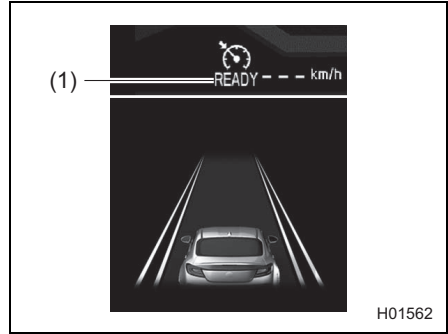

(1) READY indicator

MT models:

- Both the driver's door and the front passenger's door are closed.
- The driver's seatbelt is fastened.
- The shift lever is in a position from "2" to "6".
- The brake pedal is not depressed.
- The clutch pedal is not depressed.
- The road is not a steep slope.
- The steering wheel has not been turned significantly in either direction.
- The vehicle speed is between approximately 30 km/h and 145 km/h.
- Parking brake is released.
- Pre-Collision Braking System is not turned off during TRACK mode.
 - ⇒ Refer to the vehicle Owner's Manual for details.
- TRC system and Vehicle Stability Control (VSC) are not set to off.
 - ⇒ Refer to the vehicle Owner's Manual for details.

3. Control the accelerator pedal to reach the desired speed.

4. When the vehicle reaches the desired speed, push the cruise control switch to the “+ RES” side or the “- SET” side. The vehicle speed at the time the switch is pushed becomes the set vehicle speed, and constant speed driving will initiate.

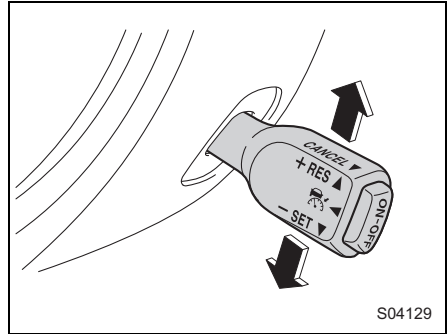

When Conventional Cruise Control is activated, **READY** (READY indicator) turns off, the set vehicle speed is displayed, and  (Conventional Cruise Control indicator) changes from white to green.

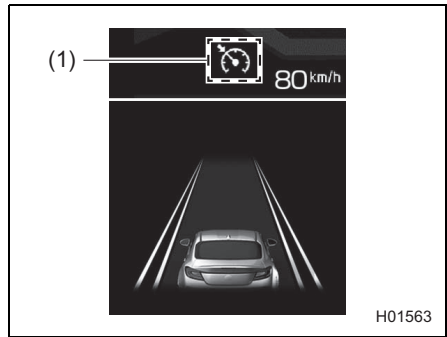

 **WARNING**

- The “Obstacle Detected” warning will not activate while Conventional Cruise Control is functioning.
- When using Conventional Cruise Control, always set the speed according to the speed limit, traffic flow, road conditions, and other conditions.

 **CAUTION**

During Conventional Cruise Control use, accelerator and brake control to follow the vehicle in front is not performed. Operate the accelerator and brake pedals as necessary.

**NOTE**

- On a downhill grade, automatic braking may operate in order to maintain the set vehicle speed.
- When driving on a curve, the vehicle may not accelerate, or may decelerate, even if the set vehicle speed is higher than the current vehicle speed.
- To return to Adaptive Cruise Control use, cancel Conventional Cruise Control and then briefly press the  (Following distance setting) switch. A notification sounds 1 short beep when switching to Adaptive Cruise Control.

■ Increasing the set vehicle speed

● Using the cruise control switch

- Push to the “+ RES” side briefly.
Every time the switch is pushed, the set vehicle speed will increase to the next 5 km/h increment.
- Push to the “+ RES” side continuously.
While the switch is being pushed, the set vehicle speed will increase in increments of 1 km/h.

When operating the switch, the set vehicle speed changes on the combination meter display.

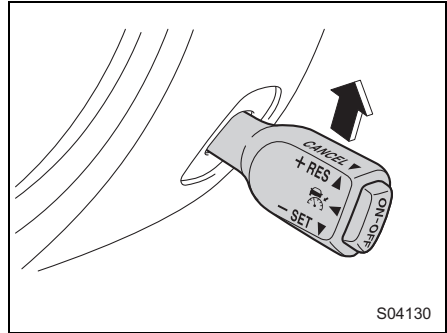

● Using the accelerator pedal

1. Depress the accelerator pedal to increase vehicle speed.

2. When the desired speed is reached, push the cruise control switch to the “- SET” side.

The speed at the time of pushing the switch will be set as the new set vehicle speed, and it appears on the combination meter display.

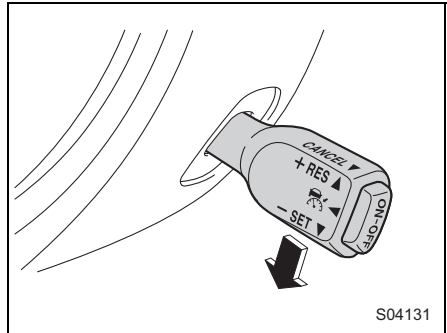

■ Decreasing the set vehicle speed

● Using the cruise control switch

- Push to the “- SET” side briefly.
Every time the switch is pushed, the set vehicle speed will decrease to the next 5 km/h decrement.
- Push to the “- SET” side continuously.
While the switch is being pushed, the set vehicle speed will decrease in decrements of 1 km/h.

When operating the switch, the set vehicle speed changes on the combination meter display.

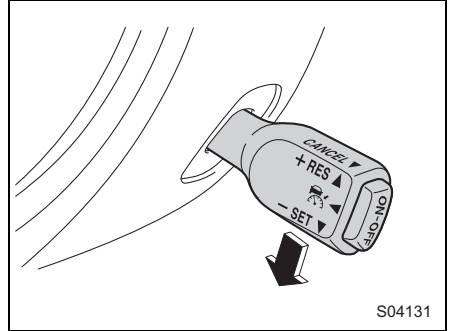

● Using the brake pedal

1. Depress the brake pedal to decrease the vehicle speed.
Conventional Cruise Control will be canceled and  (Conventional Cruise Control indicator) changes from green to white.
2. When the desired speed is reached, push the cruise control switch to the “- SET” side.
The speed at the time of pushing the switch will be set as the new set vehicle speed, and it appears on the combination meter display.

■ Accelerating temporarily

Depress the accelerator pedal to accelerate temporarily.

When the accelerator pedal is released, the vehicle returns to the set vehicle speed.

■ Decelerating temporarily

Depress the brake pedal to decelerate temporarily. When the brake pedal is depressed, Conventional Cruise Control will be canceled. While the set vehicle speed remains displayed on the combination meter display,  (Conventional Cruise Control indicator) changes from green to white.

Release the brake pedal and push the cruise control switch to the “+ RES” side to restore the set vehicle speed.

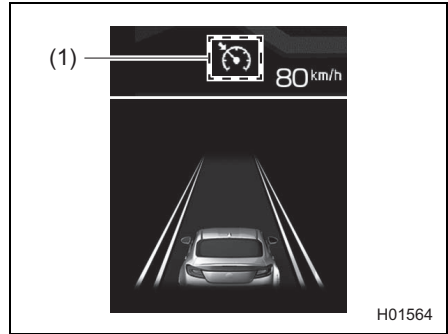

(1) White

■ Canceling Conventional Cruise Control

● Canceling by driver operation

Any of the following operations will cancel Conventional Cruise Control.

 (Conventional Cruise Control indicator) changes from green to white while the set vehicle speed remains displayed on the combination meter display.

- Depress the brake pedal.

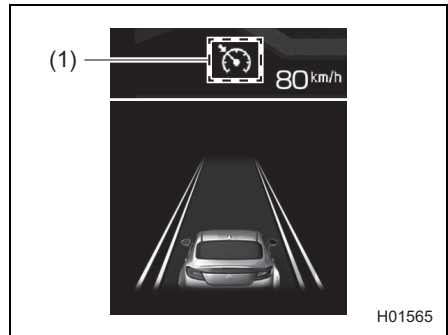

(1) White

- Pull the cruise control switch to the CANCEL side.

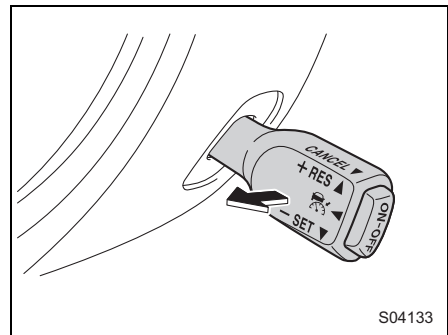

● Automatic cancellation by the system



WARNING

Do not use Conventional Cruise Control on slippery roads. Doing so may result in an accident.







CAUTION

- AT models: When the select lever is shifted to the “N” position, Conventional Cruise Control will be automatically canceled. Do not shift the select lever to the “N” position except in an emergency. Otherwise, the engine brake may not operate, which could cause an accident.
- MT models: If the shift lever is left in the neutral position for approximately 5 seconds or longer, Conventional Cruise Control will be automatically canceled. Do not leave the shift lever in the neutral position. Otherwise, engine braking will not be effective, which could cause an accident.



NOTE

- If EyeSight is malfunctioning,  (EyeSight warning indicator: Yellow) is displayed on the combination meter display, and  (Pre-Collision Braking System OFF indicator light) and  (Lane Departure Warning OFF indicator light) will also illuminate. If this occurs, stop the vehicle in a safe location and then turn off the engine and restart it. If the indicators remain illuminated after restarting the engine, Conventional Cruise Control cannot be used. This will not interfere with ordinary driving. However, contact a SUBARU dealer and have the system inspected.
⇒ Page 101
- When operation of Conventional Cruise Control has been automatically canceled, perform the set operation again after the condition that caused the cancellation has been resolved. If Conventional Cruise Control cannot be activated even after the condition has been corrected, EyeSight may be malfunctioning. This will not interfere with ordinary driving. However, contact a SUBARU dealer and have the system inspected.

Under the following conditions, a notification sounds 1 short beep and 1 long beep, and Conventional Cruise Control is automatically canceled.  (Conventional Cruise Control indicator) changes from green to white. Also, an interruption screen is displayed on the combination meter display.

AT models:

- The select lever is moved to a position other than “D” or “M”.
- Vehicle speed drops to approximately 25 km/h or less (due to a steep uphill grade or some other reason).
- Vehicle speed increases to approximately 160 km/h or more.
- TRC system or Vehicle Stability Control (VSC) is activated.
- Either the driver’s door or the front passenger’s door is opened.
- The driver’s seatbelt is unfastened.
- The EyeSight system has a malfunction.  (EyeSight warning indicator: Yellow)
⇒ Page 101
- The steering wheel is turned significantly in either direction.
- The grade of the road is very steep.
- The Pre-Collision secondary braking is activated.
- Parking brake is applied.
- The engine revolutions approached the red zone.
- The driving mode is set to snow mode.
⇒ Refer to the vehicle Owner’s Manual for details.
- Pre-Collision Braking System is turned off during TRACK mode.
⇒ Refer to the vehicle Owner’s Manual for details.
- TRC system and Vehicle Stability Control (VSC) are off.
⇒ Refer to the vehicle Owner’s Manual for details.
- The driving wheels spin on a slippery road.

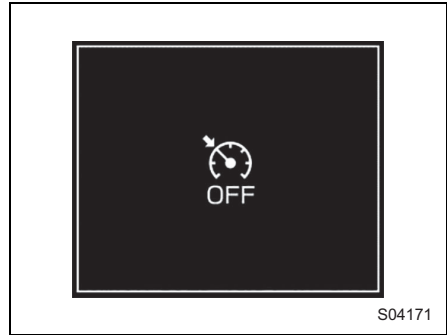

After the conditions have been resolved, perform the Conventional Cruise Control set operation again to reactivate Conventional Cruise Control.

MT models:

- The shift lever is in the “1” or “R” position, or the shift lever has been in the neutral position for approximately 5 seconds or longer.
- The clutch pedal is depressed for approximately 5 seconds or longer.
- Vehicle speed drops to approximately 25 km/h or less (due to a steep uphill grade or some other reason).
- Vehicle speed increases to approximately 160 km/h or more.
- TRC system or Vehicle Stability Control (VSC) is activated.
- Either the driver’s door or the front passenger’s door is opened.
- The driver’s seatbelt is unfastened.
- The EyeSight system has a malfunction.  (EyeSight warning indicator: Yellow)
⇒ Page 101
- The steering wheel is turned significantly in either direction.
- The grade of the road is very steep.
- The Pre-Collision secondary braking is activated.
- Parking brake is applied.
- The engine revolutions approached the red zone.
- Pre-Collision Braking System is turned off during TRACK mode.
⇒ Refer to the vehicle Owner’s Manual for details.
- TRC system and Vehicle Stability Control (VSC) are off.
⇒ Refer to the vehicle Owner’s Manual for details.
- The driving wheels spin on a slippery road.

After the conditions have been resolved, perform the Conventional Cruise Control set operation again to reactivate Conventional Cruise Control.

■ Restoring the previously set vehicle speed

The previously set vehicle speed is stored in memory. To restore that vehicle speed, push the cruise control switch to the “+ RES” side.  (Conventional Cruise Control indicator) changes from white to green.

You can restore the set vehicle speed when the previously set vehicle speed has been stored and the current vehicle speed is approximately 30 km/h or more.

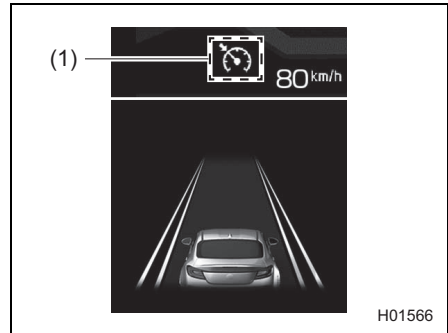
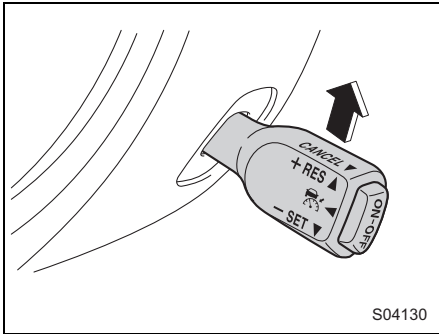

(1) Green



NOTE

- The vehicle speed stored in memory is erased in the following circumstances:
 - The cruise control is turned off by pressing the ON-OFF switch.
 - TRC system or Vehicle Stability Control (VSC) is activated.
 - The cruise control mode was switched from Conventional Cruise Control to Adaptive Cruise Control.
 - The vehicle drives constantly and correspondingly to the set vehicle speed between 30 km/h and 145 km/h.
 - If there is no vehicle speed stored in memory (previous vehicle speed), the current vehicle speed is set when the cruise control switch is pushed to the “+ RES” side.
- ⇒ Page 86

■ Turning off Conventional Cruise Control

Press the ON-OFF switch.

 (Conventional Cruise Control indicator) turns off on the combination meter display and Conventional Cruise Control turns off.

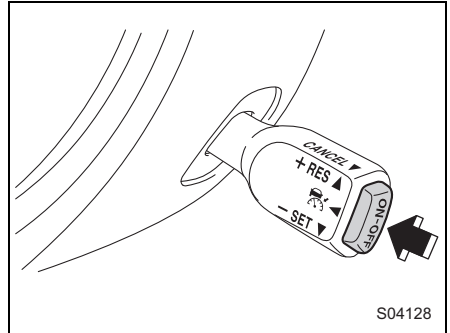

List of alert/notification sounds

Alert/notification sound	Status	Reference page
Single continuous beep	Pre-Collision Braking System: Secondary Braking is active.	⇒ Page 33
1 short beep and 1 long beep	Adaptive Cruise Control or Conventional Cruise Control is canceled automatically.	⇒ Pages 59 and 95
Repeated short beeps	Pre-Collision Braking System: First Braking is active.	⇒ Page 33
	Pre-Collision Braking System: The following distance warning is active.	
	The "Obstacle Detected" warning from Adaptive Cruise Control is active.	⇒ Page 65
	Pre-Collision Throttle Management is active. (AT models)	⇒ Page 67
3 short beeps	Lane Departure Warning is active.	⇒ Page 74
	Lane Sway Warning is active.	⇒ Page 78
3 intermittent beeps, 1 short beep and 1 long beep	Pre-Collision Braking System: Just before the automatic brake is slowly released by the system after the vehicle is stopped by the pre-collision braking.	⇒ Page 33
	Adaptive Cruise Control System: Just before the automatic brake is released by the system after the vehicle is stopped by Adaptive Cruise Control System. Adaptive Cruise Control System will stop the vehicle according to the lead vehicle stops. (AT models)	⇒ Page 59
1 short beep	Either of the following occurs while Adaptive Cruise Control is activated. - A vehicle in front is detected.* - A vehicle in front is no longer detected.*	⇒ Page 46
	The cruise control mode (Adaptive Cruise Control ↔ Conventional Cruise Control) is changed.	⇒ Page 86
	EyeSight is malfunctioning.	⇒ Page 101
	EyeSight operation is temporarily stopped.	⇒ Page 103
Two-tone beep	Lead Vehicle Start Alert is active.*	⇒ Page 82



*: The notification that indicates when a lead vehicle is detected or when it is no longer detected (Lead Vehicle Acquisition Sound), as well as Lead Vehicle Start Alert can be turned on or off.

⇒ Page 105

EyeSight malfunction and temporary stop

If a malfunction is detected in the EyeSight system, the indicators and interruption screens on the combination meter inform the driver of the malfunction. Check the displayed contents and take the appropriate action.

Malfunction (including position/angle misalignment of stereo camera)

The alert sounds 1 short beep, and  (EyeSight warning indicator: Yellow) illuminates or blinks. At the same time,  (Pre-Collision Braking System OFF indicator light) and  (Lane Departure Warning OFF indicator light) illuminate. An interruption screen is also displayed on the combination meter display.

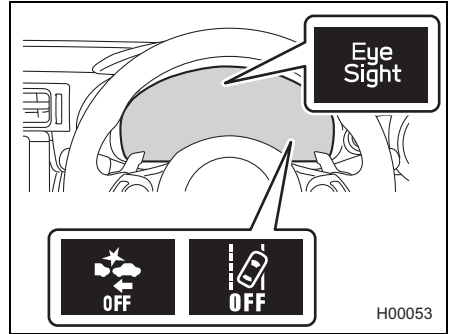

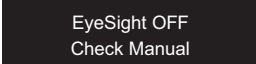
Displayed screen	Cause	Action
 H00014	An EyeSight malfunction or position/angle misalignment of the stereo camera has occurred.	Inspection and adjustment is necessary. Contact a SUBARU dealer.



CAUTION

If both  (EyeSight warning indicator: Yellow) and the CHECK ENGINE warning light/malfunction indicator light illuminate at the same time while driving, have your vehicle checked/repared by a SUBARU dealer as soon as possible. EyeSight cannot be used if there is an abnormality with the engine, etc.



⇒ Refer to the vehicle Owner's Manual for details.



NOTE

- If  (EyeSight warning indicator: Yellow) is illuminating or blinking, stop the vehicle in a safe location, turn off the engine and then restart it.
- If  (EyeSight warning indicator: Yellow) continues illuminating or blinking even after the engine has been restarted, the EyeSight system has a malfunction. In this case, all EyeSight functions will be stopped. Normal driving will still be possible. However, contact a SUBARU dealer for an inspection.
- If  (EyeSight warning indicator: Yellow) illuminates or blinks, the Reverse Automatic Braking (RAB) system will not operate. (AT models)



Temporary stop

The alert sounds 1 short beep, and  (EyeSight temporary stop indicator: White),  (Pre-Collision Braking System OFF indicator light) and  (Lane Departure Warning OFF indicator light) illuminate at the same time. An interruption screen is also displayed on the combination meter display.

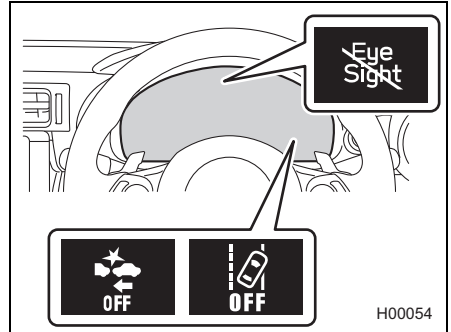
When the cause has been resolved, temporary stop will be canceled and the EyeSight system will automatically restart.



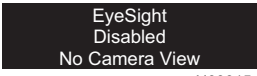

H00054

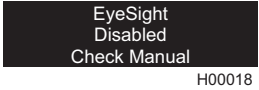
Displayed screen	Cause	Action
 H00015	It is difficult for the stereo camera to detect objects in front. <ul style="list-style-type: none"> • The windshield is dirty or fogged up. • Poor weather conditions • Strong light from the front 	<ul style="list-style-type: none"> • Clean the windshield. • In poor weather conditions or if there is strong light from the front, the EyeSight system will restart once you have driven your vehicle for a period of time and the conditions affecting the system have improved. If the system does not restart, even after the conditions have improved and a period of time has elapsed, contact a SUBARU dealer for an inspection.
 H00017	In low or high temperatures	The system will restart once the temperature is within the operational range of the EyeSight system. If the system does not restart, even when the temperature inside the vehicle is within the operational range, contact a SUBARU dealer for an inspection.

Displayed screen	Cause	Action
 <p>EyeSight Disabled Check Manual H00018</p>	<ul style="list-style-type: none"> • The EyeSight system is starting up. • The system has determined that the vehicle is extremely inclined. • The Pre-Collision secondary braking has operated 3 times after the engine was started. • The engine has stopped. (AT models) 	<p>The system will restart once the cause has been resolved. At this time, it may take some time for the system to restart.</p> <p>If the system does not restart, even after the conditions have improved and a period of time has elapsed, contact a SUBARU dealer for an inspection.</p>

 **NOTE**

- When  (EyeSight temporary stop indicator: White) is illuminated, none of the EyeSight functions can be used except for Conventional Cruise Control.
- When  (EyeSight temporary stop indicator: White) is illuminated, the Reverse Automatic Braking (RAB) system may not operate. (AT models)

Changing settings

The following settings can be changed on the center information display or combination meter display.

Center information display



- (1) Car settings icon
(2) Settings icon

1. →  (Settings)
2. → "Car"
3. Select the preferred menu.

	Item	Setting
EyeSight	Pre-Collision Braking	Setting ON/Setting OFF
	Lane Departure Warning	ON/OFF
	Cruise Control Acceleration Characteristics	Lv.1 (Eco)/ Lv.2 (Comfort)/ Lv.3 (Standard)/ Lv.4 (Dynamic)
	Lead Vehicle Acquisition Sound	ON/OFF
	Lead Vehicle Moving Monitor	ON/OFF
	Select Drive on Left/Drive on Right	Right Lane/Left Lane
Warning Volume		Min/Mid/Max

Touch  (Car settings icon) to display the items that are changeable while driving. Change the EyeSight system setting as follows:

1. Touch  (Car settings icon).
2. Select the preferred menu.



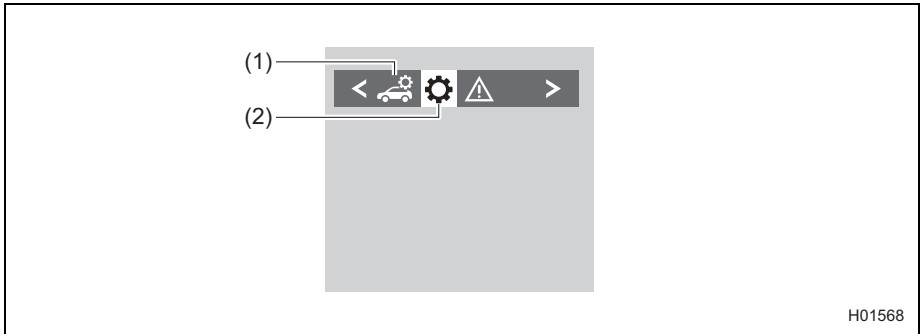

	Item	Setting
Vehicle Control	Cruise Control Acceleration Characteristics	Lv.1 (Eco)/ Lv.2 (Comfort)/ Lv.3 (Standard)/ Lv.4 (Dynamic)
Driving Assistance	Pre-Collision Braking	Setting ON/Setting OFF
	Lane Departure Warning	ON/OFF
Others	Warning Volume	Min/Mid/Max

Combination meter display



H01568

- (1) Driver Assist icon
(2) Settings icon

1. Press the < / > of the meter operation switch to select  or .
2. Press  /  to select the setting that you want to change.
3. Press the  switch.

Item		Setting	
Driver Assist	LDW (Lane Departure Warning)	ON/OFF	
	PCB (Pre-Collision Braking System)	ON/OFF	
Settings	EyeSight	Acquisition Sound (Lead Vehicle Acquisition Sound)	ON/OFF
		Start Alert (Lead Vehicle Moving Monitor)	ON/OFF
		Accel Lv. (Cruise Control Acceleration Characteristics)	Lv.1 (Eco)/ Lv.2 (Comfort)/ Lv.3 (Standard)/ Lv.4 (Dynamic)
		Select Drive Lane (Select Drive on Left/Drive on Right)	Right Lane/Left Lane
	Warning Volume	Min/Mid/Max	

Items that can be set

● Pre-Collision Braking System (PCB)

Pre-Collision Braking System and Pre-Collision Throttle Management (AT models) can be activated or deactivated.

● Lane Departure Warning (LDW)

Lane Departure Warning and Lane Sway Warning can be activated or deactivated.

● Cruise Control Acceleration Characteristics (Accel Lv.)

The Cruise Control Acceleration Characteristics of the Adaptive Cruise Control and Conventional Cruise Control system can be set to one of four levels.

Lv.1 (Eco): Mode that focuses on driving with smooth movement and optimum fuel economy.

Lv.2 (Comfort): Mode that focuses on driving with smooth movement.

Lv.3 (Standard): Mode that focuses on quick response acceleration.

Lv.4 (Dynamic): Mode used when powerful acceleration is required.

● Lead Vehicle Acquisition Sound (Acquisition Sound)

The Lead Vehicle Acquisition Sound setting can be activated or deactivated.

● Lead Vehicle Moving Monitor (Start Alert)

The Lead Vehicle Start Alert function setting can be activated or deactivated.

● Select Drive on Left/Drive on Right (Select Drive Lane)

It is possible to switch between driving on the left-hand side of the road and driving on the right-hand side.

The Adaptive Cruise Control (⇒ page 39) function is adapted to the set traffic lane direction.



WARNING

If the Select Drive Lane setting does not match the flow of traffic, full EyeSight performance may not be available.

● Warning Volume

The volume can be set to Min/Mid/Max.

Message screen list



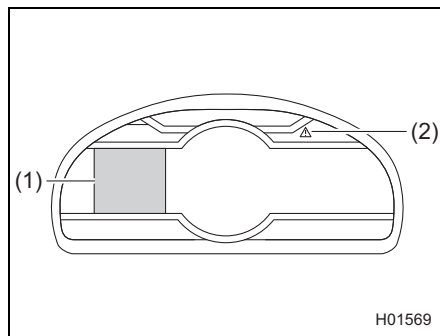

If an EyeSight warning or malfunction is detected, a message will be displayed on the meter information screen and the master warning light will illuminate on the combination meter. Depending on the message, an alert/notification sounds at the same time.

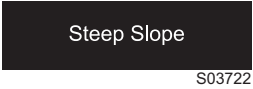

- (1) Meter information screen
- (2) Master warning light

If a message is displayed, refer to the message list and take the appropriate action.

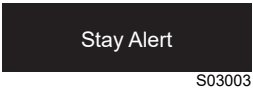
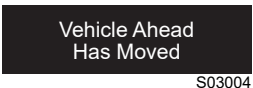







Message screen list (precautions and notices)











Displayed screen	Item	▲ mark	Reference page
 <p>S02999</p>	Pre-Collision Braking System	None	⇒ Page 33
	The “Obstacle Detected” warning	None	⇒ Page 65
	Pre-Collision Throttle Management (AT models)	None	⇒ Page 67
 <p>S03722</p>	Adaptive Cruise Control/Conventional Cruise Control automatic cancellation (when the grade of the road is very steep)	None	⇒ Pages 59 and 95
 <p>S03002</p>	Lane Departure Warning	None	⇒ Page 74
 <p>S03003</p>	Lane Sway Warning	None	⇒ Page 78
 <p>S03004</p>	Lead Vehicle Start Alert	None	⇒ Page 82
 <p>203196</p>	EyeSight system automatic cancellation	None	⇒ Page 59
 <p>H00002</p>		None	⇒ Page 95









Message screen list (malfunction, temporary stop)



Displayed screen	Item	⚠ mark	Reference page
<p>EyeSight OFF Check Manual</p> <p>H00014</p>	EyeSight system malfunction	Yes	⇒ Page 101
<p>EyeSight Disabled No Camera View</p> <p>H00015</p>	EyeSight system temporary stop	None	⇒ Page 103
<p>EyeSight Disabled Temp Range</p> <p>H00017</p>		None	
<p>EyeSight Disabled Check Manual</p> <p>H00018</p>		None	



Troubleshooting



	Adaptive Cruise Control cannot be activated.
	Did you remember to press the ON-OFF switch? If you have not pressed the ON-OFF switch,  (Adaptive Cruise Control indicator) will not be shown.
	Is EyeSight operation temporarily stopped? When EyeSight is temporarily stopped,  (EyeSight temporary stop indicator: White) is displayed on the combination meter display. Set Adaptive Cruise Control again after the cause for the temporary stop has been corrected.
	Is READY (READY indicator) displayed? Adaptive Cruise Control cannot be activated when READY (READY indicator) is not displayed. Set Adaptive Cruise Control when READY (READY indicator) is displayed.
	READY (READY indicator) is not displayed.
	Are the requirements for setting the function met? For the conditions of READY (READY indicator) illumination, refer to the following pages. ⇒ Page 46 (Adaptive Cruise Control) ⇒ Page 86 (Conventional Cruise Control)



	<p>A vehicle (in front of your vehicle) is not detected, detection is delayed or detection is lost quickly.</p>
	<p>Is the vehicle in front stopped, moving slowly relative to your vehicle or moving extremely slowly? Detection of stopped vehicles, vehicle moving slowly relative to your vehicle, and vehicles moving extremely slowly may be difficult.</p>
	<p>Is the windshield dirty or fogged? If the windshield is dirty or fogged, it may not be possible to detect object or vehicles. Clean off the dirt or fog from the windshield, and then try using the system again.</p>
	<p>Is the vehicle in front far away? The maximum detection distance of the stereo camera is approximately 110 m. Detection is not possible if the vehicle is farther away.</p>
	<p>Is the vehicle on a curve? The detection range is limited in the horizontal directions when the stereo camera is properly aimed.</p>
	<p>Is the vehicle on a road with repeated uphill and downhill grades (such as an overpass), or on a banked road? The detection range is limited in the vertical directions.</p>
	<p>Did the vehicle detected in front change? Detection may be delayed after the vehicle in front has changed.</p>
	<p>Have water, snow or other substances been kicked up by the vehicle in front as it drives? When water or snow have been kicked up, it may not be possible to detect the vehicle in front.</p>
	<p>While Adaptive Cruise Control is active, brake control is operated even though no vehicle in front has been detected.</p>
	<p>Is there a vehicle in the neighboring lane? Depending on the road conditions, vehicles in neighboring lanes may be detected as well as a vehicle directly in front.</p>
	<p>Are you driving on or near a curve? When driving on a curve, braking control may be activated in response to guardrails, the angle of the steering wheel, or roadside structures.</p>

	<p>Lead Vehicle Start Alert activates, even though there is no vehicle in front.</p>
	<p>Depending on surrounding objects, traffic environment and weather, Lead Vehicle Start Alert may issue a warning in response to objects other than a vehicle that appears in front of your vehicle.</p>
	<p>EyeSight does not restart after a temporary stop.</p>
	<p>Are you driving in the rain with poorly performing wipers or is there a smear on the windshield? Replace the wipers with new ones, or clean the smear off the windshield. Are you driving in poor weather conditions with heavy rain, snow, fog, or dust? In these cases, EyeSight may temporarily stop operating while visibility is very poor.</p>
	<p>Is your vehicle subject to sunlight from the front (sunset or sunrise, etc.) or to bright headlights from oncoming vehicles at nighttime? In these cases, EyeSight may temporarily stop operating.</p>
	<p>Are you parking in an extremely hot or cold condition? In either of these cases, EyeSight may temporarily stop operating until the temperature increases or decreases to a temperature at which the camera is operable.</p>
	<p>Is the windshield dirty or fogged? If the windshield is dirty or fogged, clean off the dirt or fog from the windshield, and then try using the system again.</p>
	<p>The timing of the “Obstacle Detected” warning is sometimes earlier or sometimes later than what seems to be normal operation.</p>
	<p>The “Obstacle Detected” warning sounds when the system determines that more braking is necessary, based on conditions such as the distance from the vehicle in front and the difference in speed compared to it. As a result, timing may vary depending on how the brakes are applied in relation to the vehicle in front, and your relative speed to that vehicle.</p>

	<p>When the vehicle in front has turned off the roadway or the distance from the vehicle in front has increased, acceleration is sometimes slower or faster.</p>
	<p>Depending on the timing of when the detection of the vehicle in front is lost, EyeSight's ability to react may be slower, causing the start of acceleration to feel delayed and braking time to feel longer than what seems to be normal operation.</p>
	<p>What acceleration level did you select for cruise control*? Acceleration may vary because the cruise control characteristics vary depending on the selected mode. *: Adaptive Cruise Control and Conventional Cruise Control</p>

	<p>Cruise control is canceled automatically.</p>
	<p>Did you perform one of the following operations? ⇒ Page 58 (Adaptive Cruise Control) ⇒ Page 94 (Conventional Cruise Control)</p>
	<p>Has the EyeSight system temporarily stopped while the Adaptive Cruise Control function was in use?</p>

	<p>A noise occurs when automatic braking control activates.</p>
	<p>This is the sound of the automatic braking control operating - there are some mechanical components to the system, and they do occasionally make audible sounds during automatic braking control. This does not indicate a malfunction.</p>

	<p>Braking control activates frequently when driving with Adaptive Cruise Control in heavy traffic.</p>
	<p>When Adaptive Cruise Control is activated, the EyeSight system performs control based on the movement of vehicles or objects in front. As a result, acceleration and deceleration may be more frequent while the system adjusts to vehicles or objects the camera system is detecting. If it is difficult to maintain a consistent following distance under certain conditions (such as in heavy traffic, poor weather or urban environments, etc.), do not use Adaptive Cruise Control.</p>

MEMO